



13.  
*year*



2024



**THETFORD**

**truma**

**THULE**  
SWEDEN

**ABL**

**Alde**

**baldacci**

**COMET**  
SMART • EQUIPMENT • SOLUTIONS

**euramax**  
FOR MOBILITY

**HABA**

**HARTAL**

**JARUP**

**jokon**  
Competence in Lighting

**LIPPERT**

**mpk**

**NOBILPAN**  
Finishing panels

**RENOGY**

**STS**  
Oberholz

**WESTACC**  
group



# CONTENTS

---



## AWNINGS

AWNINGS	4
SMART PANELS	22
TENTS	26



## DOORS AND WINDOWS

CARAVAN WINDOWS	30
CARAVAN DOORS	34



## ROOF VENTS

ROOF VENTS	38
------------	----



## WINDOW BLIND - FLYSCREEN

WINDOW BLIND - FLYSCREEN	44
--------------------------	----



## SERVICE DOORS

SERVICE DOORS	46
---------------	----



## KITCHEN

REFRIGERATORS	48
OVENS	58
COOKERS	62
COMBINATION COOKERS	68
SINKS	72
FAUCETS	74



## BATHROOM - TOILET

TOILET CARE	78
CASSETTE TOILETS	84
PORTABLE TOILETS	88
TAPS	90
SINKS	94
TOILET FANS	95



## WATER SYSTEMS

WATER SYSTEMS	96
---------------	----



## WATER TANKS

CLEAN WATER TANKS	100
WASTE WATER TANKS	103



## COOLING SYSTEMS

ROOF-MOUNTED AIR CONDITIONERS	104
FLOOR TYPE AIR CONDITIONER	112



## HEATING SYSTEMS

COMBI HEATERS	114
CENTRAL HEATING SYSTEM	122
CARAVAN HEATERS	130
WATER HEATERS	137



## GAS SYSTEMS

GAS MEASUREMENT DEVICES	142
GAS PRESSURE REGULATORS	144
GAS VALVES AND HOSES	148

# CONTENTS



## MANEVOURING SYSTEMS

MANEVOURING SYSTEMS 150



## BIKE RACKS

BIKE RACKS 154  
ACCESSORIES 162



## LADDERS

LADDERS 164



## ELECTRICAL - ENERGY SYSTEMS

SOLAR SYSTEM 169  
CONTROL PANELS 170  
BATTERIES 172  
INVERTERS 174  
IOT MONITORING 175  
BATTERY CHARGER AND  
CHARGE CONTROLLERS 176  
PORTABLE POWER STATIONS 181  
CONNECTION CABLES 183



## SOCKET INLET AND COVERS

SOCKET INLET AND COVERS 184



## SECURITY SYSTEMS

SECURITY SYSTEMS 188



## FURNITURE AND LOCKING SYSTEMS

FURNITURE AND LOCKING SYSTEMS 192  
TABLE LEGS 200  
BEDS 201  
FURNISHINGS 202



## CHASSIS SYSTEMS

CHASSIS SYSTEMS 205  
ALUMINUM PANELS 212



## LIGHTING SYSTEMS

MULTIFUNCTIONAL LIGHTS 214  
REAR LIGHTS 220  
MARKER LIGHTS 223  
NUMBER PLATE LIGHTS 225  
STOP LIGHTS 226  
REFLECTORS 229  
AMBIENT LIGHTS 231



## CAMPING AND CARAVAN ACCESSORIES

ROOFTOP TENTS 241  
CAMPING AND CARAVAN ACCESSORIES 246

# AWNINGS

---

- AWNINGS
- SUN BLOCKER
- RAIN BLOCKER
- VIEW BLOCKER
- WIND BLOCKER
- TENTS



Thule Omnistor awnings have a perfect design where visibility and functionality meet. Thule Omnistor offers awnings in 3 different categories to suit your vehicle and personal needs.



#### Wall Mount Awnings

- The most convenient and common installation on the vehicle wall
- Manufactured to fit all vehicle types.  
A wide range of adapters are available developed and approved by caravan manufacturers.
- It can be easily mounted on the awning rail of caravans.
- If there is enough mounting space between the top of your vehicle's door and the ceiling, you can use wall mount awnings.
- Thule 3200, 4200, 5200 and 8000 series awnings are in the wall mount awning category.



#### Roof Awnings

- Installation on caravan roof
- Selection of adapters for all caravan manufacturers' models and the most leading caravan manufacturers
- Perfect integrated system for all caravan manufacturers
- If there is not enough mounting space between the top of your vehicle's door and the ceiling, you can use ceiling mounting awnings.
- Thule 6300 and 9200 series awnings are in the ceiling mount awning category.



#### Bag Awnings

- Rail installation that does not require brackets:  
It is suitable for the rail system of all vehicles.
- Much lighter than its competitors thanks to the special products used
- Thule 1200 series awnings are in the bag awning category.

**THULE** Omnistor







**Thule Omnistor 5200**



**Thule Omnistor 8000**



**Thule 4200**



**Thule 3200**

<b>Motorhome</b>				
<b>Caravan</b>				
<b>Van</b>				
<b>Length</b>	1.92 - 5.02m	4.00 - 6.00m	2.60 - 4.50m	2.50m
<b>Projection</b>	1.40 - 2.50m	2.75m	2.00 - 2.50m	1.90 - 3.00m
<b>Weight</b>	14.20 - 32.80kg	41.40 - 55.40kg	17.50 - 29.00kg	15.60kg
<b>Power</b>	12 VDC	220 VAC		
<b>Cassette color</b>	Gray White Black	Gray White Cream	Gray White Black	Light grey Black



**Thule Omnistor 9200**



**Thule Omnistor 6300**

<b>Motorhome</b>		
<b>Caravan</b>		
<b>Van</b>		
<b>Length</b>	4.00 - 6.00m	2.60 - 5.00m
<b>Projection</b>	3.00m	2.00 - 2.50m
<b>Weight</b>	42.40 - 57.60kg	17.60 - 36.60kg
<b>Power</b>	220 VAC	
<b>Cassette color</b>	Gray White Cream	Gray White Black



**Ease of use**

Manual awnings have a telescopic hand crank for opening and motorised awnings have a remote control or a switch for effortless opening. Thanks to the Thule Quick Release system, the support legs can be released on demand to prevent them from falling during the set-up. All support legs are dropped vertically to reduce the risk of damaging your vehicle. Easily adjust the legs to the right heights with the user-friendly Thule Quick Lock system.



**Wide range of accessories**

Thule offers different accessories to extend your awning to suit your lifestyle. For example the Thule Smart Panels are the perfect solution if you want to create privacy and in the meantime be protected from weather elements such as sun, rain and wind. Add more outdoor living space by using Thule awning tent.



**Superior product stability**

Thule Omnistor awnings are equipped with sturdy tension arms in combination with an innovative support of the roller tube to create a perfectly tensioned awning fabric. They also increase resistance to wind for safer usage. Depending on the awning type, lengths from 3.75 m and more are supplied as standard with an integrated tensioning system or with an extra tension rafter to keep the fabric even tighter. All our awnings are tested in various weather conditions for optimal stability.



**Preferred awning brand**

Thule is the elected best brand in awnings for years. Thule has a large range of installation brackets and adapters available, developed together with and approved by the recreational vehicles manufacturers.



**Appealing design**

Thule Omnistor awnings have a timeless design that perfectly matches any vehicle type. Depending on your awning type, you have the choice between following cassette finishes: anodised, white, anthracite or anodised/black.



**Cassette finishes**

All Thule Omnistor awnings are made of sturdy aluminium profiles that guarantee long lasting safety and reliability. Thule awnings are tested under the toughest conditions to ensure they surpass current standards.**Fabric**



Gray



Black



White



Cream

**NOTE:** Not all cassette and fabric finishes can be combined. Please refer to each awning type to find out the available combinations.

**Fabric finishes**

The top quality PVC fabric is printed on both sides and has a coating to keep the fabric colour fixed, watertight, washable and durable. Depending on your awning type, you can choose different patterns for your awning fabric.



31 - Mystic Grey



32 - Sapphire Blue



04 - Wavy Gray



03 - Wavy Blue



22 - Uni Gray

**NOTE:** Uni White (22) is available on request with a longer delivery time.

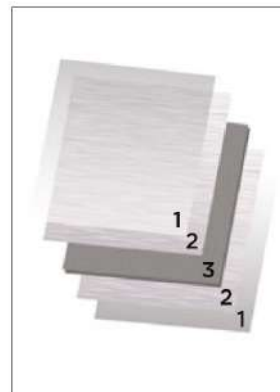

**FABRIC UV PROTECTION**

The coating not only ensures a high degree of scratch and fade-resistance, but also increases UV and heat-resistance.

**Long lasting reliability**

Top quality PVC fabric composed of 5 layers to ensure the awning is watertight, washable, durable and resistant to scratches.

- 1 - PVC top coat: ensures colour protection and scratch resistance
- 2 - Vinyl with printed pattern
- 3 - Strong layer in polyester scrim

### Manual roll-up box awning for compact vehicles

The Thule 3200 awning is available in 5 lengths from 1.90 m to 3.00 m with a projection of 2.50 m.

The awning cassette is available in completely anthracite finish or anodised with anthracite bottom and black end caps.

### Mounting

Ideal for direct mount on selected range of compact vans and roof rack installation on cars.

The awning brackets need to be bought separately.

### One-person operation

The awning can be set up by only one person. Open the cassette and take out the tension arms.

Roll out the awning manually and set up the support legs. At last, connect the tension arms with the support legs and create tension with the patented pump-buckle technology.

### Large projection

All awning lengths have a projection of 2.50 m, the largest projection on the market within its category.



Thule 3200 manual



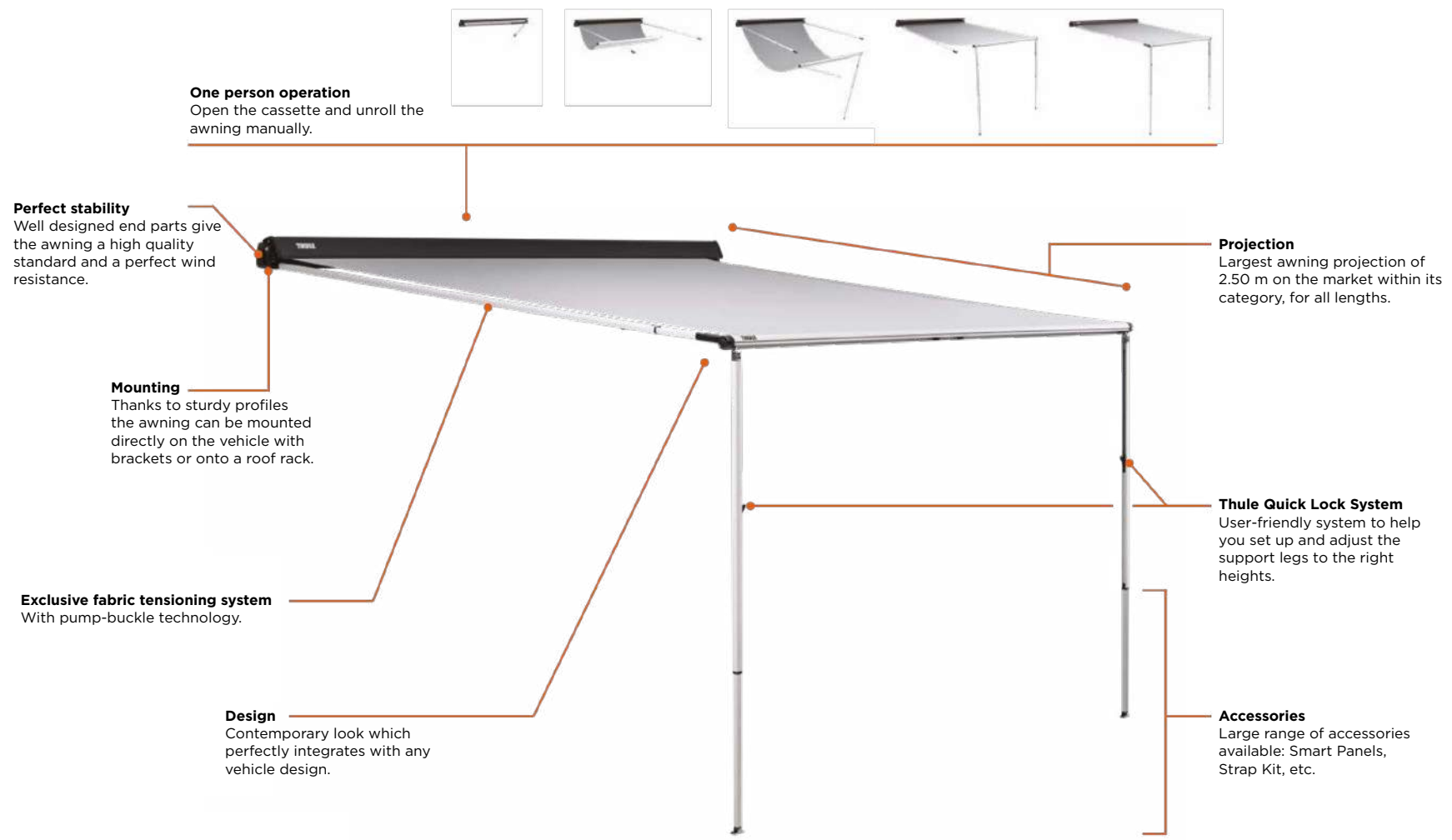

**One person operation**  
Open the cassette and unroll the awning manually.

**Perfect stability**  
Well designed end parts give the awning a high quality standard and a perfect wind resistance.

**Mounting**  
Thanks to sturdy profiles the awning can be mounted directly on the vehicle with brackets or onto a roof rack.

**Exclusive fabric tensioning system**  
With pump-buckle technology.

**Design**  
Contemporary look which perfectly integrates with any vehicle design.

**Projection**  
Largest awning projection of 2.50 m on the market within its category, for all lengths.

**Thule Quick Lock System**  
User-friendly system to help you set up and adjust the support legs to the right heights.

**Accessories**  
Large range of accessories available: Smart Panels, Strap Kit, etc.

Length	Projection	Weight
1.90 m	2.50 m	12.00 kg
2.30 m		13.80 kg
2.50 m		14.70 kg
2.70 m		15.60 kg
3.00 m		16.90 kg

**Cassette Finishes**

- Anthracite
- Anodised/Black



**New wall-mounted awning for your compact van**

The Thule 4200 awning is the lightest box awning in the market. It's available in lengths from 2.60 m to 3.00 m with a projection of 2.00 m to 2.50 m.

**Design**

Sleek design to obtain the best integration on the compact van through a new end cap shape. The awning cassette is available in white, anodised or anthracite and is combined with the Mystic Grey fabric.

**Optimal closing**

An easy roller tube adjustment system on the side opposite to the gear assures a perfect closing of the cassette, even after years of usage.

**Ease of use**

A telescopic hand crank ensures an easy opening and closing of the awning. Thanks to an especially designed and easy to apply sealing rubber with integrated drainage system, the gap between



Sleek design to obtain the best integration on the compact van through a new end cap shape

Thule 4200 manual





**Sealing rubber**  
Ensures that the gap between the vehicle and the wall awning is sealed.

**Patented roller tube support system**  
The roller tube support improves the fabric tension and reduces the chance of wrinkles in the fabric.

**Optional tension rafter**  
The updated Tension Rafter is easy to install, ensures an optimal fabric tension and improves the wind resistance of the awning.

**Smart innovation system**  
Support legs are released vertically from the lead rail to reduce the risk of damaging the vehicle.

**Anti-rattling system**  
The anti-rattling system supports the spring and support arms in closed position to reduce rattling noise while driving.

**Clamping force**  
Best clamping force of the support arms on the market in order to withstand the higher loads when mounting panels, tents and hold down kits.

**Improved storage**  
The support arms are held into place to make sure they do not fall out of the lead rail when opening the awning.

Length	Projection	Weight
2.60 m	2.50 m	17.50 kg
3.00 m		19.70 kg
3.50 m		21.70 kg
4.00 m		25.80 kg
4.50 m		29.00 kg

**Cassette Finishes**

- Anodized
- White
- Anthracite



\*When choosing fabric, please consult your Termosa sales consultant.

**Perfect fit wall awning for your van with lift roof**

For Fiat Ducato, Peugeot Boxer and Citroen Jumper > 2007 with lift roof, the wall-mounted awning Thule Omnistor 5200 is available with an especially designed adapter with integrated LED. Lengths: 3.15 m, 3.75 m and 4.00 m. For other brands, the Thule Omnistor 5200 awning is available in lengths from 1.90 to 5.00 m

**Operated manually or with a motor**

An optional 12 VDC motor with manual override allows you to operate awning lengths from 3.00 m and more without any effort. The motor can easily be installed retrofit as an accessory on a manual Thule Omnistor 5200 awning (+ 1 kg).

**Perfect fabric tension**

Sturdy spring arms with patented integrated tension arms ensure a perfectly tensioned awning fabric for increased wind resistance. The patented tension arms are standard integrated for awning lengths from 3.75 m and more and are optional for a 3.15 m awning length.



**Thule Omnistor 5200 - Manual**



**Thule Omnistor 5200 - Motorised**



**Add to your Thule Omnistor 5200**

**Smart Paneller**

- Thule Sun Blocker G2
- Thule Rain Blocker G2
- Thule View Blocker G2
- Thule Wind Blocker G2

**Tents**

- Thule Panorama
- Thule Residence G3
- Thule QuickFit

**Accessories**

- Thule Tent LED Rail Mounting Set 5200
- Thule LED Strip
- Thule 3rd Support Leg
- Thule 5200 Clamping Arm
- Thule Tensioner Swing G2
- Thule Retention Strap Side Hanger Set
- Thule Engine Set for 5200





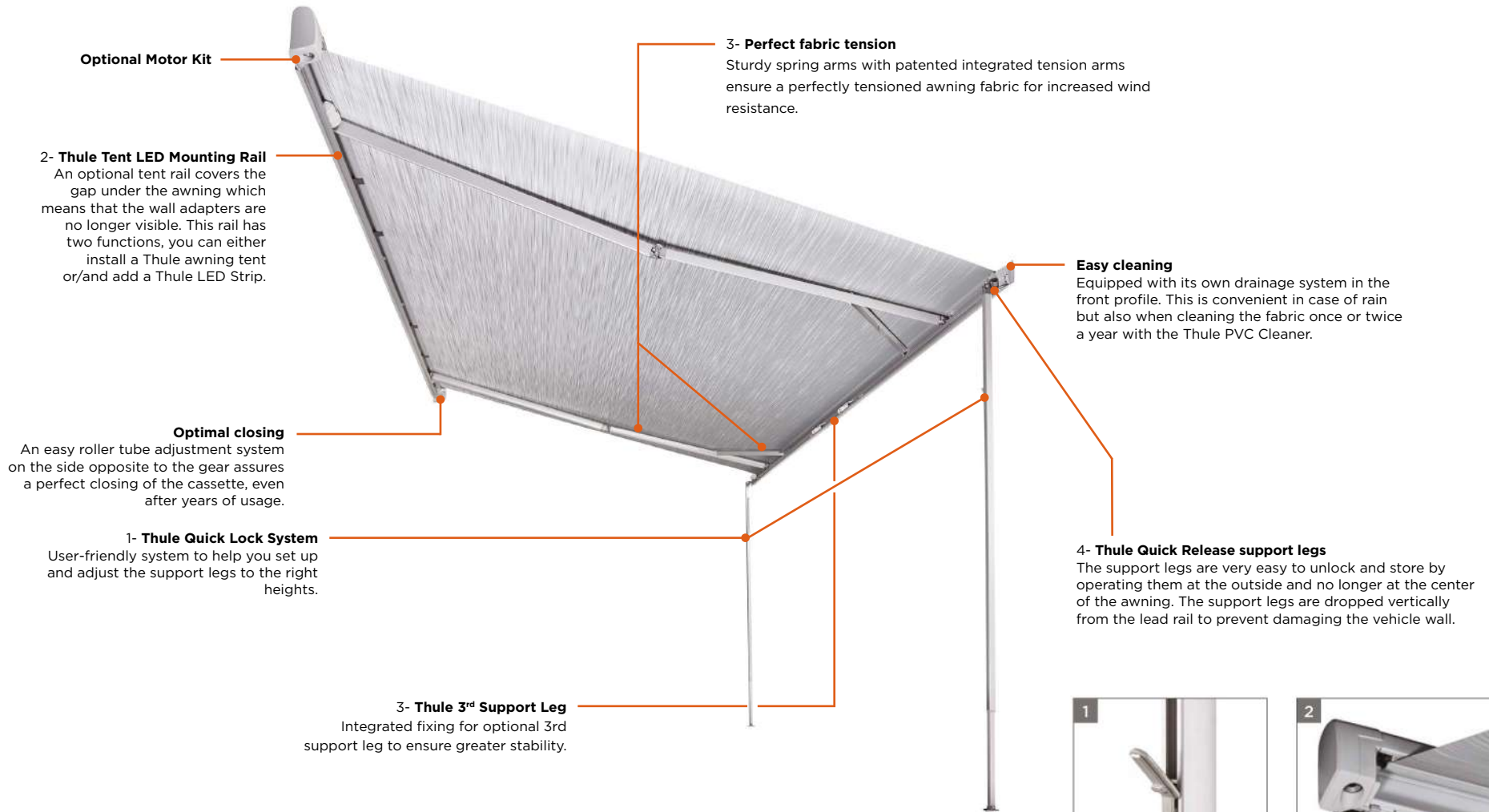

**Optional Motor Kit**

**2- Thule Tent LED Mounting Rail**

An optional tent rail covers the gap under the awning which means that the wall adapters are no longer visible. This rail has two functions, you can either install a Thule awning tent or/and add a Thule LED Strip.

**3- Perfect fabric tension**

Sturdy spring arms with patented integrated tension arms ensure a perfectly tensioned awning fabric for increased wind resistance.

**Easy cleaning**

Equipped with its own drainage system in the front profile. This is convenient in case of rain but also when cleaning the fabric once or twice a year with the Thule PVC Cleaner.

**Optimal closing**

An easy roller tube adjustment system on the side opposite to the gear assures a perfect closing of the cassette, even after years of usage.

**1- Thule Quick Lock System**

User-friendly system to help you set up and adjust the support legs to the right heights.

**4- Thule Quick Release support legs**

The support legs are very easy to unlock and store by operating them at the outside and no longer at the center of the awning. The support legs are dropped vertically from the lead rail to prevent damaging the vehicle wall.

**3- Thule 3<sup>rd</sup> Support Leg**

Integrated fixing for optional 3rd support leg to ensure greater stability.



**Cassette Finishes Fabric Color**

	Anodized		31*		03*
	White		32*		04*
	Anthracite		22*		

Length	Projection	Weight
1.92 m	1.40 m	14.20 kg
2.32 m	1.80 m	17.00 kg
2.62 m	2.00 m	19.00 kg
3.02 m	2.50 m	22.60 kg
3.52 m		25.40 kg
4.02 m		28.00 kg
4.52 m		30.40 kg
5.02 m	2.50 m	32.80 kg

\*When choosing fabric, please consult your Termosa sales consultant.

NOTE - When it rains, put down a support leg so the water can drain away easily.

### The perfect roof awning for vans

The Thule Omnistor 6300 awning is available in 3 lengths perfect for vans: 3.25 m, 3.75 m and 4.00 m with a projection of 2.50 m. The awning cassette is available in anodised, white, anthracite and in the colour combination anodised/black.

### Operated manually or with a motor

An optional 12 VDC motor with manual override allows you to operate awning lengths from 3.00 m and more without any effort. The motor can easily be installed as an accessory on a manual Thule Omnistor 6300 awning (+ 1 kg).

### Perfect fabric tension

Sturdy spring arms with patented integrated tension arms ensure a perfectly tensioned awning fabric for increased wind resistance. The patented tension arms are standard integrated for awning lengths 3.75 m and 4.00 m and are optional for a 3.25 m awning length.



Thule Omnistor 6300



### Add to your Thule Omnistor 6200

#### Smart Panels

- Thule Sun Blocker G2
- Thule Rain Blocker G2
- Thule View Blocker G2
- Thule Wind Blocker G2

#### Tents

- Thule Panorama
- Thule Residence G3
- Thule QuickFit

#### Accessories

- Thule LED Strip
- Thule Tent LED Mounting Bar
- Thule Retention Strap Side Hanger Set
- Thule Tensioner Swing G2
- Thule Engine Kit 6300





Length	Projection	Weight
2.60 m	2.00 m	19.60 kg
3.00 m	2.50 m	23.00 kg
3.25 m		24.00 kg
3.50 m		25.40 kg
3.75 m		27.00 kg
4.00 m		29.00 kg
4.25 m	2.50 m	30.20 kg
4.50 m		31.40 kg
5.00 m		35.60 kg

<b>Cassette Finishes</b>	<b>Fabric Color</b>
Anodized	31*  03*
White	32*  04*
Anthracite	22*

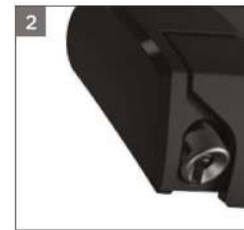
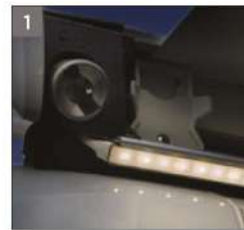

\*When choosing fabric, please consult your Termosa sales consultant.

NOTE - When it rains, put down a support leg so the water can drain away easily.





**2 - Design**  
Contemporary look which perfectly integrates with any vehicle design  
Improved masking and finish of the technical parts.

**1 - Easy cleaning**  
Equipped with its own drainage system in the front profile. This is convenient in case of rain but also when cleaning the fabric once or twice a year with the Thule PVC Cleaner.

**4 - Perfect fabric tension**  
Sturdy spring arms with patented integrated tension arms ensure a perfectly tensioned awning fabric for increased wind resistance.

**Thule Pitch System**  
The incline of the awning fabric can be set as you please to easily open the sliding door of your van without touching the awning fabric.

**3 - Thule Quick Lock System**  
User-friendly system to help you set up and adjust the support legs to the right heights.

Cassette Finishes	Fabric Color
 Anodized	 31*  03*
 White	 32*  04*
 Anthracite	 22*

Length	Projection	Weight
2.60 m	2.00 m	19.60 kg
3.00 m	2.50 m	23.00 kg
3.25 m		24.00 kg
3.50 m		25.40 kg
3.75 m		27.00 kg
4.00 m		29.00 kg
4.25 m	2.50 m	30.20 kg
4.50 m		31.40 kg
5.00 m		35.60 kg

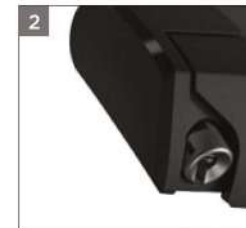
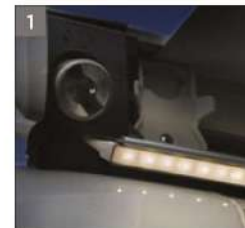

\*When choosing fabric, please consult your Termosa sales consultant.

NOTE - When it rains, put down a support leg so the water can drain away easily.



**Thule Tent LED Mounting Rail TO 6300**

**TH301664** - This profile can be slid at the bottom of the Thule Omnistor 6300 | 6200 | 9200 roof awning cassette. Provided with a channel to slide a Thule tent or the Thule organizers in and has additional space for a Thule LED Strip. The LED Light can be used both when the awning is opened or closed.

- Length: 4 m
- Color: Black

NOTE - Only compatible with Thule LED Strip Sideways



**Thule Tent LED Mounting Rail TO 5200**

This aluminium profile covers the adapters and is provided with a channel to slide a Thule tent or the Thule Organizers in and has additional space for a Thule LED Strip. The LED light can be used both when the awning is opened or closed.

- Available in different lengths
- Colours: anthracite, anodised and white



**Thule LED Strip Sideways**

**TH301660** - Long lasting and waterproof (IP65) LED strip to offer strong natural sideways light (60 power LEDs per meter). The flexible unit can be shortened each 5 cm and is delivered with a 3M tape on the back to stick to most standard surfaces.

- Voltage: 12 VDC
- Consumption: 340-380 mA per metre
- Length: 4.00 m



**Thule LED Strip**

Long lasting and waterproof (IP65) LED strip to offer strong warm white light (60 power LEDs per meter). The flexible unit can be shortened each 5 cm and is delivered with a 3M tape on the back to stick to most standard surfaces.

- Voltage: 12 VDC
- Consumption: 340-380 mA per metre
- **TH307136** - 5 m
- **TH307135** - 4 m
- **TH307137** - 6 m



**Thule LED Mounting Rail TO 6300/6200/9200**

**TH306777** - Profile to fit the opening in the bottom of the Thule Omnistor 6300 | 6200 | 9200 roof awning cassette for the installation of a Thule LED Strip. The minimum required distance between the roof and the underside of the awning must be 12 mm.





**Thule Motor Kit TO 5200**

Retrofit motor kit (12 VDC) for Thule Omnistor 5200 awning lengths from 3.00 m and more. Includes a switch with one touch command.

- Weight: 1kg
- **TH301296** - White
- **TH301297** - Anodized
- **TH301298** - Black



**Thule Sealing Rubber**

Ensures that the gap between the vehicle and wall awning is sealed when using a flat adapter. Fitted with an integrated drainage system.

- Length: 4 m
- **TH307960** - Seri Thule Omnistor 5 & 8 - small 5 cm
- **TH307961** - Thule Omnistor 5 & 8 - large 8 cm
- **TH306892** - Thule Omnistor 4900 - medium 6 cm



**Thule Motorkit 230V EM TO 8000/9200**

Retrofit motor kit (230 VAC EM) for awnings Thule Omnistor 8000 | 9200. Includes a remote control and relay.

**Thule Omnistor 8000**

- **TH307924** - White
- **TH307925** - Anodized
- **TH307926** - Cream

**Thule Omnistor 9200**

- **TH306772** - White
- **TH306773** - Anodized
- **TH306774** - Cream



**Thule EPDM**

**308697** - Black EPDM foam strip with closed cell structure to seal the gap between the vehicle and a roof-mounted awning.

- Length: 2x2 m
- Thickness : 25 mm
- Width: 30 mm
- **TH308697**



**Thule Gutter**

This self-adhesive drainage system fits most caravans and motorhomes.

- **TH307947** - Length: 3.50 m
- **TH307967** - Length: 4.50 m





Create additional privacy under your awning by easily attaching one or more smart panels to your awning. Moreover these panels protect you against sun, rain and wind and can be combined in many ways for an optimal protection.



**Thule Sun Blocker G2**

- Protection against the sun
- Micro-air curtain fabric
- Front and side panels



**Thule Rain Blocker G2**

- Protection against rain and wind
- Top quality PVC fabric
- Front and side panels



**Thule View Blocker G2**

- Protection against rain, wind and sun
- Top quality PVC fabric
- Side panel



**Thule Wind Blocker**

- Protection against wind
- Micro-air curtain fabric
- Side panel



**PROTECTION AGAINST SUN**

Awning	Length	A - Mounting Height	H - Incline	Code
TO 5200/4900/5102/6200/5003	2.00 m	1.90 - 2.24 m Small	21 cm	307399
TO 5200/4900/6200/5003	2.50 m	2.25 - 2.44 m Medium	23 cm	307278
TO 1200		2.25 - 2.49 m TO 1200	48 cm	307279
TO 8000/6900	2.75 m	2.25 - 2.44 m Medium	23 cm	307398
		2.25 - 2.44 m Medium	23 cm	307280
TO 9200	3.00 m	2.45 - 2.64 m Large	43 cm	307281
		2.45 - 2.64 m Large	43 cm	307282
		2.45 - 2.64 m Large	43 cm	307283

A = Distance between the bottom of the awning cassette and the chassis



**PROTECTION AGAINST RAIN, WIND AND SUN**

Awning	Length	A - Mounting Height	H - Incline	Code
TO 5200/4900/6200/5003	2.50 m	2.25 - 2.44 m Medium	23 cm	308380
		2.45 - 2.64 m Large	43 cm	308381

A = Distance between the bottom of the awning cassette and the chassis



**PROTECTION AGAINST RAIN AND WIND**

Awning	Length	A - Mounting Height	H - Incline	Code
TO 5200/4900/5102 on a van	2.00 m	1.80 - 1.99 m X-Small*	21 cm	306515
TO 5200/4900/6200/5003		2.05 - 2.24 m Small**	23 cm	301422
TO 5200/4900/6200/5003	2.50 m	2.05 - 2.24 m Small**	23 cm	307291
		2.25 - 2.44 m Medium	23 cm	307297
		2.45 - 2.64 m Large	43 cm	307400
		2.65 - 2.84 m X-Large	63 cm	307295
TO 1200		2.35 - 2.54 m TO 1200 V2**	50 cm	307293
TO 6200 - Ducato		2.30 - 2.50 m Ducato	37 cm	307298
TO 8000/6900	2.75 m	2.25 - 2.44 m Medium	23 cm	307300
		2.45 - 2.64 m Large	43 cm	307302
		2.65 - 2.84 m X-Large	63 cm	307292
		2.85 - 3.04 m XX-Large	83 cm	306516
TO 9200	3.00 m	2.25 - 2.44 m Medium	23 cm	307296
		2.45 - 2.64 m Large	43 cm	307294
		2.65 - 2.84 m X-Large	63 cm	307299
		2.85 - 3.04 m XX-Large	83 cm	306517

\* Can be combined with Thule Rain Blocker G2 Front - Height: 1.85 m

\*\* Can be combined with Thule Rain Blocker G2 Front - Height: 2.10 m It is not possible to use it with the Thule QuickFit tent.

**NOTE** - Thule Rain Block G1 Side Panels are available for the Thule Omnistor Caravan, Caravan Style and 2000 model.

## WHICH THULE SMART PANELS ARE RIGHT FOR YOU?



### PROTECTION AGAINST SUN

Awning	Length	Height	Code
For all Thule Omnistor awning models	1.00 m	1.70 m	307284
	2.40 m		307285
	2.80 m		307286
	3.30 m		307287
	3.80 m		307288
	4.30 m		307289
	4.80 m		307290

**NOTE** - Can be used with Thule Residence G3 tent with optional connection profiles - TH301567



### PROTECTION AGAINST RAIN, WIND AND SUN

Awning	Length	Height	Code
For all Thule Omnistor awning models	2.40 m	1.40 m	307588
	2.80 m		307592
	3.30 m		307594
	3.80 m		307596
	4.30 m		307598
	4.80 m		307600

**NOTE** - Can be used with Thule Residence G3 tent with optional connection profiles - TH301567



### PROTECTION AGAINST RAIN AND WIND



Awning	Length	Height	Code
<b>Combine with Side Panel: X-Small</b>			
TO 5200/4900/5102 on a van	1.30 m	1.85 m	306454
<b>Combine with Side Panels: Small and 1200 V2 models</b>			
For all Thule Omnistor awning models	1.25 m	2.10 m	301320
	1.50 m		301321
	1.75 m		301322
	2.00 m		301323
<b>Combine with Side Panels: Medium, Large, X-Large and XX-Large</b>			
All Thule Omnistor models	1.25 m	2.30 m	307303
	1.50 m		307304
	1.75 m		307305
	2.00 m		307306





**LONG STAY**

**Thule Panorama**

- You can fully remove the large front and side windows or open them vertically to use as a door, or horizontally to let the fresh air in



**LONG STAY**

**Thule Residence G3**

- The window panels can be rolled upwards
- Front panels starting from 3.50 m length have a door opening on both sides and can also be rolled up separately for easy entrance
- It is possible to add accessories in the optional rail at the front panel



**SHORT STAY**

**Thule QuickFit**

- All sides are fully zippable
- They can be taken away to create an open porch, can be opened sideways to create a door on all sides, left or right and can be opened from top to bottom to create an open window

An RV tent gives you the perfect outdoor living space. The highly versatile and easy-to-set-up range of Thule awning tents offers an option to suit every need

**EASY INSTALLATION**



**Transform your awning into a complete tent:**

The awning becomes your roof when you add the side panels by means of an aluminium rafter. Attach the mast profile to ensure the perfect sealing to your vehicle. Easily slide the front panels in the lead rail and connect all panels.



**Short Stay: Thule QuickFit**

This tent exists of 1 piece and takes only 15 minutes to set up. Slide it in the caravan rail or in an additional rail below your awning cassette and fix it to the awning lead rail. In this way you create a double roof which offers a good insulation to keep the tent and vehicle cool. Side windows are provided with mosquito mesh



**Stability and security (1)**

Depending on the awning tent type, Thule uses different durable high quality fabric materials: Airtex®, PVC or Ripstop that provide wind and water tightness. Moreover all Thule awning tents are tested in various weather conditions to guarantee optimal stability and security.

**Innovative design: (2)**

Thule awning tents have a contemporary design in line with the awning design. Thanks to the combination of neutral **colours:** black, white, grey and silver, they suit all awning fabric colours. Large windows invite maximum light and create an extra feeling of spaciousness. Permanent ventilation openings reduce condensation

**Modularity:**

Thanks to the clever design, the awning tents can be installed completely but most of the panels are unzippable and removable to create door openings on different sides.

# WHICH THULE TENT IS RIGHT FOR YOU?

## Long Stay



## Short Stay



Araç Tipi	Thule Panorama	Thule Residence G3	Thule QuickFit
Motorhome			
Caravan			
Van	Ducato H2	VW T5/T6	Ducato H2
Awning	<b>Thule Omnistor</b>	<b>Thule Omnistor</b>	<b>Thule Omnistor</b>
	5200 8000	5200 8000	5200 8000
	9200 6200	4900 5102	4900 9200
	5003 5002	9200 6200	6200 1200
	5500 6900	5003 5002	5003 5002
	6002	5500 6900	5500 6900
		6002	6002
			+ Others
Maximum tent length	6.00 m	6.00 m	3.60 m
Mounting height	2.30 m - 2.74 m	2.15 m - 3.10 m	2.25 m - 2.84 m
Tent installation time	Fast	Fast	Ultra-fast
Material	AIRTEX® material	PVC material	RIPSTOP material
Curtain	Optional	Optional	Including
Wind blocker	Including	Included (with front panel)	Including
wheel cover	Optional (Ducato H2 Including)	Optional	Including
Storage bag	2 luxury bags	2 luxury bags (including side panels)	sport bag

## DOORS AND WINDOWS

---

WINDOWS  
DOORS





## DOUBLE FOLDED SLIDING WINDOWS



- Double dark acrylic glass
- UV resistant
- E certified PMMA glass compatible with European standards
- Durable and lightweight aluminum frame with electrostatic coating
- Waterproof EPDM rubber gasket used in assembly
- Easy to use armband
- Compatible with 25-35, 35-45 and 50-60 mm thick walls
- Mounting within the wall (mounting is done without drilling a hole in the wall)
- With curtain and fly screen
- Smoother acrylic, PMMA glass
- Privacy, sun protection and pest protection
- The fly screen system, which is moved by steel ropes, is durable and long-lasting.
- Durable magnet system that can be used with one hand
- Shockproof outer casing
- There are no visible screws

DIMENSIONS	CODES
300x500 mm	BR300500-SC
350x600 mm	BR350600-SC
450x1100 mm	BR4501100-SC
550x900 mm	BR550900-SC

## RUBBER FRAME WINDOWS (WITHOUT METAL FRAME)



### Maximum insulation with rubber frame!

- It has an opening angle of 80 degrees
- Can be stopped and fixed at the desired angle
- With curtain and fly screen
- It is very easy to install
- Once the area is cut, simply embed the window and mount the rubber frame
- With its acrylic double glass feature, it is resistant to UV rays and provides maximum heat protection.
- It has the highest level of water resistance with its rubber gasket.
- It is the lightest in its class thanks to its compatibility with different frames.
- Thanks to the useful plastic handles, opening and closing is most comfortable.
- High-strength security locks with child locks
- Comfortable use with summer and winter modes
- Compatible with 26-29, 30-33, 34-37, 37-40 mm thick walls

DIMENSIONS	CODES
300x500 mm	BR300500-RF
360x720 mm	BR360720-RF
500x900 mm	BR500900-RF
550x700 mm	BR550700-RF
600x1250 mm	BR6001250-RF

## INCLINED CARAVAN WINDOW



- High viewing angle
- Stylish design
- Particularly suitable for the front parts of motorhomes and caravans
- Double dark acrylic glass
- UV resistant
- E certified PMMA glass compatible with European standards
- With curtain and fly screen
- Smoother acrylic, PMMA glass
- Privacy, sun protection and pest protection
- The fly screen system, which is moved by steel ropes, is durable and long-lasting.

### Technical Specifications:

External Dimension (600900): 732x1265 mm  
 Internal Dimension (600900): 762x1065 mm  
 External Dimension (570565): 695x927 mm  
 Internal Dimension (570565): 723x728 mm  
 Mounting Thickness: 30-31 or 35-36 mm  
 Openable Angle: 45°C

<b>Code</b>	BR600900-C 600x900 mm
-------------	--------------------------

<b>Code</b>	BR570565-C 570x565 mm
-------------	--------------------------

**NEW**



- Double dark acrylic, UV resistant
- Durable and lightweight aluminum frame with electrostatic coating
- Water-proof EPDM rubber gasket used in assembly
- Optional angular outward opening with telescopic support
- Easy to use armband
- Compatible with walls of 25-30, 30-35, 35-40, 40-45, 45-50 and 50-55 mm thickness
- Compatible with different curtains
- With curtain and fly screen
- Shock absorbers that can be stopped and opened at any point
- High-strength security locks with child locks
- Smoother acrylic, PMMA glass
- Perfect drainage thanks to water channels on the outer frame
- Durable and long-lasting
- Durable magnet system that can be used with one hand
- Shockproof outer casing and easy installation

## WINDOWS WITH BLACK INSIDE FRAME



DIMENSIONS	CODE
300x500 mm	JR3050F-B
300x700 mm	JR3070F-B
350x600 mm	JR3560F-B
450x500 mm	JR4550F-B
450x610 mm	JR4561F-B
450x900 mm	JR4590F-B
450x1100 mm	JR45110F-B
500x300 mm	JR5030F-B
500x900 mm	JR5090F-B
500x1200 mm	JR50120F-B
550x1450 mm	JR55145F-B
600x350 mm	JR6035F-B
900x900 mm	JR9090F-B

## WINDOWS WITH WHITE INSIDE FRAME



DIMENSIONS	CODE
300x500 mm	JR3050FW
300x700 mm	JR3070FW
350x600 mm	JR3560FW
450x500 mm	JR4550FW
450x610 mm	JR4561FW
450x900 mm	JR4590FW
450x1100 mm	JR45110FW
500x300 mm	JR5030FW
500x900 mm	JR5090FW
500x1200 mm	JR50120FW
550x1450 mm	JR55145FW
600x350 mm	JR6035FW
900x900 mm	JR9090FW





## ■ HARTAL®

**With more than 340 employees, 100,000 manufactured doors and more than 34 million in sales per year, HARTAL currently have 60% market share in Europe.**

### **HARTAL RV DOORS**

Hartal's lightweight aluminium clamping frame construction with stable internal hinges and a security locking system with additional dead bolts, forms the basis for the door construction.

They offer the modern camping enthusiast a high degree of comfort when it comes to doors. They make use of automotive design elements and incorporate many practical functions tailored to the user's needs.

Of course, every door is foamed with especially heat-insulating PU foam and features lifelong pre-tension qualities thanks to optimal tool design. All doors are manufactured individually according to the customer's requirements and are delivered directly to the production line together with the appropriate insect screen.



The upper door and lower door can be opened separately. This feature ensures that your children and pets stay safe.



With the 12V connection, you can easily unlock the door remotely with a single button.



MODEL 1		
<b>Code</b>	HT17.8440.8243	HT17.8240.8244
	Opens to the right	Opens to the left
<b>Measurement</b>	1754x580 mm	

MODEL 2		
<b>Code</b>	HT17.8243.8239	HT17.8243.8241
	Opens to the right	Opens to the left
<b>Measurement</b>	1717x550 mm	

MODEL 3	
<b>Code</b>	HT17.8005.8259
<b>Measurement</b>	1925x570 mm



MODEL 4	
<b>Code</b>	HT17.8005.8229
<b>Measurement</b>	1754x660 mm



MODEL 5	
<b>Code</b>	HT17.8006.8274
<b>Measurement</b>	1925x570 mm

- Thanks to the 12V connection, you can easily unlock the door remotely with a single button.

## ROOF VENTS

---

A holiday with plenty of light and fresh air is the basic need of every camper.







**VISIONSTAR L PRO (50x70)**



**Code** MP7503PSW

- Smoked polycarbonate rooflight with double glazing
- Optionally with and without continuous ventilation
- Attractive interior frame with double pleated blinds
- Easy one-handed operation with bow handle
- Steplessly adjustable up to 55°
- Flat dome (only 105 mm above ground)
- Greatly reduced driving noise and draught
- Double-walled frame for better insulation
- Continuous ventilation even with pleated blinds closed
- High UV protection due to tinted dome material
- Robust domes made of impact-resistant polycarbonate

**Technical Specifications**

Cut-out dimension	: 500x700 mm
Corner radius	: 23 mm
Dome size	: 815x583 mm
Continuous ventilation	: 150 cm <sup>2</sup> 'ye kadar
Height above roof	: 105 mm
Frame dimensions	: 872x37x610 mm
Weight	: 8185 gr

**VISIONSTAR L PRO LED (50x70)**



**Code** MP7503PLSW

- Energy-saving LED lighting
- Dimmable LEDs (dimmer BD1209)
- High brightness, warm white light color
- Diffusing glass for good light distribution
- Improved noise reduction
- Smoked polycarbonate rooflight with double glazing
- Optionally with and without continuous ventilation
- Attractive interior frame with double pleated blinds
- Easy one-handed operation with bow handle
- Steplessly adjustable up to 55°
- Flat dome (only 105 mm above ground)
- Greatly reduced driving noise and draught
- Double-walled frame for better insulation
- Continuous ventilation even with pleated blinds closed
- High UV protection due to tinted dome material
- Robust domes made of impact-resistant polycarbonate

**Technical Specifications**

Cut-out dimension	: 500x700 mm
Corner radius	: 23 mm
Dome size	: 815x707 mm
Continuous ventilation	: 150 cm <sup>2</sup> 'ye kadar
Çatı kalınlığı	: 25-60 mm
Height above roof	: 105 mm
Frame dimensions	: 872x37x650 mm
Weight	: 8485 gr

**LED Özellikleri (575x2,5x9mm)**

Light colour	: ~ 3000K
Energy efficiency class	: A+
Nom. useful luminous flux	: 2x500 lm
Mains voltage	: 12 - 14V DC
Consumption	: 2x5,6 kW/h / 1 000h
Nominal service life	: 10.000 saat
Nomin. Half-value angle	: 60°
(Not suitable for accent lighting)	: 60°
Number of switching cycles	: 50.000

**VISIONSTAR M PRO 2 (40x40)**



**Code** MP4903PSW

- Smoked polycarbonate rooflight with double glazing
- Optionally with and without continuous ventilation
- Attractive interior frame with double pleated blinds new improved mechanics
- Steplessly adjustable up to 50°
- Very flat rooflight (only 80 mm above roof)
- Greatly reduced driving noise and draught
- Double-walled frame for better insulation
- Continuous ventilation even with pleated blinds closed
- High UV protection due to tinted dome material
- Robust domes made of impact-resistant polycarbonate

**Technical Specifications**

Cut-out dimension : 400x400 mm  
 Corner radius : 28 mm  
 Dome size : 490x470 mm  
 Continuous ventilation : 150 cm<sup>3</sup>/e kadar  
 Height above roof : 80 mm  
 Frame dimensions : 565x35x530 mm  
 Weight : 3760 gr

**VISIONSTAR M PRO 2 LED (40x40)**



**Code** MP4903PLSW

- Energy-saving LED lighting
- Dimmable LEDs (dimmer BD1209)
- High brightness, warm white light color
- Diffusing glass for good light distribution
- Improved noise reduction
- Smoked polycarbonate rooflight with double glazing
- Optionally with and without continuous ventilation
- Attractive interior frame with double pleated blinds new improved mechanics
- Steplessly adjustable up to 50°
- Very flat rooflight (only 80 mm above roof)
- Greatly reduced driving noise and draught
- Double-walled frame for better insulation
- Continuous ventilation even with pleated blinds closed
- High UV protection due to tinted dome material
- Robust domes made of impact-resistant polycarbonate

**Technical Specifications**

Cut-out dimension : 400x400 mm  
 Corner radius : 28 mm  
 Dome size : 490x470 mm  
 Continuous ventilation : 150 cm<sup>3</sup>/e kadar  
 Height above roof : 80 mm  
 Frame dimensions : 565x35x570 mm  
 Weight : 3960 gr

**LED Specifications (394x2,5x9 mm)**

Light colour : - 3000K  
 Energy efficiency class : A+  
 Nom. Useful luminous flux : 2x390 lm  
 Mains voltage : 12 - 14V DC  
 Consumption : 2x4.2 kW/h/1000h  
 Nominal service life : 10.000 saat  
 Nomin. Half-value angle  
 (Not suitable for accent lighting) : 60°  
 Number of switching cycles : 50.000

**ROOFLIGHT ECO - MODEL 42 (40x40)**

**NEW**



**Code** MP420VNW

- Small, space-saving milk glass dome made of polypropylene
- Telescopic display unit, tiltable on four sides, with locking device
- Optionally with double roller blind combination frame (470x470x14 mm), folding net frame with or without blackout roller blind or pleated frame (also with LED).
- Approval: ECE R43 -019649

**Technical Specifications**

Cut-out dimension : 400 x 400 mm  
 Dome size : 480 x 480 mm  
 Corner radius : 28 mm  
 Free air flow : 150 cm<sup>2</sup>  
 Height above roof : 91 mm

**ROOFLIGHT - MODEL 29 (28x28)**

**NEW**



**Code** MP290VNW

- Small, space-saving milk glass dome made of polypropylene
- Telescopic display unit, tiltable on four sides, with locking device
- Folding frame with mosquito net, roller blind optional
- Optionally also with double pleated inner frame

**Technical Specifications**

Cut-out dimension : 280x280 mm  
 Corner radius : 18 mm  
 Dome size : 330 x 330 mm  
 Continuous ventilation : 60 cm<sup>2</sup>  
 Height above roof : 78 mm  
 Roof thicknesses : 22-46 mm  
 Frame dimensions : 315 x 8 x 315 mm  
 Weight : 1180 gr

**VISIONVENT S PRO (28x28)**

**NEW**



**Code** MP2753VPSW  
 With Sunvisor and Fly Screen

**Code** MP2753VPSNW  
 With Fly Screen

- Large dome for rain protection
- High UV protection due to tinted dome material
- Telescopic display unit, tiltable on four sides, with locking device
- Modern interior frame with double pleated blind
- Approval: ECE R43 -019652
- Condensation water protection:
- Covered ventilation in inner dome with condensation stop
- Air cushion reduces drop formation
- Channels drain off condensation water
- Aerodynamic dome
- Lower driving noise
- Less draught despite continuous ventilation

**Technical Specifications**

Cut-out dimension : 280x280 mm  
 Corner radius : 28 mm  
 Dome size : 380x395 mm  
 Continuous ventilation : 75 cm<sup>2</sup>  
 Height above roof : 80 mm  
 Roof thicknesses : 24-46 mm  
 Frame dimensions : 365 x 32 x 340 mm  
 Weight : 1800 gr

**VISIONVENT S ECO (28x28)**



**Code** MP2753VNSW

- Large dome for rain protection
- High UV protection due to tinted dome material
- Telescopic display unit, tiltable on four sides, with locking device
- Folding frame with mosquito net, roller blind optional
- Covered ventilation in inner dome
- with condensation stop
- Air cushion reduces drop formation
- Channels drain off condensation water aerodynamic dome lower driving noise
- Less draught despite continuous ventilation

**Technical Specifications**

Cut-out dimension : 280x280 mm  
 Corner radius : 28 mm  
 Dome size : 380x395 mm  
 Continuous ventilation : 75 cm<sup>2</sup>  
 Height above roof : 80 mm  
 Roof thicknesses : 24-46 mm  
 Frame dimensions : 315 x 8 x 315 mm  
 Weight : 1500 gr

**TURBO VENT (28x28)**



**Code** RH280280

- 28x28 ventilation is ideal for small spaces.
- 28x28 ventilation is the ideal size for ventilating small areas of your caravan, such as bathrooms and kitchens, with fresh air.
- Manufactured from high quality, impact resistant and UV resistant materials.
- Fly protection fly screen is included. The external aerodynamic cover guarantees a water-repellent feature.
- Air circulation both indoors and outdoors.

**Technical Specifications**

Cut-out dimension : 280x280 mm  
 Weight : 2.19 kg  
 Current : 12 V Fan

**MUSHROOM HILL TYPE VENTILATION**



You can use mushroom top type ventilation for air evacuation.

**Code** MP-K1006W

**FLOOR VENT**



**Code** MP5060W  
Upside

**Code** MP5061W  
Under Part

- Simple to install; screw base under floor, push top over base
- Top pulls off for cleaning
- Protects against road splash
- Narrow venting slots deters insects and vermin
- Ducting hoses can be fitted to the top

**Technical Specifications**

Ventilation shaft : ca. 20 cm<sup>2</sup>  
 Floor thickness : 33 - 65 mm  
 Floor cut-out : Ø 60 mm  
 Weight : 35 gr

# WINDOW BLIND FLYSCREEN

---

WINDOW BLIND  
FLYSCREEN



**WINDOW BLIND**



**Code** LP2021104602  
Front window

**Code** LP2021104606  
Side Window

- FIAT Ducato X290/X250 / V8
- Retractable, pleated blind to keep vehicle interior blacked-out while parked

**SKIA PRIVACT - WINDSHIELD BLIND**



- Attaches to the bottom of SKIA windshield blind to block all light from entering the vehicle cabin
- Available in two colors to match SKIA

**Code** LP2023038718

**FLYSCREEN**



**Code** LP2021104600

Aluminum sliding van flyscreen with low, walkable, L-shaped guide

- FIAT Ducato X290/X250 / V8
- Keeps out insects and debris while allowing fresh airflow
- Clutched sliding system allows the screen to be opened to any position
- Vanscreen should be left open while van door is closed to avoid obstruction
- Works independently of sliding door
- Right-hand door option is available upon request
- Fire-proof fabric options

## SERVICE DOORS

The service door of cassette toilets can be used as a tank cover. With the Thetford service door, you can gain extra easy access to certain areas of the caravan. All models are manufactured using highly lightweight plastic, making them extremely durable.







**Technical Specifications**

Dimension : 385x335 mm

- With the Thetford Service Door, you can provide extra and easy access to certain areas of the caravan.
- All models are manufactured using high-grade, lightweight plastic, making them extremely durable.
- Service Door 3, a compact, universal door, is the standard door for cassette toilets.

**SERVICE DOOR 3**

**Code** TF2680580 (White)

**Code** TF2680527 (Black)



**Technical Specifications**

Dimension : 700x395 mm

- With the Thetford Service Door, you can provide extra and easy access to certain areas of the caravan.
- All models are manufactured using high-grade, lightweight plastic, making them extremely durable.
- Service Door 4 is ideal for accessing gas cylinders and water tanks.

**SERVICE DOOR 4**

**Code** TF2681880 (White)

**Code** TF2681827 (Black)



**Technical Specifications**

Dimension : 785x340 mm

- With the Thetford Service Door, you can provide extra and easy access to certain areas of the caravan.
- All models are manufactured using high-grade, lightweight plastic, making them extremely durable.
- Service Door 5 is suitable for access to the water tank or as a general tailgate.

**SERVICE DOOR 5**

**Code** TF2682480 (White)

**Code** TF2682427 (Black)



**Technical Specifications**

Dimension : 1038x465 mm

- With the Thetford Service Door, you can provide extra and easy access to certain areas of the caravan.
- All models are manufactured using high-grade, lightweight plastic, making them extremely durable.
- Service Door 6 is perfect for accessing a storage area for large items or for use as a general tailgate.

**SERVICE DOOR 4**

**Code** TF2686480 (White)

**Code** TF2686427 (Black)



**Technical Specifications**

Dimension : 1108x346 mm

- With the Thetford Service Door, you can provide extra and easy access to certain areas of the caravan.
- All models are manufactured using high-grade, lightweight plastic, making them extremely durable.
- Shuttle Door 7 is perfect for accessing a storage area for large items like camping tables and chairs or for use as a general tailgate.

**SERVICE DOOR 4**

**Code** TF2644580 (White)

**Code** TF2644527 (Black)



# KITCHEN

REFRIGERATORS

OVENS

ASPIRATORS

COOKERS

POT HOLDERS

SINKS

WATER DRAINS

FAUCETS



# THETFORD

## T2000 series



**Fits perfectly in all caravans**

## Touch control panel





**New T2000 Series  
Fits perfectly in all caravans**

Thetford identified some changes in the caravan world, including carefree travel, electrification and a growing emphasis on home comfort in recreational vehicles. The new T2000 series 12V refrigerators fit perfectly into this change. They offer better performance, a lighter cooling unit and more usable volume.

- Touch control panel
- Most efficient cooling power thanks to Automatic Temperature Control (ATC)
- Designed to operate very quietly
- Integrated ventilation for easy plug and play
- Separate freezer arrangement
- Sliding partition
- Shelf food holders
- Recessed door handle
- Changeable door direction
- Frozen food drawer
- Cooling unit at the bottom
- Bottle and vegetable drawer
- Higher usable volume compared to a 3-system refrigerator of the same size
- Lower weight compared to a 3-system refrigerator of the same size
- More powerful performance compared to a 3-system refrigerator of the same size
- Low energy consumption with night mode

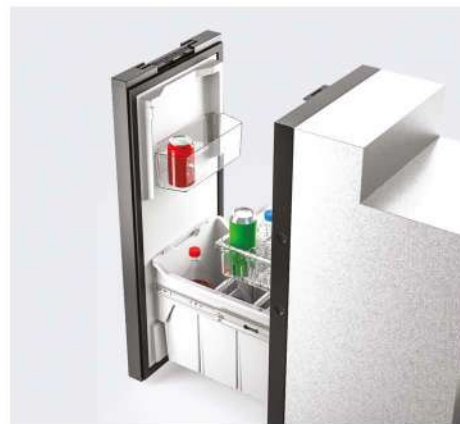
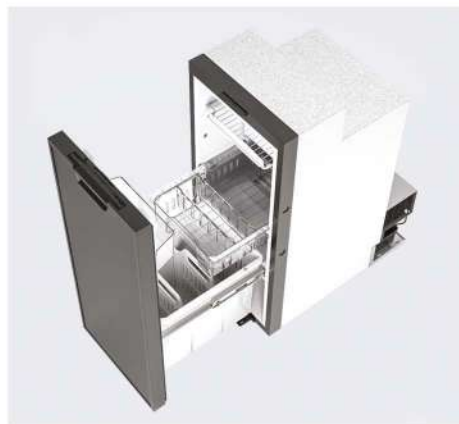

- The new T2095 refrigerator offers sliding usage and large interior volume. This way, you can bury it under your kitchen counter.
- Suitable for double-sided use
- Two-way accessibility
- With the sliding door, you can reach it easily by leaning less.
- You can mount the newly designed control panel of the new T2090-E refrigerator wherever you want.

**COMPRESSOR REFRIGERATOR**

T2090



**Code** TF692932SP

**Technical Specifications**

Control panel : Touch  
 Dimensions (WxHxD) : 418x975x486 mm  
 Door type : Flat frame  
 Door hinge direction : Right  
 Energy consumption : 0,34 kWh/24h  
 Voltage : 12 volt  
 Freezer volume : 6.1 liters  
 Cooling technology : Compressor refrigerator  
 Total volume : 90 liters  
 Refrigerant type : R-600a (isobutane)  
 Net weight : 21.1 kg

**Note:** You can use the refrigerator door on the left or right.

**COMPRESSOR REFRIGERATOR**

T2090-E

**NEW**



**Code** TF692965SP

You can mount the newly designed control panel of the T2090-E refrigerator wherever you want.

**Technical Specifications**

Control Panel : Touch  
 Dimensions (WxHxD) : 418x925x486 mm  
 Door type : Flat frame  
 Door hinge direction : Sağ  
 Energy consumption : 0,34 kWh/24h  
 Voltage : 12 volt  
 Freezer volume : 6.1 liters  
 Cooling technology : Compressor refrigerator  
 Total volume : 90 liters  
 Net weight : 21.1 kg

**Note:** You can use the refrigerator door on the left or right.

**COMPRESSOR REFRIGERATOR**

T2095

**NEW**



**Code** TF692961SP

- Suitable for double-sided use
- Two-way accessibility
- The new T2095 refrigerator offers sliding usage and large interior volume. This way, you can bury it under your kitchen counter.
- With the sliding door, you can reach it easily by leaning less.

**Technical Specifications**

Control Panel : Touch (Inside the cabinet)  
 Dimensions (WxHxD) : 400x908x682 mm  
 Door type : Flat frame  
 Door hinge direction : Top  
 Energy consumption : 0,36 kWh/24h  
 Voltage : 12 volt  
 Freezer volume : 7 liters  
 Cooling technology : Compressor refrigerator  
 Total volume : 90.2 liters  
 Net weight : 33 kg

**COMPRESSOR REFRIGERATOR**

T2138



**Code** TF692545SP

**Technical Specifications**

Control Panel : Touch  
 Dimensions (WxHxD) : 418x1598x503 mm  
 Door type : Flat frame  
 Door hinge direction : Sağ  
 Energy consumption : 0.50 kWh/24h  
 Voltage : 12 volt  
 Freezer volume : 11.6 liters  
 Net weight : 36.2 kg  
 Cooling technology : Compressor refrigerator  
 Total volume : 138 liters  
 Refrigerant type : R-600a (isobutane)

**Note:** You can use the refrigerator door on the left or right.

**COMPRESSOR REFRIGERATOR**

T2152



**Code** TF692551SP

**Technical Specifications**

Control Panel : Touch  
 Dimensions (WxHxD) : 418x1500x569 mm  
 Door type : Flat frame  
 Door hinge direction : Sağ  
 Energy consumption : 0.47 kWh/24h  
 Voltage : 12 volt  
 Freezer volume : 17 liters  
 Net weight : 36.3 kg  
 Cooling technology : Compressor refrigerator  
 Total volume : 152 liters  
 Refrigerant type : R-600a (isobutane)

**Note:** You can use the refrigerator door on the left or right.

**COMPRESSOR REFRIGERATOR**

T2156



**Code** TF692940SP

The independent temperature control of the freezer compartment and the automatic temperature control function, as well as the advanced wide climate zone design, ensure that the refrigerator is always in top condition.

**Technical Specifications**

Total Volume : 142 liters  
 Freezer volume : 56 liters  
 Dimensions (WxHxD) : 418x1500x571 mm  
 Weight : 35 kg  
 Energy consumption : 0,54 kWh / 24 saat  
 Voltage : 12 Volt  
 Color : Black

**Note:** You can use the refrigerator door on the left or right.

**COMPRESSOR REFRIGERATOR**

T2160



**Code** TF692557SP

**Technical Specifications**

Control Panel : Touch  
 Dimensions (WxHxD) : 525x1245x563 mm  
 Door type : Flat frame  
 Door hinge direction : Sağ  
 Energy consumption : 0,55 kWh/24h  
 Voltage : 12 volt  
 Freezer volume : 30.5 liters  
 Net weight : 38.4 kg  
 Cooling technology : Compressor refrigerator  
 Total volume : 160 liters  
 Refrigerant type : R-600a (isobutane)

**Note:** You can use the refrigerator door on the left or right.

**COMPRESSOR REFRIGERATOR**

T2175



**Code** TF692560SP

**Technical Specifications**

Control Panel : Touch  
 Dimensions (WxHxD) : 525x1245x613 mm  
 Door type : Flat frame  
 Door hinge direction : Sağ  
 Energy consumption : 0,56 kWh/24h  
 Voltage : 12 Volt  
 Freezer volume : 33.5 liters  
 Net weight : 39.4 kg  
 Cooling technology : Compressor refrigerator  
 Total volume : 175 liters  
 Refrigerant type : R-600a (isobutane)

**Note:** You can use the refrigerator door on the left or right.

**REFRIGERATOR VENT COVER**



**Code** TF62445480

- Thetford Refrigerator provides excellent air circulation with its ventilation cover.
- This cover protects your refrigerator from cold weather and ensures its optimum performance. It also allows the refrigerator to ventilate in hot weather.
- The refrigerator engine can be accessed from outside the vehicle.
- Superior quality
- Practical use
- Long durability

**Technical Specifications**

Dimension : 483x168 mm





Planten

Ongezouten

WITTE  
ZUIVE  
SPREAD  
light  
BEELOEK  
Met milde  
yoghurt

SPREAD  
BEELOEK  
light

**COMPRESSOR REFRIGERATOR**  
12-24 V / 50 LT

**NEW**



<b>Code</b>	BR20-215015 Opens to the right
<b>Code</b>	BR20-215016 Opens to the left





<b>Code</b>	BRCOLD50-R Opens to the right
-------------	----------------------------------



**Technical Specifications**

Dimensions (WxHxD): 380x530x490 mm  
 Weight : 16.8 kg  
 Total volume : 46.5 liters  
 Freezer volume : 4.5 liters  
 Freezer : -18°C  
 Cooler capacity : 42 liters  
 Cooler : +5°C -+15°C  
 Energy : 120 / 240 V (AC) - 12 / 24 V (DC)

**COMPRESSOR REFRIGERATOR**  
12-24 V / 50 LT



<b>Code</b>	BRRV50L-R Opens to the right
<b>Code</b>	BRRV50R-L Opens to the left



**Technical Specifications**

Dimensions (WxHxD) : 380x530x490 mm  
 Weight : 16.8 kg  
 Total volume : 46.5 liters  
 Freezer volume : 4.5 liters  
 Freezer : -18°C  
 Cooler capacity : 42 liters  
 Cooler : +5°C -+15°C  
 Energy : 120 / 240 V (AC) - 12 / 24 V (DC)  
 Working power : 40W

**COMPRESSOR REFRIGERATOR**  
12-24 V / 85 LT

**NEW**



<b>Code</b>	BR20-218515 Opens to the right
<b>Code</b>	BR20-218516 Opens to the left





<b>Code</b>	BRCOLD50-R Opens to the right
-------------	----------------------------------



**Technical Specifications**

Dimensions (WxHxD) : 475x630x545 mm  
 Weight : 21 kg  
 Total volume : 78 liters  
 Freezer volume : 8 liters  
 Freezer : -18°C  
 Cooler Capacity : 70 liters  
 Cooler : +5°C -+15°C  
 Energy : 120 / 240 V (AC) - 12 / 24 V (DC)

**COMPRESSOR REFRIGERATOR**  
12-24 V / 85 LT



<b>Code</b>	BRRV85L-R Opens to the right
<b>Code</b>	BRRV85R-L Opens to the left

**SECOOP**



**Technical Specifications**

Dimensions (WxHxD) : 475x630x545 mm  
 Weight : 21 kg  
 Total volume : 78 liters  
 Freezer volume : 8 liters  
 Freezer : -18°C  
 Cooler Capacity : 70 liters  
 Cooler : +5°C - +15°C  
 Energy : 120 / 240 V (AC) - 12 / 24 V (DC)  
 Working Power : 48W

**REFRIGERATOR VENTILATION**



- Weather resistant plastic
- Can be used with or without fly screen.

**Technical Specifications**

Exterior : 365x140 mm  
 Inner: 340x115 mm  
 Free airflow: approx. 250 cm<sup>2</sup>  
 Weight: 225 gr

**Code** MP5039.1SW

**WINTER COVER FOR REFRIGERATOR VENTILATION**



- Winter cover for refrigerator ventilation 5039

**Technical Specifications**

Weight: 17 gr

**Code** MP5039.2SW

**OVEN / ASPIRE**



**Code** TFSCK13998-SP

Aspire gives you the best opportunity to prepare the best meals. It combines the stove with Gas burners, oven and grill. The grille has an innovative heat deflector to automatically prevent the fascia and buttons from overheating.

**Technical Specifications**

Product size (WxHxD) : 517x677x535 mm  
 Mounting dimensions (WxHxD) : 503x670x530 mm  
 Heat input (gas) : 7.1 kW  
 Heat input (electricity) : 0.8 kW 220V  
 Electric hotplate : 800 W  
 Fuel : Gas and electricity  
 Gas stove : 2x1.5 kW 1x1.0 kW  
 Ignition : 12V  
 Oven capacity : 37 liters  
 Grill capacity : 16 liters  
 Adjustment buttons : Matte nickel  
 Net weight : 31.5 kg

**OVEN / CAPRICE MK3 GAS**



**Code** TFSOH44998-SP

With its 3 gas burners, separate grill and separate oven, it offers you all the facilities you need for gourmet cooking.

**Technical Specifications**

Product size (WxHxD) : 463x644x500 mm  
 Mounting dimensions (WxHxD) : 445x646x493 mm  
 Heat input (gas) : 8.5 kW  
 Electric hotplate : No  
 Fuel : All gas  
 Gas stove : 2 x 1,5 kW 1 x 2,4 kW  
 Ignition : 12V  
 Oven capacity : 36 liters  
 Grill capacity : 13,7L  
 Net weight : 25 kg

**OVEN / TRIPLEX**



**Code** TFSOH70998-SP

The Triplex cooktop offers multi-functional versatility with both oven and grill and 3 oven burners; All this in a durable, lightweight and easy to clean unit.

**Technical Specifications**

Product size (WxHxD) : 463x468x500 mm  
 Mounting dimensions (WxHxD) : 445x463x493 mm  
 Heat input (gas) : 9,2 kW  
 Fuel : All gas  
 Gas stove : 2x1.18 kW 1x2.4 kW  
 Ignition : 12V  
 Oven capacity : 36 liters  
 Grill capacity : 36 liters  
 Adjustment buttons : Matte nickel  
 Net weight : 21,5 kg

**OVEN / TRIPLEX PLUS**

**NEW**



**Code** TFSOH77098-SP

The Triplex Plus hob offers multiple functions, with both oven and grill and 3 gas and 1 electric hob - all in a durable, lightweight and easy-to-clean unit.

- High-quality materials and components
- Contemporary, home-like design
- Optimum use of space

**Technical Specifications**

Dimensions (WxHxD) : 513x468x500mm  
 Mounting dimensions (WxHxD) : 496x463x493mm  
 Heat input (gas) : 5,6 kW  
 Heat input (electricity) : 800 W (Ø115 mm)  
 Electric hotplate : Var  
 Fuel : All gas  
 Gas stove : 2x1.5 kW 1x1.0 kW  
 Ignition : 12 V  
 Oven capacity : 36 Liters  
 Grill capacity : 36 Liters  
 Adjustment buttons : Matte nickel  
 Weight : 24,6 kg

**OVEN / DUPLEX**



**Code** TFSOG70998-SP

Duplex is a high quality combined oven and grill with an easy-to-clean Stainless steel interior.

- High quality materials and components
- Contemporary, home-like design
- Optimal use of space
- Superior cooking performance

**Technical Specifications**

Product dimensions (WxHxD) : 456x445x490 mm  
 Mounting dimensions (WxHxD) : 445x438x490 mm  
 Features : 2 oven racks, grill pan kit  
 Ignition : 12V  
 Open and close knobs : Matte nickel plain  
 Net weight : 14.0 kg  
 Fuel : Gas  
 Total heat input : 3,2 kW  
 Grill burner : 1.6 kW  
 Oven burner : 1.6 kW  
 Oven capacity : 36 liters

**OVEN / MIDI PRIMA 3**



**Code** TFSOP70998-SP

Midi Prima is the best of the oven and grill varieties. It is available in two heights, with or without a bottom lid, which can give you extra storage space under your oven.

**Technical Specifications**

Product size (WxHxD) : 444x644x450 mm  
 Heat input (gas) : 3,1 kW  
 Heat input (electricity) : Yok  
 Fuel : Gaz  
 Grill temperature : 1,5 kW  
 Oven temperature : 1,6 kW  
 Ignition : 12V  
 Oven capacity : 36 liters  
 Grill capacity : 13 liters  
 Adjustment buttons : Matte nickel  
 Net weight : 18 kg

**OVEN / K1540 GAS**



**Code** TFSHG41199-SP

K1540 is a new and improved design available with 4 gas stove burners. The grill can also be used with the glass lid down.

**Technical Specifications**

Product size (WxHxD) : 515x310x501 mm  
 Mounting dimensions (WxHxD) : 496x312x493 mm  
 Heat input (gas) : 9,51 kW  
 Grill temperature : 1,64 kW  
 Gas stove : 3 x 1,72 kW 1 x 0,95 kW  
 Fuel : Gas  
 Ignition : 12V  
 Grill capacity : 16 liters  
 Adjustment buttons : Matte nickel  
 Net weight : 14,5 kg  
 Adjustment buttons : Matte nickel  
 Net weight : 18 kg

**OVEN / K1540 DUEL FUEL**



**Code** TFSHG42199-SP

K1540 is a new and improved design. The grill can also be used with the glass lid down.

**Technical Specifications**

Product size (WxHxD) : 515x310x501 mm  
 Mounting dimensions (WxHxD) : 496x312x493 mm  
 Heat input (gas) : 6,0 kW  
 Grill temperature : 1,65 kW  
 Gas stove : 2 x 1,72 kW 1 x 0,95 kW  
 Electric stove : 1025 W (Ø 145mm)  
 Fuel : Gas and electricity  
 Ignition : 12V  
 Grill capacity : 15 liters  
 Hob capacity : 3x Ø120 - Ø200 mm  
 1x Ø100 - Ø200 mm  
 Adjustment buttons : Matte nickel  
 Net weight : 15,5 kg

**OVEN / K1520 GAS**



**Code** TFSC41199-SP

The new design gives the K1520 cooker a large grill, fan-assisted oven (Optional) and much more! The K1520 takes RV cooking to another level. Light, fast, big and delicious. Less weight, higher quality.

**Technical Specifications**

Dimensions (WxHxD) : 515x645x501 mm  
 Mounting dimensions (WxHxD) : 496x646x493 mm  
 Heat input (gas) : 9.6 kW  
 Electric hotplate : No  
 Fuel : All gas  
 Gas stove : 1 x 1.0 kW / 3 x 1.6 kW  
 Ignition : 12V  
 Oven capacity : 37 liters  
 Grill capacity : 15 liters  
 Adjustment buttons : Brushed nickel  
 Weight : 25 kg

**OVEN / K1520 DUEL FUEL**



**Code** TFSC42199-SP

The new design gives the K1520 cooker a large grill, fan-assisted oven (Optional) and much more! The K1520 takes RV cooking to another level. Light, fast, big and delicious. Less weight, higher quality.

**Technical Specifications**

Dimensions (WxHxD) : 515x645x501 mm  
 Mounting dimensions (WxHxD) : 496x645x493 mm  
 Heat input (gas) : 7.79 kW  
 Electric hotplate : 1025 W (Ø 145 mm)  
 Fuel : Gas and electricity  
 Gas stove : 1x 0.95 kW 2x 1.72 kW  
 Ignition : 12V  
 Oven capacity : 37 liters  
 Grill capacity : 15 liters  
 Adjustment buttons : Brushed nickel  
 Weight : 25.5 kg

**OVEN / 420**

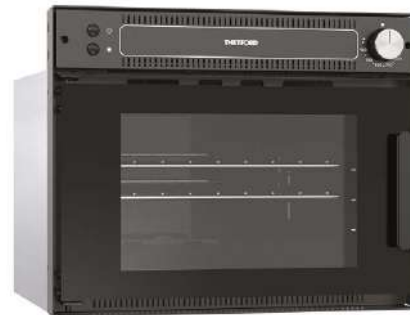

**Code** TFSOV4205-SP

With its width of 420 mm, it is suitable for small kitchens and the comfort of the oven is great. Can be mounted under the counter, at chest height or above the Thetford N3140 series refrigerator.

**Technical Specifications**

Product dimensions (WxHxD) : 418x335x440 mm  
 Mounting dimensions (WxHxD) : 420x336x580 mm  
 Heat input (gas) : 1.0 kW  
 Oven temperature : 1.0 kW  
 Fuel : Gas  
 Ignition : 12V  
 Oven capacity : 23 liters  
 Adjustment buttons : Matte nickel  
 Net weight : 10.5 kg

**OVEN / 525**



**Code** TFSOG5205-SP

The 525 Oven is made to fit 525mm wide refrigerators, making the kitchen more complete.

- Extremely easy maintenance with removable front panel
- Protruding or flush mounting
- Easy standalone installation
- Easy installation on top of a 525 mm wide refrigerator

**Technical Specifications**

Product dimensions (WxHxD) : 525x369x480 mm  
 Mounting dimensions (WxHxD) : 527x370x516 mm  
 Features : 1 Oven rack - Grill pan set  
 Grill burner : 1.5 kW  
 Ignition : 12V  
 Open and close knobs : Chrome and black cylinder  
 Net weight : 15.8 kg  
 Oven burner : 1.0 kW  
 Total heat input : 2,5 kW  
 Oven capacity : 23 liters  
 Grill capacity : Integrated into the oven cavity

**CERAMIC COOKER**

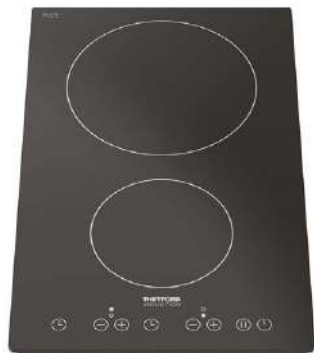

**Code** TFSHB90298-SP

Topline 902 is an induction hob with safe and easy-to-use functions developed and optimized for use in the caravan. Made from high quality Schott Ceran glass.

**Technical Specifications**

Product dimensions (WxHxD): 305x53x500 mm  
 Mounting dimensions (LxW) : 274x482 mm  
 Heat input (electricity) : 2.3 kW  
 Fuel type : 220V  
 Energy power : 220V/10A  
 Control Panel : Touch  
 Weight : 5.5 kg

**INDUCTION COOKER**



**Code** CNPI3050

It may be surprising for those unfamiliar with induction heating to see a piece of metal placed inside a coil turn red hot in seconds.

**Technical Specifications**

Product dimensions (WxHxD) : 300x60x500 mm  
 Heat input (electricity) : 1x1.2 kW 1x1.6 kW  
 Energy power : 220V  
 Control Panel : Touch  
 Weight : 5 kg

OPTIONAL  
STANDARD



Handle



Child lock



Tempered glass

**CERAMIC DOUBLE COOKER**



**Code** CNPT1356

The touch control system integrates visual effect dial control with ease of use. Cooking can be started only by using the on/off buttons. It adds different decorative features to all kitchens with its elegant design and graphic design.

**Technical Specifications**

Product dimensions (WxHxD) : 285x60x505 mm  
 Heat input (electricity) : 1x1.2 kW 1x1.8 kW  
 Energy power : 220V  
 Control Panel : Touch  
 Weight : 5 kg

OPTIONAL  
STANDARD



Handle



Child lock



Tempered glass

**VITROCERAMIC FOUR-BURN COOKER**



**Code** CNPT1358

An artistic dimension in stove technology. Innovative soft touch control, digital indicators, elegant and assertive design. In addition to its easily cleanable surface, the locking mechanism for unintentional situations, automatic shutdown, and the cooking surface protection system against excessive heat are superior features that are not found in conventional models.

**Technical Specifications**

Product dimensions (WxHxD) : 580x50x505 mm  
 Heat input (electricity) : 1x1.2 kW 1x1.6 kW  
 Energy power : 220V  
 Control Panel : Touch  
 Weight : 8 kg

OPTIONAL  
STANDARD



Handle



Child lock



Tempered glass



**CERAMIC SINGLE BURN COOKER**

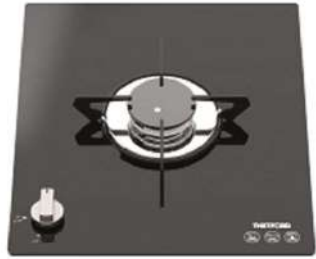

**Code** TFSHB91099-SP

Topline 910 is a powerful single-burner glass stove that allows you to cook in small spaces.

- High quality materials and components
- Contemporary, home-like design
- Optimum use of space
- Superior cooking performance

**Technical Specifications**

Product dimensions (WxHxD) : 305x95x355 mm  
 Mounting dimensions (WxD) : 285x 355 mm  
 Gas outlet temperature : 1,5 kW  
 Gas type : All gas  
 Hob temperature : 1x1.5 kW  
 Ignition : 12V  
 Hob material : Black glass  
 Hob knobs : Matte nickel  
 Weight : 4 kg

**CERAMIC DOUBLE BUBBLE COOKER**



**Code** TFSHB92298-SP

Topline 922 is a powerful two-burner glass hob to give your kitchen a modern and clean look.

- High quality materials and components
- Contemporary, home-like design
- Optimum use of space
- Superior cooking performance

**Technical Specifications**

Product dimensions (WxHxD) : 305x95x500 mm  
 Mounting dimensions (WxD) : 485x285 mm  
 Gas outlet temperature : 3.0 kW  
 Gas type : All gas  
 Hob temperature : 2x1.5 kW  
 Ignition : 12V  
 Hob material : Black glass  
 Hob knobs : Matte nickel  
 Weight : 5 kg

**CERAMIC THREE-BURN COOKER**



**Code** TFSHB93199-SP

Topline 931 is a powerful glass hob with three different sized burners to give you complete flexibility in the food you cook and give your kitchen a modern and clean look.

- High quality materials and components
- Contemporary, home-like design
- Optimum use of space
- Superior cooking performance

**Technical Specifications**

Product dimensions (WxHxD) : 770x95x350 mm  
 Mounting dimensions (WxD) : 740x322 mm  
 Gas outlet temperature : 5.0 kW  
 Gas type : All gas  
 Hob temperature : 1x1 kW 1x1.5 Kw 1x2.5 kW  
 Ignition : 12V  
 Hob material : Black glass  
 Hob knobs : Matte nickel  
 Weight : 6 kg

**CERAMIC THREE-BURN COOKER**

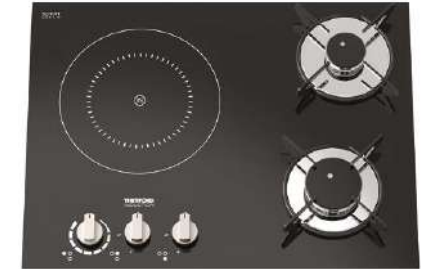

**Code** TFSHB98199-SP

Topline 981 is a true “Hybrid”, a unique combination of gas and induction cooking in the most compact size to fit your kitchen. Made from high quality Schott Ceran glass. A new right-hand version has been added, where the induction zone is located on the right side of the stove.

- High quality materials and components
- Contemporary, home-like design
- Optimum use of space
- Superior cooking performance

**Technical Specifications**

Product dimensions (WxHxD) : 500x100x380 mm  
 Mounting dimensions (WxD) : 480x360 mm  
 Gas outlet temperature : 2.5 kW  
 Electrical output heat : 1.4 kW  
 Gas type : All gas  
 Gas stove temperature : 1x1.0 kW 1x1.5 kW  
 Electric stove temperature : 1x1.4 kW  
 Ignition : 12V  
 Energy consumption : 220V/7A  
 Hob material : Black ceramic glass  
 Hob knobs : Matte nickel  
 Weight : 6.5 kg

**CERAMIC FOUR-BURN COOKER**



**Code** TFSHB94999-SP

The newly designed 9 Series is a real eye-catcher with its glass surface and individual pan supports.

- High quality materials and components
- Contemporary, home-like design
- Optimum use of space
- Superior cooking performance

**Technical Specifications**

Product dimensions (WxHxD) : 540x125x480 mm  
 Mounting dimensions (WxD) : 490x 455 mm  
 Gas outlet temperature : 6.0 kW  
 Gas type : All gas  
 Hob temperature : 4x1.5 kW  
 Ignition : 12V  
 Hob material : Black glass  
 Hob knobs : Matte nickel  
 Weight : 8 kg

**POT HOLDER (WITH SCREW PORT)**



<b>Code</b>	CNPV1370 Single stove holder
<b>Code</b>	CNPV1371 Double stove holder
<b>Code</b>	CNPV1372 Triple hob holder

Stove and pot holder for safety, specially designed for boats and caravans.

**SINGLE HOLDER (SCREW TIGHTENING FROM BACK)**



**Code** CNFP1320

Stove and pot holder for safety, specially designed for boats and caravans.

**DOUBLE HOLDER (SCREW TIGHTENING FROM BACK)**



**Code** CNFP1321

Stove and pot holder for safety, specially designed for boats and caravans.

**HOB165 COOKER WITH DOUBLE GLASS LID**



<b>Code</b>	TFSHB16548-SP Glass cover opens to the back
-------------	--

The Topline 165 is a flush-mounted two-burner cooktop with a glass lid covering the burners for a clean, modern look.

- High quality materials and components
- Contemporary, home-like design
- Optimum use of space
- Superior cooking performance

**Technical Specifications**

Product dimensions (WxHxD) : 576x106x361 mm  
 Mounting dimensions (WxD) : 566x349 mm  
 Gas outlet temperature : 4.0 kW  
 Gas type : All gas  
 Hob temperature : 1x1.5 kW 1x2.5 kW  
 Ignition : 12V  
 Hob material : Black glass  
 Hob knobs : Matte nickel  
 Weight : 8 kg

**HOB169 THREE-BURNED GLASS LID COOKER**



<b>Code</b>	TFSHB16951-SP
-------------	---------------

The Topline 169 is a stylish flush-mounted hob with a glass lid covering the burners for a clean, modern look.

- High quality materials and components
- Contemporary, home-like design
- Optimum use of space
- Superior cooking performance

**Technical Specifications**

Product dimensions (WxHxD) : 546x105x482 mm  
 Mounting dimensions (WxD) : 539x473 mm  
 Gas outlet temperature : 5.5 kW  
 Gas type : All gas  
 Hob temperature : 1x2.5 kW 2x1.5 kW  
 Ignition : 12V  
 Hob material : Black glass  
 Hob knobs : Matte nickel  
 Weight : 10.5 kg

**HOB34 THREE-BURN SQUARE COOKER**



<b>Code</b>	TFSHB34598-SP
-------------	---------------

Easy to clean rectangular stainless steel hob with removable pan supports.

- High quality materials and components
- Contemporary, home-like design
- Optimum use of space
- Superior cooking performance

**Technical Specifications**

Product dimensions (WxHxD) : 540x100x445 mm  
 Mounting dimensions (WxD) : 527x429 mm  
 Gas outlet temperature : 5.5 kW  
 Gas type : All gas  
 Hob temperature : 1x2.5 kW 2x1.5 kW  
 Ignition : 12V  
 Hob material : Black glass  
 Hob knobs : Matte nickel  
 Weight : 6 kg









**OVAL DOUBLE COOKER**



**Code** CNFC1348

**Technical Specifications**

Dimensions (WxHxD): 510x80x390 mm  
 Mounting dimensions (WxD) : 460x340 mm  
 Weight : 3.8 kg  
 Burner : 1A-1SR  
 Fuel : Gas

- OPTIONAL  Lighter
- OPTIONAL  Handle
-  Rubber seal
-  Temperature sensor
- STANDARD  LPG 28-30mbar
- STANDARD  Tempered glass







**SQUARE THREE-BURN COOKER**



**Code** CNFC1347

**Technical Specifications**

Dimensions (WxHxD) : 440x80x440 mm  
 Mounting dimensions (WxD) : 400x 400 mm  
 Weight : 5.3 kg  
 Burner : 1A-2SR  
 Fuel : Gas

- OPTIONAL  Lighter
- OPTIONAL  Handle
-  Rubber seal
-  Temperature sensor
- STANDARD  LPG 28-30mbar
- STANDARD  Tempered glass







**RECTANGULAR DOUBLE BUBBLE COOKER**



**Code** CNFC1336

**Technical Specifications**

Dimensions (WxHxD) : 530x110x340 mm  
 Mounting dimensions (WxD) : 515x325 mm  
 Weight : 4.8 kg  
 Burner : 1A-1SR  
 Fuel : Gas

- OPTIONAL  Lighter
- OPTIONAL  Handle
-  Rubber seal
-  Temperature sensor
- STANDARD  LPG 28-30mbar
- STANDARD  Tempered glass







**RECTANGULAR THREE-BURN COOKER WITH SPLIT GLASS LID**



**Code** CNFC1349

**Technical Specifications**

Dimensions (WxHxD) : 716x110x340 mm  
 Mounting dimensions (WxD): 696x324 mm  
 Weight : 5.8 kg  
 Burner : 1A-2SR  
 Fuel : Gas

- OPTIONAL  Lighter
- OPTIONAL  Handle
-  Rubber seal
-  Temperature sensor
- STANDARD  LPG 28-30mbar
- STANDARD  Tempered glass

# COMBINATION COOKERS

## THREE-BURN CORNER COOKER



**Code** CNFC1344  
Left

**Code** CNFC1343  
Right

### Technical Specifications

Dimensions (WxHxD): 480x90x480 mm  
Weight : 5.5 kg  
Burner : 1A-2SR  
Cover : Opens to the left - right  
Fuel : Gas

- |          |  |                    |
|----------|--|--------------------|
| OPTIONAL |  | Lighter            |
|          |  | Handle             |
|          |  | Rubber seal        |
| STANDARD |  | Temperature sensor |
|          |  | LPG 28-30mbar      |
|          |  | Tempered glass     |

## ROUND SINGLE BURN COOKER



**Code** CNFC1345

### Technical Specifications

Dimensions : Ø : 340 mm x D: 80 mm  
Mounting dimensions (WxHxD): Ø : 300 mm  
Weight : 2.1 kg  
Burner : 1SR  
Fuel : Gas

- |          |  |                    |
|----------|--|--------------------|
| OPTIONAL |  | Lighter            |
|          |  | Handle             |
|          |  | Rubber seal        |
| STANDARD |  | Temperature sensor |
|          |  | LPG 28-30mbar      |
|          |  | Tempered glass     |

## SINGLE BURN COMBINATION COOKER



**Code** CNFL1323  
Right

**Code** CNFL1324  
Left

- Single-burner combination stove and sink in one
- Combined glass cover
- Left hob, right sink, folding tap not included
- Water drain and mounting gasket are included

### Technical Specifications

Dimensions (WxHxD) : 530x150x340 mm  
Sink depth : 150 mm  
Weight : 4.5 kg  
Burner : 1SR  
Tap hole : 25 mm  
Fuel : Gas

- |          |  |                    |
|----------|--|--------------------|
| OPTIONAL |  | Lighter            |
|          |  | Handle             |
|          |  | Hot Cold Faucet    |
| STANDARD |  | Temperature sensor |
|          |  | Fixing Kit         |
|          |  | LPG 28-30mbar      |
| OPTIONAL |  | Tempered Glass     |
|          |  | Rubber seal        |
|          |  | Waste Drain        |

## DOUBLE-BURN COMBINATION COOKER



**Code** CNFL1400  
Right

**Code** CNFL1410  
Left

- Double-burner combination stove and sink in one
- Combined glass cover
- Safer with stainless steel hob grill
- You can choose between left hob and right sink, depending on your installation location.
- Folding tap not included
- Water drain and mounting gasket are included

### Technical Specifications

Dimensions (WxHxD) : 716x150x340 mm  
Sink depth : 150 mm  
Weight : 5 kg  
Burner : 1A-1SR  
Tap hole : 25 mm  
Fuel : Gas

- |          |  |                    |
|----------|--|--------------------|
| OPTIONAL |  | Lighter            |
|          |  | Handle             |
|          |  | Hot Cold Faucet    |
| STANDARD |  | Temperature sensor |
|          |  | Fixing Kit         |
|          |  | LPG 28-30mbar      |
| OPTIONAL |  | Tempered Glass     |
|          |  | Rubber seal        |
|          |  | Waste Drain        |

# COMBINATION COOKERS

## DOUBLE COMBINATION COOKER WITH SEPARATED GLASS LID



**Code** CNFL1401

- Double-burner combination stove and sink in one
- Split glass cover
- Safer with stainless steel hob grill
- You can choose between left hob and right sink, depending on your installation location.
- Folding tap not included
- Water drain and mounting gasket are included

### Technical Specifications

Dimensions (WxHxD) : 716x150x340 mm  
 Sink depth : 150 mm  
 Weight : 5 kg  
 Burner : 1A-1SR  
 Tap hole : 25 mm  
 Fuel : Gas

OPTIONAL		Handle	STANDARD		Lighter
		Hot-Cold Faucet			Temperature sensor
		Cold Faucet			Tempered Glass
					Fixing Kit
					Rubber seal
					LPG 28-30mbar
					Waste Drain

## DOUBLE COMBINATION COOKER WITH SEPARATED GLASS LID



**Code** CNFL1402

- Double-burner combination stove and sink in one
- Split glass cover
- Safer with stainless steel hob grill
- You can find left sink and right stove in different options depending on your installation location.
- Folding tap not included
- Water drain and mounting gasket are included

### Technical Specifications

Dimensions (WxHxD) : 716x150x340 mm  
 Sink depth : 150 mm  
 Weight : 5 kg  
 Burner : 1A-1SR  
 Tap hole : 25 mm  
 Fuel : Gas

OPTIONAL		Handle	STANDARD		Lighter
		Hot-Cold Faucet			Temperature sensor
		Cold Faucet			Tempered Glass
					Fixing Kit
					Rubber seal
					LPG 28-30mbar
					Waste Drain

## DOUBLE-BURN COMBINATION COOKER



**Code** CNFL1770

- Double-burner combination stove and sink in one
- Combined glass cover
- You can choose the left stove and right sink according to your installation location.
- Folding tap not included
- Water drain and mounting gasket are included

### Technical Specifications

Dimensions (WxHxD) : 765x100+50x355 mm  
 Mounting dimensions (WxD) : 730x320 mm  
 Sink depth : 150 mm  
 Weight : 6 kg  
 Burner : 1A - 1SR  
 Tap hole : 35mm

**Note:** The right sink and the left stove have glass lids.

OPTIONAL		Handle	STANDARD		Lighter		Tempered Glass
		Hot-Cold Faucet			Temperature sensor		Rubber seal
		Cold Faucet			Fixing Kit		Waste Drain
					LPG 28-30mbar		Faucet Ø 33,5mm

# COMBINATION COOKERS

## DOUBLE-BURN COMBINATION COOKER



**Code** CNFL1780

- Double-burner combination stove and sink in one
- Combined glass cover
- You can choose between the left sink and the right stove depending on your installation location.
- Folding tap not included
- Water drain and mounting gasket are included

### Technical Specifications

Dimensions (WxHxD) : 765x100+50x355 mm  
 Mounting dimensions (WxHxD) : 730x320 mm  
 Sink depth : 150 mm  
 Weight : 6 kg  
 Burner : 1A - 1SR  
 Tap hole : 35mm

**Note:** The left sink and the right stove have glass lids.

OPTIONAL		Handle		Lighter		Tempered Glass
		Hot-Cold Faucet		Temperature sensor		Rubber seal
		Cold Faucet		Fixing Kit		Waste Drain
STANDARD		LPG 28-30mbar		Faucet Ø 33,5mm		

## DOUBLE COMBINATION COOKER WITH SEPARATED GLASS LID



**Code** CNFL1765

- Double-burner combination stove and sink in one
- More comfortable with separate glass cover
- You can choose the left stove and right sink according to your installation location.
- Folding tap not included
- Water drain and mounting gasket are included

### Technical Specifications

Dimensions (WxHxD) : 765x100+50x355 mm  
 Mounting dimensions (WxD) : 730x20 mm  
 Sink depth : 150 mm  
 Weight : 6 kg  
 Burner : 1A - 1SR  
 Tap hole : 35 mm

**Note:** Left hob and right sink with glass lid

OPTIONAL		Handle		Lighter		Tempered Glass
		Hot-Cold Faucet		Temperature sensor		Rubber seal
		Cold Faucet		Fixing Kit		Waste Drain
STANDARD		LPG 28-30mbar		Faucet Ø 33,5mm		

## DOUBLE COMBINATION COOKER WITH SEPARATED GLASS LID



**Code** CNFL1766

- Double-burner combination stove and sink in one
- More comfortable with separate glass cover
- You can choose between the left sink and the right stove depending on your installation location.
- Folding tap not included
- Water drain and mounting gasket are included

### Technical Specifications

Dimensions (WxHxD) : 765x100+50x356 mm  
 Mounting dimensions (WxHxD) : 730x320 mm  
 Sink depth : 150 mm  
 Weight : 6 kg  
 Burner : 1A- 1SR  
 Tap hole : 35mm

**Note:** The left sink and the right stove have glass lids.

OPTIONAL		Handle		Lighter		Tempered Glass
		Hot-Cold Faucet		Temperature sensor		Rubber seal
		Cold Faucet		Fixing Kit		Waste Drain
STANDARD		LPG 28-30mbar		Faucet Ø 33,5mm		



**COMBINATION DOUBLE-BURNED COOKER WITH SEPARATED GLASS LID & ROUND SINK**



**Code** TFSCU11199-SP

Topline 111 is a combination unit specially designed for caravans. The dimensions, and especially the 900 mm width and just 370 mm depth, are optimized for the narrow vehicle kitchen layout, offering the basic functions of two gas burners and a sink.

- High quality materials and components
- Contemporary, home-like design
- Optimal use of space
- Superior cooking performance

**Technical Specifications**

Product dimensions (WxHxD) : 900x195x370 mm  
 Mounting dimensions (WxHxD) (GxD) : 888x358 mm  
 Gas outlet temperature : 3.0 kW  
 Gas type : All gas  
 Hob temperature : 2x1.5 kW  
 Ignition : 12V  
 Hob material : Black glass  
 Hob knobs : Matte nickel  
 Weight : 11 kg  
 Water drain : 25 mm

**Not:** Left hob X right sink

**353 SERIES COMBINATION THREE-BURN COOKER**



<b>Code</b>	TFSCU353099-SP Left sink
<b>Code</b>	TFSCU353199-SP Right Left sink

Thetford's 353 series has successfully combined three burners and a kitchen sink. The 353 series combination stove gives your kitchen a domestic look. Split Glass doors can close individually for extra work space or to streamline the kitchen. Suitable for using larger pots and pans. A single electric ignition makes it easy to ignite the burners, and the whole combination is sturdy and easy to clean.

- High quality materials and components
- Contemporary, home-like design
- Optimal use of space
- Superior cooking performance

**Technical Specifications**

Mounting type : Surface mounted  
 Fuel : All gas  
 Gas burners : 1x1.0 kW 1x1.5 kW 1x 2.4 kW  
 Total heat input (gas) : 4,9 kW  
 Glass cover : Var  
 Hob material : Brushed stainless steel  
 Ignition : 12V  
 Open and close knobs : Matte nickel  
 Net weight : 10.7 kg  
 Product dimensions (GxYxD) : 980x160x410 mm  
 Countertop cutting dimensions (WxD) : 962x389 mm

**Features:** Combination unit with stainless steel chamber (inner chamber 160 mm deep, including water drain Ø 35 mm)

**ROUND GLASS SINK WITH LID**



**Code** TFSBL3051-SP

The quality and ergonomic layout of this series have proven themselves over the years. Stainless steel sinks make cleaning easy. And you can combine them with suitable hobs. Stainless steel round sink with black glass lid suitable for your kitchen.

**Technical Specifications**

Dimensions : Ø : 405 mm Depth : 145 mm  
 Mounting dimensions (WxHxD) : 390 mm  
 Internal dimensions : Ø: 328 mm Depth: 93 mm  
 Filling capacity : 7.4 liters  
 Water drain : 25 mm  
 Sink material : Stainless steel  
 Tap hole : None  
 Weight : 2.4 kg  
 Water expense : Included

**CORNER SINK**



**Code** TFSBL3351-SP **Code** TFSBL3350-SP

The quality and ergonomic layout of this series have proven themselves over the years. Stainless steel sinks make cleaning easy. And you can combine them with compatible hobs. A triangular stainless steel sink that fits perfectly with the Basic Line 330 hob.

- High quality materials and components
- Contemporary, home-like design
- Optimal use of space

**Technical Specifications**

Dimensions (WxHxD) : 480x140x480 mm  
 Mounting dimensions (WxD) : 460x460 mm  
 Depth : Çap: 455 mm  
 Depth : 92 mm  
 Filling capacity : 8.7 liters  
 Water drain : 25 mm  
 Tap hole : 35 mm  
 Sink material : Stainless steel  
 Weight : 2.9 kg  
 Water expense : Included

**SQUARE SINK**



**Code** TFSBL3450-SP

The quality and ergonomic layout of this series have proven themselves over the years. Stainless steel sinks make cleaning easy. And you can combine them with compatible hobs. Rectangular stainless steel sink that fits perfectly on the Basic Line 345 hob

- High quality materials and components
- Contemporary, home-like design
- Optimal use of space

**Technical Specifications**

Dimensions (WxHxD) : 400x140x445 mm  
 Mounting dimensions (WxD) : 387x429 mm  
 Internal dimensions : Ø : 338 mm  
 Depth : 92 mm  
 Filling capacity : 7.5 Liters  
 Su tahliyesi var : 25 mm  
 Tap hole : 35 mm  
 Sink material : Stainless steel  
 Weight : 2.9 kg  
 Water expense : Included

**RECTANGULAR SINK (WITH KITCHEN SET)**



**Code** TFSBL1052-SP



**Code** TFSBL1053-SP

Stainless steel kitchen sink with glass lid.

**Technical Specifications**

Dimensions (WxHxD) : 360x153x470 mm  
 Mounting dimensions (WxD) : 335x430 mm  
 Internal dimensions : Ø : 368 mm  
 Depth : 99 mm  
 Filling capacity : 9.5 Liters  
 Water drain : 19 mm  
 Tap hole : Yok  
 Sink material : Stainless steel  
 Weight : 3.2 kg

**Note:** Kitchen set is optional.

**RECTANGULAR SINK**



**Code** TFSSK1054-SP



**Code** TFSSK1055-SP

**Technical Specifications**

Dimensions (WxHxD) : 630x152x470 mm  
 Mounting dimensions (WxD) : 605x415 mm  
 Internal dimensions : Ø: 368 mm  
 Depth: 99 mm  
 Filling capacity : 9.5 liters  
 Water drain : 19 mm  
 Tap hole : Yok  
 Sink material : Stainless steel  
 Weight : 4.8 kg  
 Water expense : Included

**OVAL SINK**



**Code** CNLR1450

**Technical Specifications**

Dimensions (WxHxD) : 460x160x340 mm  
 Mounting dimensions (WxD) : 460x340 mm  
 Filling capacity : 6 liters  
 Sink material : Stainless steel  
 Faucet : Yes (cold) chrome  
 Weight : 4.5 kg

- OPTIONAL**
  - Hot-Cold Faucet
  - Rubber seal
  - Waste Drain
- STANDARD**
  - Tempered glass
  - Cold Faucet

**OVAL SINK**



**Code** CNLR1751

**Technical Specifications**

Dimensions : Ø: 300 mm  
 Depth: 180 mm  
 Mounting dimensions (WxD) : 305 mm  
 Filling capacity : 6 liters  
 Sink material : Stainless steel  
 Faucet : Yes (cold) chrome  
 Weight : 4.5 kg

- OPTIONAL**
  - Hot-Cold Faucet
  - Rubber seal
  - Waste Drain
- STANDARD**
  - Tempered glass
  - Cold Faucet

**SQUARE SINK**



**Code** CNLR1760

**Technical Specifications**

Dimensions (WxHxD) : 320x150x350 mm  
 Mounting dimensions (WxD) : 305x335 mm  
 Filling capacity : 9 liters  
 Sink material : Stainless steel  
 Faucet : Hot or Cold  
 Weight : 4.5 kg

- OPTIONAL**
  - Hot-Cold Faucet
  - Rubber seal
  - Waste Drain
- STANDARD**
  - Tempered glass
  - Cold Faucet

**CAPRI CHROME FAUCET**



**Code** CM2651.20.21

**Technical Specifications**

Hot and Cold Faucet  
 Part features : Foldable from outside  
 Height : 160 mm  
 Faucet length : 160 mm  
 Mounting hole diameter : 45 mm  
 Connection inner hose : 10 mm

**MODENA STANDARD CHROME FAUCET**



**Code** CM2451.20.21

**Technical Specifications**

Hot and Cold Faucet  
 Part features : Can be rotated from outside  
 Height : 230 mm  
 Faucet length : 95 mm  
 Mounting hole diameter : 33 mm  
 Connection inner hose : 10 mm  
 Cord length : 40 mm

**MODENA COMPACT CHROME FAUCET**



**Code** CM2455.20.21

**Technical Specifications**

Hot and Cold Faucet  
 Part features : Can be rotated from outside  
 Height : 190 mm  
 Faucet length : 95 mm  
 Mounting hole diameter : 33 mm  
 Connection inner hose : 10 mm  
 Cord length : 40 mm

**MODENA STANDART CHROME BIO FAUCET**



**Code** CM2451.47.21

**Technical Specifications**

Hot and Cold Faucet  
 Part features : Can be rotated from outside  
 Height : 230 mm  
 Faucet length : 95 mm  
 Mounting hole diameter : 33 mm  
 Connection inner hose : 10 mm  
 Cord length : 40 mm

**MODENA CHROME WALL FAUCET**



**Code** CM2091.20.21\_U

**Technical Specifications**

Hot and Cold Faucet  
 Part features : Can be rotated from outside  
 Height : 240 mm  
 Faucet length : 80 mm  
 Mounting depth : 95 mm  
 Mounting dimensions (WxD) : 60x200 mm  
 Connection inner hose : 8/10 mm  
 Cord length : 350 mm

**ROMA LONDON CHROME FAUCET**



**Code** CM2737.20.21

**Technical Specifications**

Hot and Cold Faucet  
 Part features : Can be rotated from outside  
 Height : 125 mm  
 Faucet length : 80 mm  
 Mounting depth : 95 mm  
 Mounting dimensions (WxD) : 60x200 mm  
 Connection inner hose : 8/10 mm  
 Cord length : 350 mm

**PARMA STANDARD 40° FAUCET**



**Code** CM2811.20.21

**Technical Specifications**

Hot and Cold Faucet  
 Part features : Rotatable tap  
 Height : 120 mm  
 Faucet length : 170 mm  
 Mounting hole : 33 mm  
 Connection inner hose : 10 mm  
 Cord length : 30 mm

**PARMA LANGER AUSLAUF CHROME FAUCET**



**Code** CM2803.20.21

**Technical Specifications**

Hot and Cold Faucet  
 Part features : Rotatable tap  
 Height : 170 mm  
 Faucet length : 220 mm  
 Mounting hole : 33 mm  
 Connection inner hose : 10 mm  
 Cord length : 30 mm

### STANDARD CHROME FAUCET



**Code** CM2851.20.21

#### Technical Specifications

Hot and Cold Faucet  
 Part features : Rotatable tap  
 Height : 130 mm  
 Faucet length : 170 mm  
 Mounting depth : 33 mm  
 Connection inner hose : 10 mm  
 Cord length : 30 mm

### FLORENZ CHROME FOLDING FAUCET



**Code** CM2393.20.21

#### Technical Specifications

Hot and Cold Faucet  
 Part features : Foldable tap  
 Height : 85 mm  
 Faucet length : 150 mm  
 Mounting depth : 33 mm  
 Connection inner hose : 10 mm  
 Cord length : 35 mm

### LONDON STANDARD CHROME FAUCET



**Code** CM2203.22.21

#### Technical Specifications

Hot and Cold Faucet  
 Part features : Foldable tap  
 Height : 40 mm  
 Faucet length : 145 mm  
 Width : 87 mm  
 Mounting diameter : 22 mm

### FLORENZ COMPACT FOLDING FAUCET



**Code** CM2351.20.21

#### Technical Specifications

Hot and Cold Faucet  
 Renk : Chrome plastic  
 Part features : Folds from outside  
 Height : 40 mm  
 Faucet length : 140 mm  
 Width : 80 mm  
 Mounting diameter: 33 mm

### LONDON FOLDABLE FAUCET



**Code** CM2201.70.21

#### Technical Specifications

Hot and Cold Faucet  
 Color : White plastic  
 Part features : Folds from outside  
 Height : 40 mm  
 Faucet length : 145 mm  
 Width : 87 mm  
 Mounting diameter: 27mm

### CHROME FAUCET



**Code** CM4696.30.68

#### Technical Specifications

Spiral hot - cold tap  
 Color : Chrome  
 Height : 175 mm  
 Width : 50 mm  
 Mounting diameter: 32 mm  
 Spiral hose : 250 mm

**LUCCA CHROME FAUCET**



**Code** CM2471.20.21

**Technical Specifications**

Hot and Cold Faucet  
Part features : 360° rotatable  
Height : 305mm  
Width : 94mm  
Cord length : 160mm

**FLORENZ DESIGN SIENNA FOLDABLE FAUCET**



**Code** CM2395.20.81

**Technical Specifications**

Hot and Cold Faucet  
Faucet length : 120mm  
Height : 40mm (folded down)  
Mounting hole diameter : 33mm  
Connection inner hose : 10mm

**FLORENZ DESIGN PARMA LONG FOLDABLE FAUCET**



**Code** CM2389.20.61

**Technical Specifications**

Hot and Cold Faucet  
Faucet length : 220mm  
Height : 40mm (folded down)  
Mounting hole diameter : 33mm  
Connection inner hose : 10mm

**SIENNA FLORENZ FOLDABLE FAUCET**



**Code** CM2393.20.81

**Technical Specifications**

Hot and Cold Faucet  
Faucet length : 150mm  
Mounting hole diameter : 33mm  
Connection inner hose : 10mm  
Height : 40mm (folded down)

**ROMA FLORENZ CHROME FAUCET**



**Code** CM2381.20.21

**Technical Specifications**

Hot and Cold Faucet  
Height : 40mm (folded down)  
Faucet length : 140mm  
Mounting hole diameter : 33mm  
Connection inner hose : 10mm

**ROMA STANDARD 30° CHROME FAUCET**



**Code** CM2751.20.21

**Technical Specifications**

Hot and Cold Faucet  
Part features : Rotatable outlet  
Height : 125mm  
Faucet length : 150mm  
Mounting hole diameter : 33mm

**ROMA 40° CHROME FAUCET**



**Code** CM2773.20.21

**Technical Specifications**

Hot and Cold Faucet  
Part features : Rotatable outlet  
Height : 125mm  
Mounting hole diameter : 33mm  
Faucet length : 170mm

**NIZZA CHROME FAUCET**



**Code** CM4111.30.21

**Technical Specifications**

Hot and Cold Faucet  
Height : 170 mm  
Diameter : maks. 45 mm  
Mounting diameter : 34 mm



## BATHROOM - TOILET

---

TOILET CARE  
CASSETTE TOILETS  
PORTABLE TOILETS  
FAUCETS  
WATER DRAINS





**AQUA KEM® BLUE**



**Code** TF30112AT

Aqua Kem Blue is a very powerful and easy-to-use toilet liquid for the waste tank. It is very effective for portable and cassette toilets.

**Thetford Aqua Kem Blue is the #1 toilet fluid for mobile toilets worldwide!**

**Benefits**

- 1 dose is sufficient for up to 5 days
- 2 liters = 13 doses (150 ml)
- Excellent masking of unpleasant odors
- Liquefies solid components so tank is easy to empty
- Reduces gas formation
- 2 liter bottles available

**POWERPODS BLUE**



**Code** TF30751XX

PowerPods deliver cutting-edge appearance and performance, representing the next generation of convenient single-dose waste holding tank additives. Thanks to the innovative perfume lock technology, the scent is kept in the compartments until needed, so there is almost no odor left in your bathroom and on your hands. PowerPods deliver exceptional performance by representing the power of Thetford additives in one capsule!

**Benefits**

- The right dose every time.
- Liquefies waste for easier tank emptying.
- Reduces gas formation.
- 1 dose lasts up to 5 days.
- 1 box of bags = 20 compartments = 100 days of trouble-free use of your waste holding tank.
- Highly concentrated 24.5 ml Capsule
- Leaves a pleasant, fresh scent

**POWERPODS BIO**



**Code** TF30756XX

PowerPods deliver cutting-edge appearance and performance, representing the next generation of convenient single-dose waste holding tank additives. Thanks to the innovative perfume lock technology, the scent is kept in the compartments until needed, so there is almost no odor left in your bathroom and on your hands. PowerPods deliver exceptional performance by representing the power of Thetford additives in one capsule!

**Benefits**

- Convenient pre-dosed capsule for maximum ease of use.
- Liquefies waste for easier tank emptying.
- Septic tank casing.
- 1 dose lasts up to 4 days.
- Ecofriendly.
- Innovative microbiological technology.
- 1 box of bags = 20 compartments = 80 days of trouble-free use of your waste holding tank.
- Highly concentrated 24.5 ml Capsule

**AQUA KEM® BLUE  
CONCENTRATED**



**Code** TF30621CX

It is a very effective, double concentrated toilet liquid for the waste tank of a portable or cassette toilet.

**Benefits**

- Turns the waste into liquid so the tank can be emptied more easily
- Reduces gas formation
- Fragrance and number of doses equal to Aqua Kem Blue Original (13 doses, 65 days)
- Excellent masking of unpleasant odors
- Only 60 ml dose is required in the new concentrate model instead of 150 ml used in Aqua Kem Blue Original 2 liters
- Less weight (800 grams of Aqua Kem Blue Concentrate has become more useful instead of 2.2 kg of Aqua Kem Blue 2 liters)

**AQUA KEM® BLUE  
LAVENDER CONCENTRATED**



**Code** TF30627CX

It is a very effective, double concentrated toilet liquid for the waste tank of a portable or cassette toilet.

**Benefits**

- Nice smell
- The waste becomes liquid so the tank can be emptied more easily
- Reduces gas formation
- Number of doses and scents equal to Aqua Kem Blue Lavender (13 doses, 65 days)
- Excellent masking of unpleasant odors
- Only 60 ml dose required instead of 150 ml Aqua Kem Blue Original
- Less weight (800 grams of Aqua Kem Blue Lavender Concentrate is in a bottle from 2.2 kg of Aqua Kem Blue 2 liters)
- Convenient bottle

**AQUA KEM BLUE CONCENTRATED  
EUCALYPTUS**



**Code** TF30761CX

Aqua Kem Blue Concentrate Eucalyptus is one of the newest members of Thetford's well-known Concentrate family. Aqua Kem® Blue Concentrated Eucalyptus leaves a unique scent in your caravan.

**Benefits**

- Attractive eucalyptus scent with a touch of mint
- 1 dose lasts up to 5 days
- Convenient small bottle, less weight (compared to Aqua Kem® Blue 2 litres)
- Significantly improved waste liquefaction for easier tank emptying
- Significantly improved reduction in gas formation

**AQUA KEM® GREEN  
CONCENTRATED**



**Code** TF30645CX

It is a very effective, environmentally friendly, double concentrated green toilet liquid for the waste tank of a portable or cassette toilet.

**0.75L AQUA KEM® GREEN CONCENTRATE = 1.5L AQUA KEM® GREEN**

- Convenient, smaller and lighter bottle
- Less plastic, less bad for the environment
- Suitable for draining in septic tanks (anaerobic biodegradation test from Thetford)
- 1 dose of 75 ml is sufficient for 4 days.
- 1 bottle = 10 doses, which gives you 40 days of worry-free use of your waste tank.

**Developed!**

- Compared to original Aqua Kem Green
- The waste becomes more fluid, making it easier to empty the tank
- Significantly less gas formation
- A cleaner waste tank



### CASSETTE TANK CLEANER



**Code** TF30311AK

It is an effective liquid for periodic cleaning and maintenance. Cassette Tank cleaner cleans stubborn lime residues that may form on the moving parts and surfaces of the waste tank. There is no need for brushing..

**Benefits**

- 1 liter = 3 doses
- Waste tank always stays new, shiny and clean
- Extends the service life of the waste tank
- No scrubbing required
- Easiest way to clean residues
- Leaves a pleasant, fresh scent
- Use 2 to 3 times a year for optimum results
- Available in 1 liter bottle

### TANK FRESHENER



**Code** TF30272DA

It prevents bad odors by renewing your toilet tank. It extends the usage time of the tank.

**Benefits**

- 1.5 liters
- Reduces sediment and regenerates the waste tank
- Prevents bad bad formation
- Provides trouble-free tank emptying

**DUO TANK CLEANER  
CONCENTRATED 800 ml**



**Code** TF30771AK

Duo Concentrate Tank Cleaner is one of the newest members of Thetford's well-known concentrate family.

**Benefits**

- It is an ideal product to keep both tanks clean and fresh for a long time.
- Extends the life of tanks
- Removes limescale, sediment and other deposits
- Provides cleaning without damaging the parts inside the tanks
- For best results, it is recommended to use 2-3 times a year

**AQUA RINSE CONCENTRATED**



**Code** TF30651CX

A very strong double concentrated liquid that emits a pleasant scent for your cassette and portable toilets.

**0.75L AQUA RINSE CONCENTRATE = 1.5L  
AQUA RINSE PLUS**

- Convenient, smaller and lighter bottle
- Less plastic, less bad for the environment
- Suitable for discharge into septic tanks (anaerobic biodegradation test from Thetford)
- Suitable for both plastic and ceramic toilets!
- 1 bottle = 15 doses, each suitable for 15 liters of clean rinse water!

**Advantages**

- Prevents limescale formation in your washing water tank
- Provides long-lasting shiny toilet bowl
- Provides more efficient and equal rinsing
- Fresh lavender scent after each rinse

**GREY WATER FRESH  
CONCENTRATED**



**Code** TF30700AK

It is a strong and effective concentrated liquid that prevents bad odors from spreading inside the vehicle.

**Benefits**

- Reduces deposits in the gray water tank.
- It prevents odors spreading inside the vehicle.
- Keeps gray water clean and fresh for longer.
- It prevents unpleasant odors when emptying the gray water tank.
- 780ml compact bottle.

**BATHROOM CLEANER**



**Code** TF20566AK

Foam spray specially developed for easy, safe and thorough cleaning of all plastic surfaces in and around the bathroom.

**Benefits**

- Powerful active foam removes stubborn dirt and limescale
  - Ideal cleaning product for daily use
  - Provides a fresh scent
  - For perfect hygienic cleanliness and brilliant shine!
  - Available in a 500 ml bottle
- Tip: Wipe with a soft, dry cloth for a beautiful, shiny result

**TOILET BOWL CLEANER**



**Code** TF30337AK

Toilet bowl cleaner. Used for ultra-clean toilets and optimum hygiene.

**Benefits**

- Limescale remover
- Protects plastic, ceramic and toilet seals
- Thick, concentrated formula
- A hygienic and clean toilet
- Available in 750 ml Compact bottle

**AQUA RINSE SPRAY**



**Code** TF30216AK

Aqua Rinse Spray is a spray for toilets connected directly to the central water tank.

**Benefits**

- It creates a protective layer in the toilet bowl and provides effective washing.
- Saves water because less washing is required
- Provides a long-lasting, fresh scent
- Suitable for emptying in septic tanks
- Available in a 500 ml spray bottle

(Test ISO 11734)

**SEAL LUBRICANT**



**Code** TF30003ED

For use on toilet lids, locks, hinges, awning rails, bicycles, etc. A lubricant for periodic maintenance, protection and lubrication. Thetford Seal Lubricant has been specially developed for our toilets and can be used completely safely.

**Benefits**

- Protects toilet seals from drying out
- Ensures trouble-free operation of Thetford toilet
- Spray almost anything to prevent squeaks, cracks or leaks
- Can be used safely on plastic and rubber
- Coated in a single thin layer
- Available in 200 ml spray can

**AQUA SOFT**



**Code** TF202240

Super soft toilet paper that dissolves quickly. Prevents clogging and waste. It makes emptying the tank easier.

**Benefits**

- Makes it easier to empty the waste tank
- Helps prevent waste tank clogging or damage
- Specially developed for chemical toilets
- Awarded with the prestigious Nordic Swan
- Available in packages of 4 rolls

**CASSETTE TOILET  
C223-S**



**Code** TF200850

- Thetford has presented the new C223-S model with its aesthetic appearance to users who have space problems. He managed to solve this problem by removing the rear casing of the toilet from the system and mounting the control panel on the wall.
- The seat of the toilet has a 90° rotating feature.
- You do not have to increase the waste tank cassette capacity and carry the cassette at the same time, it can now be transported more easily with the designed wheel system and pulling handle.
- Modern flush usage thanks to the electric button
- Level indicator for waste holding tank

**Technical Specifications**

Dimensions (WxHxD) : 365x495x580 mm  
 Seating height : 492 mm  
 Waste tank capacity : 18 litre  
 Weight : 6.8 kg  
 Energy : 12 V  
 Level indicator : Waste holding tank

**CASSETTE TOILET  
C223-CS**



**Code** TF200851

- Thetford presented its new model to its users with its aesthetic appearance.
- The seat of the toilet has a 90° rotating feature.
- You do not have to increase the waste tank cassette capacity and carry the cassette at the same time, it can be carried more easily with the wheel system and pulling handle.
- Highest level of seating comfort on the market
- Quiet yet powerful washing system with full bowl coverage
- Modern flush usage thanks to the electric button
- Waste holding tank with level indicator

**Technical Specifications**

Dimensions (WxHxD) : 394x534x580 mm  
 Seating height : 492 mm  
 Waste tank capacity : 18 litre  
 Weight : 7.2 kg  
 Energy : 12 V  
 Level indicator : Waste holding tank

**CASSETTE TOILET  
C224-CW**



**Code** TF200869SP

- Thetford presented its new model to its users with its aesthetic appearance.
- The seat of the toilet has a 90° rotating feature.
- You do not have to increase the waste tank cassette capacity and carry the cassette at the same time, it can be carried more easily with the wheel system and pulling handle.
- Highest level of seating comfort on the market
- Quiet yet powerful washing system with full bowl coverage
- Level indicator for waste holding tank

**Technical Specifications**

Dimensions (WxHxD) : 417x750x600 mm  
 Seating height : 492 mm  
 Clean water tank capacity : 9 liters / manual water filling  
 Waste tank capacity : 18 liters  
 Weight : 7.2 kg  
 Level indicator : Waste holding tank

**CASSETTE TOILET  
C262-CWE**



<b>Code</b>	TF93367SP
<b>Code</b>	TF93388SP CERAMIC

- Highest level of seating comfort on the market.
- Easy and convenient cleaning.
- Quiet yet powerful washing system with full bowl coverage
- Modern flush usage thanks to the electric button
- 3-level indicator for waste holding tank

**Technical Specifications**

Dimensions (WxHxD)	: 417x750x603 mm
Seating height (Plastic)	: 492 mm
Seating height (Ceramic)	: 479 mm
Clean water tank capacity	: 8 liters
Waste tank capacity	: 17.5 liters
Weight (Plastic)	: 8.1 kg
Weight (Ceramic)	: 17.2 kg
Energy	: 12 V
Level indicator	: 3 seviyeli Waste holding tank

**CASSETTE TOILET  
C263-S**



<b>Code</b>	TF93379SP
<b>Code</b>	TF93386SP CERAMIC

- Highest level of seating comfort on the market
- Easy and convenient cleaning
- Quiet yet powerful washing system with full bowl coverage
- Modern flush usage thanks to the electric button
- 3-level indicator for waste holding tank

**Technical Specifications**

Dimensions (WxHxD)	: 341x488x600 mm
Seating height (Plastic)	: 467 mm
Seating height (Ceramic)	: 479 mm
Waste tank capacity	: 17.5 liters
Weight (Plastic)	: 7.1 kg
Weight (Ceramic)	: 16,2
Energy	: 12 V
Level indicator	: 3-level waste holding tank

**CASSETTE TOILET  
C263-CS**



<b>Code</b>	TF93385SP
<b>Code</b>	TF93387SP CERAMIC

- The seat of the toilet has a 90° rotating feature.
- You do not have to increase the waste tank cassette capacity and carry the cassette at the same time, it can be carried more easily with the wheel system and pulling handle.
- Highest level of seating comfort on the market
- Quiet yet powerful washing system with full bowl coverage
- Modern flush usage thanks to the electric button
- 3-level indicator for waste holding tank

**Technical Specifications**

Dimensions (WxHxD)	: 417x750x603 mm
Seating height (Plastic)	: 467 mm
Seating height (Ceramic)	: 497 mm
Waste tank capacity	: 17.5 liters
Weight (Plastic)	: 8,0 kg
Weight (Ceramic)	: 17.1 kg
Energy	: 12 V
Level indicator	: 3-level waste holding tank

**CASSETTE TOILET C402X**



<b>Code</b>	TF51677SP LEFT CASSETTE	<b>Code</b>	TF51676SP RIGHT CASSETTE
-------------	----------------------------	-------------	-----------------------------

- Highest level of seating comfort on the market.
- Lightweight, high quality, durable.
- Quiet but powerful washing system with full coverage.
- Easy and convenient cleaning.
- Modern flush usage thanks to the electric button
- 3-level display for wash water tank
- 3-level indicator for waste holding tank

**Technical Specifications**

Dimensions (WxHxD) : 670x512x400 mm  
 Seating height : 473 mm  
 Clean water tank capacity: 15 litre  
 Waste tank capacity : 19,3 liters  
 Weight : 8.8 kg  
 Energy : 12 V  
 Level indicator : 3-level waste and clean water tank

**CASSETTE TOILET C403L**



<b>Code</b>	TF51679SP LEFT CASSETTE	<b>Code</b>	TF51678SP RIGHT CASSETTE
-------------	----------------------------	-------------	-----------------------------

- Highest level of seating comfort on the market
- Lightweight, high quality, durable
- Quiet but powerful washing system with full coverage
- Easy and convenient cleaning
- Modern flush usage thanks to the electric button
- 3-level indicator for waste holding tank

**Technical Specifications**

Dimensions (WxHxD) : 670x512x400 mm  
 Seating height : 473 mm  
 Waste tank capacity : 19,3 liters  
 Weight : 8.1 kg  
 Energy : 12 V  
 Level indicator : 3-level waste holding tank





**TOILET FRESH-UP SET C200**



**Code** TF2334062

**TOILET FRESH-UP SET C234**



<b>Code</b>	TF20057062 LEFT
<b>Code</b>	TF20057162 RIGHT

It's an easy and economical way to restore a used cassette toilet to new. Additional waste storage for long journeys.

**TOILET FRESH-UP SET C250-260**



**Code** TF9339362

**TOILET FRESH-UP SET C400**



**Code** TF5169062

It's an easy and economical way to restore a used cassette toilet to new. Additional waste storage for long journeys.

**PORTABLE TOILET  
PORTA POTTI 365**



**Code** TF92820

Designed for use in camping, caravans, boats and long trips. High-quality portable toilets, made of hygienic materials that are best in class and easy to clean, are offered to their users.

**Technical Specifications**

Dimensions (WxHxD) : 383x414x427 mm  
 Seating height : 408mm  
 Clean water tank capacity : 15 liters  
 Waste tank capacity : 21 liters  
 Weight : 4 kg  
 Washing system : Piston pump  
 Level indicator : Waste water tank

**PORTABLE TOILET  
PORTA POTTI 565 P - 565 E**



**Code** TF92305  
Manual (565P)

**Code** TF92306  
Electric (565 E)

Designed for use in camping, caravans, boats and long trips. High-quality portable toilets, made of hygienic materials that are best in class and easy to clean, are offered to their users.

**Technical Specifications**

Dimensions (WxHxD) : 388x448x450 mm  
 Seating height : 443 mm  
 Clean water tank capacity : 15 liters  
 Waste tank capacity : 21 liters  
 Weight (manual model) : 5.3 kg  
 Weight (12V model) : 5.5 kg  
 Washing system (manual) : Piston pump  
 Washing system (12V model): Electric  
 Level indicator : Waste and clean water tank



Porta Potti 565 P



Porta Potti 565 E



Fresh water tank level indicator



Integrated toilet paper holder

**PORTABLE TOILET  
PORTA POTTI 145**



**Code** TF92802

Designed for use in camping, caravans, boats and long trips. High-quality portable toilets, made of hygienic materials that are best in class and easy to clean, are offered to their users.

**Technical Specifications**

Dimensions (WxHxD) : 383x330x427 mm  
 Seating height : 324 mm  
 Clean water tank capacity : 15 liters  
 Waste tank capacity : 12 liters  
 Weight : 3.6 kg  
 Washing system : Bellows pump

**PORTABLE TOILET  
PORTA POTTI 165**



**Code** TF92806

Designed for use in camping, caravans, boats and long trips. High-quality portable toilets, made of hygienic materials that are best in class and easy to clean, are offered to their users.

**Technical Specifications**

Boyutlar (GxYxD) : 383x414x427 mm  
 Seating height : 324 mm  
 Clean water tank capacity : 15 liters  
 Waste tank capacity : 21 liters  
 Weight : 3.9 kg  
 Washing system : Bellows pump

**PORTABLE TOILET  
PORTA POTTI 335**



**Code** TF92828

Designed for use in camping, caravans, boats and long trips. High-quality portable toilets, made of hygienic materials that are best in class and easy to clean, are offered to their users.

**Technical Specifications**

Dimensions (WxHxD) : 342x313x382 mm  
 Seating height : 324 mm  
 Clean water tank capacity : 10 liters  
 Waste tank capacity : 10 liters  
 Weight : 3.3 kg  
 Washing system : Piston pump  
 Level indicator : Waste water tank

**PORTABLE TOILET  
PORTA POTTI 345**



**Code** TF92814

Designed for use in camping, caravans, boats and long trips. High-quality portable toilets, made of hygienic materials that are best in class and easy to clean, are offered to their users.

**Technical Specifications**

Dimensions (WxHxD) : 342x313x382 mm  
 Seating height : 324 mm  
 Clean water tank capacity : 15 liters  
 Waste tank capacity : 12 liters  
 Weight : 3.8 kg  
 Washing system : Piston pump  
 Level indicator : Waste water tank

## SPIRAL TRIGGER CHROME TAP



**Code** CM2815.20.21

Hot - cold tap  
12 V  
1500 mm shower spiral length  
Mounting diameter : 33 mm  
Faucet length : 150 mm  
Height : 110 mm  
Color : Krom

## FOLDABLE TAP WITH MIXER



**Code** CM2413.43.21

Triggered chrome tap with hot - cold folding mixer shower head  
12 V  
Mounting diameter : 27 mm  
Faucet length : 150 mm  
Height : 170 mm

## FOLDABLE THIN PLASTIC TAP



**Code** CM2511.06.21

Cold tap  
12 V  
Color : White  
Mounting diameter : 17 mm  
Faucet length : 120 mm  
Width : 70 mm / 45 mm  
(aşağı katlanmış)  
Height : 145 mm / 38 mm  
(aşağı katlanmış)

## ARONA BLACK CHROME TAP



**Code** CM2431.22.21

Hot and cold tap  
Part features : Foldable tap  
Width : 100 mm  
Height : 130 mm  
Depth : 55 mm  
Faucet length : 160 mm  
Mounting diameter : 27 mm

## FOLDABLE PLASTIC TAP



**Code** CM2256.06.21

Cold folding tap  
12 V  
Mounting diameter : 27 mm  
Faucet length : 220 mm  
Color : White

## MIXER TAP



**Code** CM2559.43.69

Triggered shower head with hot and cold mixer  
12 V  
Mounting diameter : 40 mm  
Faucet length : 140 mm  
Height : 130 mm

## FOLDABLE THIN PLASTIC TAP



**Code** CM2515.06.21

Hot - cold tap  
12 V  
Color : White  
Mounting diameter : 17 mm  
Faucet length : 120 mm  
Width : 126 mm / 45 mm  
(folded down)  
Height : 185 mm / 38 mm  
(folded down)

## FOLDABLE THIN PLASTIC TAP



**Code** CM2115.22.21

Hot - cold tap  
12 V  
Color : Chrome  
Mounting diameter : 17 mm  
Faucet length : 120 mm  
Width : 126 mm / 45 mm  
(folded down)  
Height : 185 mm / 32 mm  
(folded down)

## BATHROOM SPIRAL WALL TAP



**Code** CM2031.20.21\_U

Hot - cold tap  
12 V  
1500 mm shower spiral length  
165 mm tap outlet  
Dimensions : 80x240 mm  
Kurulum derinliği : 95 mm  
Mounting type : Vertical

## BATHROOM SPIRAL WALL TAP



**Code** CM2075.20.21\_L

Hot - cold tap  
12V  
1500 mm shower spiral length  
Installation depth : 95 mm  
Mounting type : Horizontal

## BATHROOM SPIRAL WALL TAP



**Code** CM2077.20.21\_U

Hot - cold tap  
12 V  
1500 mm shower spiral length  
145 mm tap outlet  
Dimensions : 80x240 mm  
Installation depth : 95 mm  
Mounting type : Vertical

## SPIRAL SHOWER TAP



**Code** CM2643.20.21

Hot - cold tap  
12V  
1500 mm shower spiral length  
Mounting diameter : 33 mm  
Height : 140 mm

## SPIRAL CHROME TAP



**Code** CM4660.30.68

Hot - cold tap  
1500 mm shower spiral length  
Mounting diameter: 32 mm  
165 mm tap outlet

## SPIRAL TRIGGER CHROME TAP



**Code** CM4695.30.68

Hot - cold tap  
1500 mm shower spiral length  
165 mm tap outlet  
Mounting diameter : 32 mm

## SHOWER ACCESSORIES

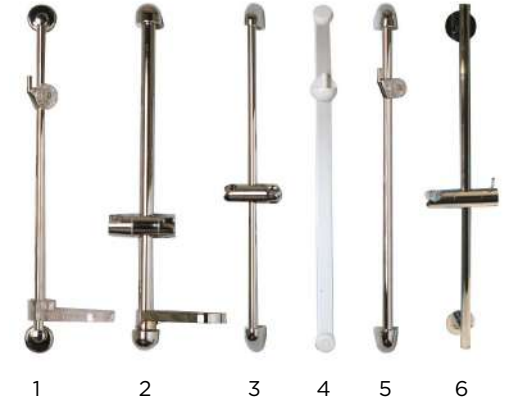

<b>Code</b> 1	CM3022.30.00
Soap dispenser and shower phone holder transparent	

<b>Code</b> 2	CM3022.30.01
Soap dish and shower phone holder chrome	

<b>Code</b> 3	CM3022.30.02
Chrome shower phone holder	

<b>Code</b> 4	CM3700.30.00
Towel holder	

<b>Code</b> 5	CM3022.70.00
Hand shower holder white chrome	

<b>Code</b> 6	CM3028.30.00
shower phone holder chrome	

**ROMAN CHROME TAP**



**Code** CM2727.20.21

Hot - cold tap  
 Part features : Foldable tap  
 Height : 125mm  
 Faucet length : 1500mm  
 Mounting hole diameter : 33mm  
 Faucet diameter : 50mm

**CUBE CHROME CAST STAINLESS TAP**



**Code** CM4750.30.21

Hot - cold tap  
 Height : 275mm / 125mm  
 Faucet length : 250mm  
 Mounting hole diameter : 35mm

**PARMA SLIDING HAND SHOWER**



**Code** CM2811.20.21

Hot - cold tap  
 Height : 110mm  
 Diameter : 50mm  
 Mounting hole diameter : 33mm  
 Faucet length : 1500mm

**NOVO COMBINATION SHOWER TAP**



**Code** CM3215.20.00

Hot and cold tap  
 Height : 190mm  
 Mounting hole diameter : 34mm

**COMPACT WALL TAP**



**Code** CM2069.20.21\_U

Hot - cold tap  
 Connection : Nylon flexible hoses  
 45° 350 mm, 8/10 mm  
 Dimension : 240x80mm  
 Depth : 95 mm  
 Mounting hole : 200x60mm



## ABS CORNER BATHROOM SINK



**Code** CM8705.06.00

### Technical Specifications

Cutting size : 340x165 mm  
 Corner lengths : 354x345 mm  
 Sink depth : 120 mm

## ABS LONG CORNER BATHROOM SINK



**Code** CM8710.06.00

### Technical Specifications

Cutting size : 425x265 mm  
 External dimension: 840x375 mm  
 Depth : 160 mm

## ABS CORNER BATHROOM SINK



**Code** CM8706.06.00

### Technical Specifications

Cutting size : 430x270mm  
 Corner lengths : 420x420 mm  
 Sink depth : 170 mm

## ABS LONG CORNER BATHROOM SINK



**Code** CM8711.06.00

### Technical Specifications

Cutting size : 425x265 mm  
 External dimension: 840x375 mm  
 Depth : 160 mm

## ABS BATHROOM SINK



**Code** CM8707.06.00

### Technical Specifications

Cutting size : 385x205mm  
 Corner lengths : 450x435 mm  
 Sink depth : 150 mm

## ABS LONG SINK



**Code** CM8712.06.00

### Technical Specifications

Cutting size : 425x265 mm  
 External dimension: 840x375 mm  
 Depth : 160 mm

## ABS FOLDABLE BATHROOM SINK



**Code** CM8720.06.00

### Technical Specifications

Wall bracket (WxHxD) : 540x180x105 mm  
 Folded size (WxHxD) : 540x315x175 mm

## ABS LONG ROUND SINK



**Code** CM8713.06.0011

### Technical Specifications

Dimensions (WxHxD): 900x140x340 mm  
 Cutting size: 290 mm Ø  
 Sink depth: 270 mm



## THETFORD C260 SERIES TOILET FAN

**THETFORD**



**Code** TF93417

The electric fan C260 automatically filters odors from the waste holding tank out of the vehicle in an odorless manner.

- Superior quality
- Practical use
- Long durability

### Technical Specifications

Operating power : 12V

## COMET FAN



**Code** CM5252.02.00

It is the most suitable fan to use for air evacuation in bathrooms, kitchens and above beds.

### Technical Specifications

Roof hole : 95 mm  
 Consumption : 7 W  
 Operating power : 12 V  
 Roof thickness : 25-30 mm  
 Roof top height : 75 mm  
 Head diameter : 200 mm

## COMET HIGH FAN



**Code** CM5261.02.00

It is the most suitable fan to use for air evacuation above bathrooms and kitchens.

### Technical Specifications

Roof hole : 80 mm  
 Consumption : 7 W  
 Operating power : 12 V  
 Roof top height : 225 mm

## COMET WALL FAN



**Code** CM5240.02.00

### Technical Specifications

Mounting hole : 80 mm  
 Consumption : 7 W  
 Operating power : 12 V  
 Mounting depth : 120 mm



**Code** CM5220.05.00

### Technical Specifications

Outlet diameter : 80x80 mm  
 Consumption : 4-6 W  
 Operating power : 12 V  
 Operating temperature: maks. 85°C  
 Width : 112 mm

# WATER SYSTEMS

---

- WATER PUMPS
- SUBMERSIBLE PUMPS
- PRESSURE BALANCER



### SUBMERSIBLE PUMP ELEGANT

**Code** CM1300.01.00

#### Technical Specifications

Voltage : 12 Volt DC  
 Maximum current : 2.2 A  
 Capacity : 10 liters/dk  
 Pressure Altitude : 5.5 m (maks.)  
 Pressure : 0.55 bar  
 Consumption : 15 - 24W  
 Height : 104mm



### SUBMERSIBLE PUMP ECO-PLUS

**Code** CM1380.79.00

#### Technical Specifications

Voltage : 12 V  
 Maximum current : 3.5 A  
 Capacity : 10 liters/dk  
 Pressure Altitude : 8 m (maks.)  
 Pressure : 0.8 bar  
 Consumption : 30 - 45W  
 Height : 165mm



### SUBMERSIBLE PUMP VIP-PLUS

**Code** CM1430.12.00

#### Technical Specifications

Voltage : 12 V  
 Maximum current : 3.8 A  
 Capacity : 20 liters/dk  
 Pressure Altitude : 11 m (maks.)  
 Pressure : 1.1 bar  
 Consumption : 35 - 45W  
 Height : 123mm



### SUBMERSIBLE PUMP OCEAN

**Code** CM1104.92.00

#### Technical Specifications

Voltage : 12 V  
 Maximum current : 5 A  
 Capacity : 21 liters/dk  
 Pressure Altitude : 15 m (maks.)  
 Pressure : 1.5 bar  
 Consumption : 45 - 60W  
 Height : 124 mm



# WATER SYSTEMS



## Innovations

4-chamber self-priming diaphragm pump for potable water designed for constant and high flow. Innovative inner membrane made of one piece to ensure anti-vibration sealing, anti-vibration base, brass pressure switch with constant calibration and external filter for easy maintenance (optional for 10l version). Improved motor with high efficiency to provide high capacity with low power consumption.

## Installation

It can be installed anywhere and dry without damage. with  $\varnothing$  13 mm pipes (delivered as standard for the 13l version, optionally delivered for the 10l version) or snap fittings with 1/2" female thread and  $\varnothing$  13mm hose joint (standard

## Versions

Two versions available, 13 and 10l flow rate. The 10l model is indicated for standard circuits that do not require high flow rate, it is a low power consumption and more economical version, filter and



## Aqua 8, more liters per minute, less noise and excellent performance

The Aqua 8 is the classic Fiamma pump for several generations. From this solid foundation, we developed Aqua F, which, thanks to its innovative features, is the ideal choice for drinking water needs.

## AQUA F (13 Liters)



**Code** FIAM07073-01-

### Technical Specifications

Weight : 2,2 kg  
 Power supply : 12 V  
 Consumption (12 V) : 2,5 A  
 Max flow l/min At 0 bar : 13 l/min  
 Noise level : 50 dB  
 Pressure switch : 1,5 Bar / 21,7 Psi  
 Pressure Altitude : 5 m

## AQUA 8



## AQUA F (10 Liters)



**Code** FIAM07073A01-

### Technical Specifications

Weight : 1,4 kg  
 Power supply : 12 V  
 Consumption (12 V) : 1,7 A  
 Max flow l/min At 0 bar : 10  
 Noise level : 52 dB  
 Pressure switch : 1,5 Bar / 21,7 Psi  
 Pressure Altitude : 5 m

## AQUA 8 (10 Liters)



**Code** FIAM01216B01-

### Technical Specifications

Weight : 1.5 kg  
 Power supply : 12 V  
 Consumption (12 V) : 3.4 A  
 Max flow l/min At 0 bar : 10  
 Noise level : 65/70 dB  
 Pressure switch : 1.5 Bar / 21.7 Psi

### Advantages and features

- **Increased flow:** Thanks to the 3rd and 4th piston feature, the Aqua F product provides a water flow rate of 10 L and 13 L per minute
- **Constant water flow:** the largest number of pistons, each supported by an inlet valve (exterior pictured) and an outlet valve (four internal), exerts a constant thrust; This translates into a continuous flow of water. To achieve the best performance, we recommend using the A20 expansion tank.
- **Noise:** Several factors contribute to reducing vibration, making this pump even quieter:
  - More balanced pressure
  - Rubber membrane in one piece
  - Compact mechanical transmission
  - Anti-vibration base

### A safe and reliable pump with many certifications:

- ECE ONU R10
- RCM N136
- DM 174/2004
- AB 10/2011

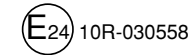

Description	Product Code	Weight
Kit filter Aqua F	98657-014	0,6 kg
Kit connection Aqua F	98657-013	0,3 kg

## AQUA 8 (7 Liters)



**Code** FIAM01216C01-

### Technical Specifications

Weight : 1.5 kg  
 Power supply : 12 V  
 Consumption (12 V) : 1.4 A  
 Max flow l/min At 0 bar : 7  
 Noise level : 55/60 dB  
 Pressure switch : 1.5 Bar / 21.7 Psi

## A20 BALANCER



**Code** FIAM02478-01-

### Technical Specifications

Weight : 0.3 kg  
 Dimensions (WxHxD) : 154x98x234 mm

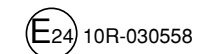

# WATER TANKS

---

CLEAN WATER TANKS

WASTE WATER TANKS

ACCESSORIES



# CLEAN WATER TANKS

## ROLL-TANK 40 LITERS



40 liter fresh water tank with easy grip handle and two large wheels making it easy to transport even on gravel. Made from non-toxic material. It is easily cleaned thanks to its wide cover.

## ROLL-TANK 23 LITERS



Convenient and portable 23 liter clean water tank with easy access discharge cover. Compact size (fits on regular vehicle doors). Supplied with extra cover for immersion pump (not included).

## TANK 70 LITERS



70 liter clean water tank. It can be mounted vertically or horizontally. Comes with all necessary fittings for installation.

Water inlet pipe : Ø 38 mm  
Water air outlet : Ø 13 mm

Description	Product code	Weight
Roll-Tank 23 F	FIAM02428A01A	2,4 kg
Roll-Tank 40 F	FIAM02428-01A	3,8 kg
Tank 70	FIAM01537-01-	4,4 kg
Water inlet cover white	FIAM94715-010	0,2 kg
Water inlet cover black	FIAM94715-005	0,2 kg







# WASTE WATER TANKS

## ROLL-TANK 23 LITERS



Practical and portable 23 liter waste water tank with total discharge head. Compact size (fits on regular vehicle doors).



## ROLL-TANK 40 LITERS



40 liter waste water tank with level indicator and air release valve. Filling and draining is accomplished via a Sanitary-Flex drain pipe (not included). 45° angle adapter for discharge is included.

## QUICK CONNECT W



Adapter to convert threaded connection to bayonet connection allows easy connection of Sanitary Flex to Tank 23 W

## KIT SANITARY FLEX



The flexible hose can be extended to 300cm. It is delivered as standard with 2 connectors that can be connected to 40W, Tank 21W and Quick Connect W.

Description	Product code	Weight
Roll-Tank 23 W	FIAM02428A01-	2,4 kg
Roll-Tank 40 W	FIAM02428-01-	3,9 kg
Kit Sanitary Flex 300	FIAM02438A01-	0,8 kg
Hızlı Bağlantı W	FIAM06497-01-	0,2 kg

## WASTE WATER TANK



Ideal for camping, caravan and entertainment. Can be carried in any storage space.

- Easy to manipulate thanks to retractable carrying handle (up to 810 mm in length)
- Easy to fill, empty and close

Capacity : 25 litre  
 DIN : DIN 96  
 Dimensions (WxHxD) : 335x500x240 mm  
 Weight : 3,1 kg

**Code** CM8690.57.12\_25

## COOLING SYSTEMS

ROOF-MOUNTED AIR CONDITIONER  
FLOOR TYPE AIR CONDITIONER  
ACCESSORIES







Code TU36413-01

**Truma iNet X Panel**

The new Truma iNet X Panel enables the connection and control of Truma products and other devices. Additional additions and updates are possible as part of the Truma iNet X system, so your vehicle will get smarter and smarter.

**Technical Specifications**

Touch screen	TFT-LCD 4,3" (resistant)
Power source	12 V (8 V - 16 V )
Interfaces	TIN-Bus, CI-Bus, CAN-Bus, Bluetooth
Power consumption	1,5 W ( 0.13 mAh )
Battery	Lithium 3V CR 2032
Dimensions	120,1x96,7x31 mm
Weight	Approximately 150g

**Highlighted technical features**

- 4.3" Color screen
- Touch screen operation
- Backup battery - settings are retained even in the event of a power outage
- Control via smartphone possible (via Bluetooth)
- Updatable
- Intuitive and multilingual menu navigation
- External and internal temperature sensors
- Can be expanded to include elements of the Truma iNet X system, such as a remote control
- Smart fan control
- Smart heating and hot water supplement



**Truma iNet X App**

It is also possible to control it via your own smartphone with the free app - the menu navigation is analogue to the operating system.



For more information on the range of functions available and further technical details you can visit our website

<https://www.truma.com/inet-x-panel>

# Smart Device Control Maximum Comfort and Security

## Truma iNet X System: Heater control with the Truma iNet X application on your smart devices!

With Truma's iNet X system, it is now very easy to control the heaters and ventilation systems in your vehicles anywhere and anytime. With the iNet X App, you can easily control all the central features of your caravan via Bluetooth.

### What do our customers need to install the Truma iNet X System?

- Truma iNet X Panel is the main part of the system.
- Truma devices that can be operated with iNet X (Truma combi boiler systems, Aventa air conditioning systems, Saphir floor type air conditioning systems) are suitable for iNet X use.
- You can download and install the Truma application on your smartphone or tablet for free.

### How does the Truma iNet X System work?

Truma iNet X Panel has a central control unit for many Truma devices. You can establish a network between your smartphone and your heating and ventilation devices and send commands / receive reports to these devices over the internet wherever you are and give the command you want to your device. Operation with iNet The free Truma application is used for our heating and ventilation systems that can work with iNet X. Enjoy the comfort that comes with integrating a combi heater and a Truma ventilation system into the automatic climate control system. (iNet installation is ready with the Truma CP plus control panel). Regardless of how hot or cold the weather outside is, the interior of the vehicle is always ready at a coolness or temperature that will make the customer feel good, depending on their preference!

### Vehicle Status at Your Fingertips

Whether you want to check the levels of your water tank and battery, see the status of your Truma DuoControl or turn your water pump, 12-volt main switch on and off with the iNet X App, you will always have the current status of your Vehicle at your fingertips. If the set temperature or onboard voltage drops, a warning appears on the main screen.

### Truma Application

In addition, the application inside this product includes a navigation function for vehicle leveling and turning the vehicle towards the sun, and instructions for use for all Truma devices. (For example: You can access helpful explainer videos and all videos ever made). Your customers can download the Truma application to their smartphones or tablets free of charge from the **App Store** or **Google Play**.

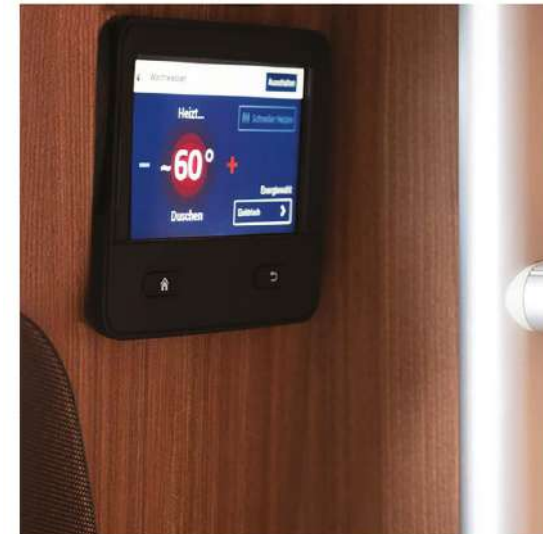

### Installation Overview

You can see an example of how Truma air conditioning systems are installed and recommended accessories. You can see technical details, part numbers as well as our range of necessary accessories on the following pages.

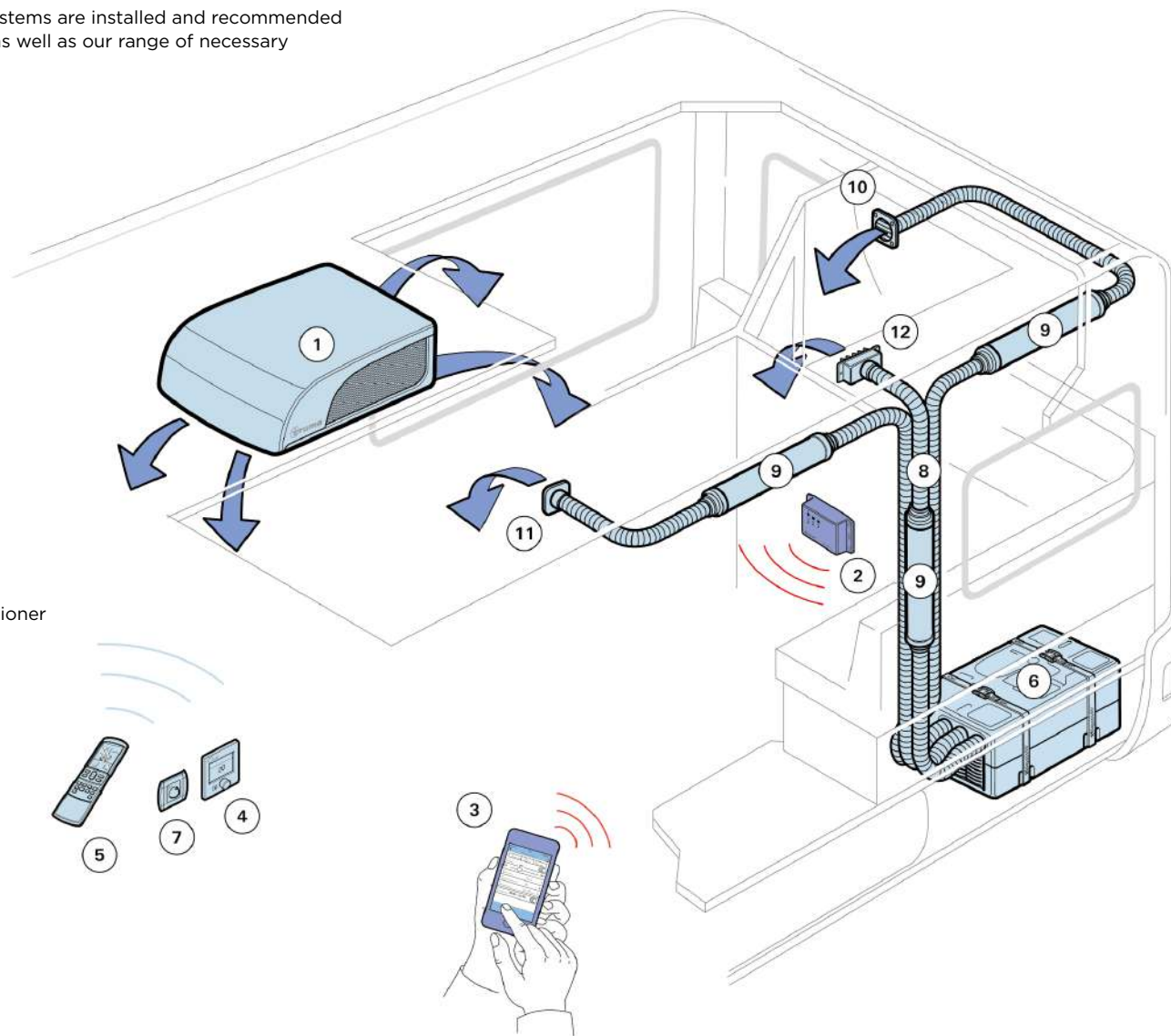

1. Aventa compact/compact plus air conditioner
2. Truma iNet Box remote control system
3. Truma app on smartphone
4. Truma digital control panel
5. Remote control
6. Saphir comfort air conditioner
7. Saphir floor type air conditioner remote control receiver
8. Air suction duct with flexible hose
9. Sound silencer
10. Square air outlet vent
11. 65mm air pipe
12. Blowing center (rectangular)

**AVENTA COMFORT ROOF-MOUNTED AIR CONDITIONER**



**Code** TU44091-51

**Code** TU44091-55



- **Heating and cooling feature combined**
- Ability to work while the vehicle is moving
- High vibration resistant
- Resistant to extreme dust and outdoor particles
- Resistant to severe outdoor conditions
- High performance with low energy
- Illuminated air distribution channel
- Control via remote control
- Fuel savings with engine-independent installation
- Practical timing function
- Strong circulation
- The thinnest air distribution channel in the world
- 8-Way air distribution channel
- Ability to work independently of the engine for 3-5 hours

**Technical Specifications**

Temperature range	: +4°C ile +40°C
Cooling (BTU)	: 8200 BTU
Cooling power	: 2400W
Heating (BTU)	: 5800 BTU
Heating power	: 1700W
Power supply	: 220V (12/24V optional inverter)
Starting Current	: 28 A
Power Consumption	: 220V/4,2 A 12-24V/65A
Thermostat	: Yes
Weight	: 33 kg

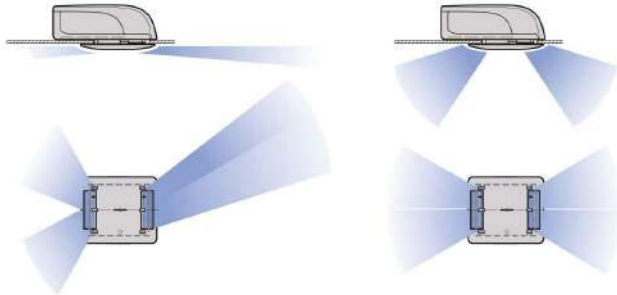

**Note:** Roof cutout 380x350mm or 400x400mm  
Included for roof thicknesses of 25-50 mm (roof thickness adapter up to 110 mm).

- Air distributor lower unit part for Aventa Eco and Aventa Comfort air conditioners.
- It has the thinnest air distribution channel in the world, blowing air in eight different directions
- It is offered to users with two different color options.
- It will increase your comfort with its LED illuminated design.



## **AVENTA COMPACT**

The Aventa Compact offers a range of benefits beneath its compact housing. It is light, quiet and powerful. This is thanks to the use of advanced materials and the constant development of previous Truma roof-mounted air conditioners. Our development engineers were able to reduce the compressor noise to a minimum, for example. This makes the Aventa Compact the quietest roof-mounted air conditioner on the market. Weight is saved by using expanded polypropylene for the housing. This means the Aventa Compact is also the lightest air conditioner in its class.

Its space-saving design makes the Aventa Compact particularly well suited for vans. It can also fit on the roof alongside solar panels, satellite dishes or a roof box. But the roof-mounted air conditioner is perfect for caravans, motor homes and liners too.

The Air distributor small is designed to perfectly fit the Aventa Compact. Like most Truma products, it offers a variety of individual adjustment options. You can adjust the openings to direct the cool air where you need it. Thanks to the Compact and flat design of the air distributor, free movement in the vehicle is hardly affected at all. The roof-mounted air conditioner dries the circulated air while it is running. This helps create a pleasant interior climate, even with minor differences between inside and outside temperature.

The roof-mounted camping air conditioner can also be controlled with the digital Truma CP plus control panel. It is easy to integrate into the iNet System and can be controlled via an app.

- Cools faster than any other roof-mounted air conditioner
- Convenient adjustment using remote control
- Control air conditioner and ACC using the app (optional with Truma iNet Box)
- In connection with the manufacturer's warranty of two years, the
- Fits on even small vehicle roofs
- Extremely quiet running
- Lightest roof-mounted air conditioner on the market
- 5-year guarantee when retrofitted by an authorized Truma dealer



**AVENTA COMPACT ROOF-MOUNTED AIR CONDITIONER**



**NEW**

**Code** TU44200-01

**Code** TU44200-02



**Technical Specifications**

- Power supply : 220V
- Current consumption : 2.8 A
- Starting current : 20 A (150 ms)
- Cooling power : 1700W
- Cooling (BTU) : 5800 BTU
- Air flow max. : 370 m<sup>3</sup> / s
- Application range : +16°C to +40°C
- Maximum slope during operation : % 8
- Weight (without mounting material) approx. : 27.5 kg
- External dimensions (WxHxD) : 560x265x785 mm
- Dimensions (WxHxD) : 496x46x556 mm (air distributor small)
- Dimensions of roof cutting : 350x380 mm / 400x400 mm

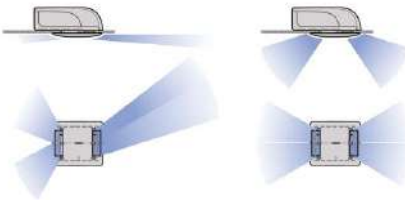

**AVENTA COMPACT PLUS ROOF-MOUNTED AIR CONDITIONER**



**NEW**

**Code** TU44300-01

**Code** TU44300-03



**Code** TU44300-01

**Technical Specifications**

- Power supply : 220V
- Current consumption : 4.3 A
- Starting current : 28 A (150 ms)
- Cooling power : 2200W
- Cooling (BTU) : 7500 BTU
- Air flow max. : 400 m<sup>3</sup> / s
- Application range : +16°C to + 40°C
- Maximum slope during operation : % 8
- Weight (without mounting material) approx. : 29.5 kg
- External dimensions (WxHxD) : 560x265x785 mm
- Alt Ünite Boyut (GxYxD) : 496x46x556 mm (air distributor small)
- Dimensions of roof cutting : 350x380 mm / 400x400 mm

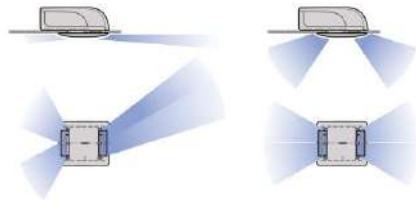

**SAPHIR COMPACT FLOOR TYPE AIR CONDITIONER**



**Code** TU44081-02

- Fuel-free air conditioning system
- It can be used in all cabins you can think of.
- Practical timing function
- Control via remote control
- Quick and easy assembly
- Same comfort in every corner of your location with distribution channels
- Low power consumption

**Technical Specifications**

Cooling power : 1800W  
 Cooling (BTU) : 6150 BTU  
 Power source : 220V  
 (12/24V Optional with inverter)  
 Starting current : 15 A  
 Power consumption : 220V/2,8 A  
 12-24V/55A  
 Thermostat : Var  
 Weight : 20 kg

**SAPHIR COMFORT RC FLOOR TYPE AIR CONDITIONER**



**Code** TU44035-01

- **Heating and cooling comfort combined**
- Extremely quiet in sleep mode
- Practical timing function
- Control via remote control
- Quick and easy assembly
- Ideal for those with allergies thanks to its pollen filter
- World's smallest size in its class

**Technical Specifications**

Temperature range : 16C°/31C°  
 Cooling power : 2400W  
 Cooling (BTU) : 8200 BTU  
 Heating power : 1700W  
 Heating (BTU) : 5800 BTU  
 Power supply : 220V  
 Optional : 12/24V (with inverter)  
 Starting current : 20 A  
 Power consumption : 4,2 A  
 Thermostat : Var  
 Weight : 23.5 kg

**iNet BOX**



- iNet central remote control unit. Can be controlled via smartphone / tablet.

**Code** TU36400-01

**Technical Specifications**

Power supply : 12V/24V  
 Power consumption : 40/20 mA (12/24V)  
 Sim card type : Mini-sim  
 Interfaces : TIN bus (2xTIN 1 switchable, 1xTIN 2)  
 GSM, Bluetooth  
 Bluetooth : Class 2  
 Weight : 150 g  
 Operating temp. range : -30° - +60°



**iNet X PANEL**



**Code** TU36413-01

- iNet X central remote control unit. It can be controlled via smart devices.

**Technical Specifications**

Power source : 12V  
 Power consumption : Approx. 0.125 A  
 Screen : 4.5 inches  
 Interfaces : TIN Bus, CI Bus, CAN Bus,  
 bluetooth low energy  
 Bluetooth : Class 2



# HEATING SYSTEMS

---

- COMBI HEATERS
- RV HEATERS
- WATER HEATERS





## Heat Hybrid

**Mountain biking in spring, hiking in late autumn, skiing in winter: camping fans enjoy a holiday at all times of the year. And thanks to Truma heaters, you don't have to give up any of your familiar comfort. So you can feel right at home when you're on holiday – and even better.**



### Truma Combi

Caravan and Water Heater

Combi heaters from Truma combine two functions in one appliance: they heat the vehicle as well as simultaneously heat the water in the integrated stainless steel container. This saves space and weight in your vehicle. The practical part: In summer mode, if the heater is not required, it is possible to heat up the water independently of the heater.

The Combi heaters from Truma are available as gas or diesel variants. The E-variant is equipped with additional integrated electric heating elements ("Heat Hybrid"). Depending on the model, you can operate your Truma Combi heater in gas, diesel or electrical mode, but also use hybrid.

One appliance, two functions! Heat your vehicle as well as simultaneously heat the water in the integrated stainless steel container for a pleasant shower.

Fast heating or constantly control your temperature, the digital Truma CP plus control panel and the Truma iNet X System enable appliances to be easily controlled in your motor home.

### Flexible source of heat

The Heat Hybrid function which is available on our E models, enables the electrical power to be changed or switched on – meaning you can heat your vehicle even faster.

**Very Practical:** Truma iNet X App can be used to switch on the combi heater from a smartphone.

- **Compact:** A lightweight, space-saving heater.
- **Fast:** The water heats up in a short time.
- **Advanced Design:** Provides the most suitable hot air required for the environment.
- Distribution via four air outlets.
- **Integrated:** Freeze control relief valve is included as standard.

### Hybrid heater Combi 6 E

It offers all the advantages of the Combi model and more: You can also switch to electric operation and thus always have maximum flexibility.

- Up to 25% faster interior heating
- More hot water available
- Installation also possible in small vehicles

HEATING SYSTEM

Winter camping, with the cold climate in Northern Europe and evenings during the freezing months, can be tough on both you and your belongings. Truma has been developing products that will help you overcome these difficult climatic conditions for more than 50 years. It produces and constantly improves mobile heating systems so that you can enjoy your camping holiday even in cold weather.



Mornings in bed, afternoons on the beach or evenings in a restaurant: Thanks to the Truma iNet System, you can conveniently control your Truma devices with the app at any time, wherever you are.



**INSTALLATION OVERVIEW**

Below you can see an example of how Truma heating systems are installed and recommended accessories. You can see technical details, part numbers as well as our range of necessary accessories on the following pages.

- 1. Combi (E) / Combi D (E)
- 2. Truma iNet
- 3. Truma iNet X App
- 4. Room temperature sensor
- 5. Frost Control (FrostControl)
- 6. FrostControl heating element
- 7. Combi (E) / Combi D (E) Wall outlet
- 8. Channel Ø 65 mm
- 9. T-pipe LT/end outlet
- 10. Elbow BG
- 11. End outlet nut EM / end outlet EN
- 12. Wall outlet ventilation WL
- 13. Water hose suitable for drinking water
- 14. Isotherm channel IR, Ø 35 mm
- 15. Lever AB35
- 16. Corner air outlet

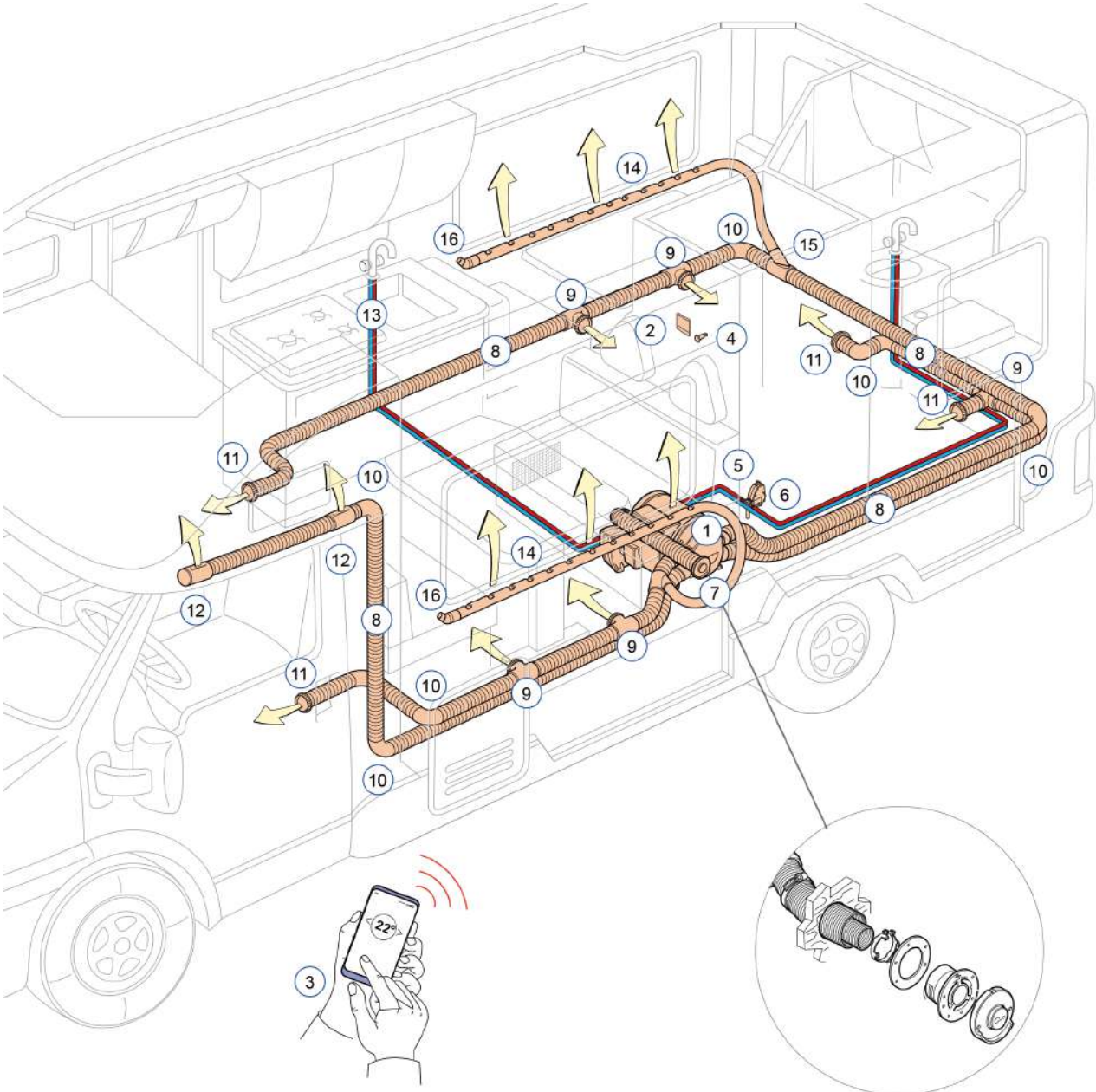

**TRUMA COMBI D4 (DIESEL)**



**Code** TU33406-78

**Technical Specifications**

Heat Output	: 2000 / 4000W
Ignition	: 12 V
Fuel type	: Diesel
Fuel consumption	: 100 ml - 400 ml/h
Water working pressure	: Max 2.8 bar
System pressure	: Max 4,5 bar
Internal Volume	: 10 lt water heating compartment
Water Heating	: Approximately 23 min. (15°C - 60°C)
Valumetric Air Flow	: ax 287 m <sup>3</sup> /hour
Dimensions (WxHxD)	: 510x300x450mm
Thermostat	: Yes
Weight	: Approx. 16 kg

- FrostControl drain valve installed
- Simple control with the digital control panel CP plus (iNet ready) or via iNet X system
- Optimum warm air distribution due to four air outlets
- 10 l stainless steel water tank
- Integrated air pressure sensor automatically regulates the combustion air supply
- Long service life thanks to efficient combustion control
- Economical thanks to low battery power consumption and less diesel consumption through particularly efficient combustion
- Automatic air conditioning possible when using a Truma air conditioning system

**TRUMA COMBI 4 (GAS)**



**Code** TU33704-20

**Technical Specifications**

Heat Output	: 2000 / 4000W
Ignition	: 12V
Power source	: Propan / Butane
Gas consumption	: 160 / 335 g/hour
Gas working pressure	: 30 mbar
Water working pressure	: Max 2.8 bar
System pressure	: Max. 4.5 bar
Internal Volume	: 10 lt water heating compartment
Water Heating	: Approximately 20 minutes. (15°C - 70°C) - 23 min (15°C - 60°C)
Valumetric Air Flow	: Max 287 m <sup>3</sup> / hour
Dimensions (WxHxD)	: 510x300x450 mm
Thermostat	: Yes
Weight	: Approx. 14.4 kg
ID number	: CE-0085BS0085

- FrostControl, the drain valve that works without electricity, fitted as standard
- Digital control panel CP plus iNet ready
- Automatic climate control in combination with a Truma air conditioner
- Water heats up within a short time
- Optimum warm air distribution via four air outlets
- Extremely light and compact, which allows various installation options
- Low energy consumption
- Durable stainless steel water tank
- The Combi 4 heater also works without a filled water tank

**TRUMA COMBI D4 E (DIESEL AND ELECTRIC)**



**Code** TU33416-78

**Technical Specifications**

Heat output gas	: 2000 / 4000 W
Heat output electricity	: 900W-3.9A / 1800W-7.8A (220V)
Ignition	: 12V
Fuel type	: Diesel / 220V
Fuel consumption	: 100 ml - 400 ml/h
Water working pressure	: Max 2.8 bar
Internal volume	: 10 lt water heating compartment
Water heating	: Approximately 20 minutes. (15°C - 60°C)
Valumetric air flow	: Max 287 m <sup>3</sup> /hour
Dimensions (WxHxD)	: 525x300x450 mm
Thermostat	: Var
Weight	: Approx. 16.8 kg

- Can also be operated with an empty water tank
- FrostControl drain valve is installed
- Simple operation with the digital Truma CP plus (iNet ready) control panel or via iNet X System
- Optimum warm air distribution via four air outlets
- 10-litre stainless steel water tank
- Compact and space-saving, various installation options
- Heats the vehicle and water very quickly
- Uses little energy
- Integrated pressure sensor automatically controls the combustion air infeed
- Long service life thanks to efficient combustion control
- Automatic climate control possible in combination with a Truma air conditioner





### TRUMA COMBI 4E (GAS AND ELECTRIC)



**Code** TU33714-20

#### Technical Specifications

Heat output gas	: 2000 / 4000W
Heat output electricity	: 900W-3.9A / 1800W-7.8A (220V)
Ignition	: 12V
Power supply	: Propane / Butane / 220V
Fuel consumption	: 160 / 335 g/hour
Gas working pressure	: 30mbar
Water working pressure	: Max 2.8 bar
System pressure	: Max. 4.5 bars
Internal volume	: 10 lt water heating compartment
Water heating	: Approximately 20 minutes. (15°C - 70°C) 23 min (15°C - 60°C)
Valumetric air flow	: Max 287 m <sup>3</sup> / hour
Dimensions (WxHxD)	: 510x300x450 mm
Thermostat	: Yes
Weight	: Approx. 15.5 kg
ID number	: CE-0085BS0085

- Digital CP plus iNet ready control panel: automatic climate control in combination with a Truma air conditioner
- FrostControl automatically empties the water tank in cold weather

#### Further Highlights:

- With integrated heating elements for additional electrical mode
- Heats the vehicle and water very quickly
- Uses little energy
- Many installation options as it is extremely lightweight and compact
- The warm air from Combi 4 E is distributed optimally via four air outlets
- Gas, electrical and mixed modes are possible

### TRUMA COMBI 6 (GAS)



**Code** TU33804-20

#### Technical Specifications

Heat output	: 2000 / 4000 / 6000W
Ignition	: 12V
Power source	: Propane / Butane
Fuel consumption	: 160 / 460 g/hour
Gas working pressure	: 30 mbar
Water working pressure	: Max 2.8 bar
System pressure	: Max. 4.5 bars
Internal volume	: 10 lt water heating compartment
Water heating	: Approximately 20 minutes. (15°C - 70°C) 23 min (15°C - 60°C)
Valumetric air flow	: Max. 278 m <sup>3</sup> /h
Dimensions (WxHxD)	: 510x300x450 mm
Thermostat	: Yes
Weight	: Approx. 14.4 kg
ID number	: CE-0085BS0085

Combi 6 combines two functions in one appliance: space and water heating. The especially lightweight, compact heater ensures pleasant temperatures in larger caravans and motor homes. The heater contains a 10-litre stainless steel water tank which is also heated in winter. In summer, you can heat just the water without using the space heater. The water reaches a temperature of 60 degrees in about 20 minutes - perfect for a shower after an arduous mountain bike tour.

### TRUMA COMBI 6E (GAS AND ELECTRIC)



**Code** TU33814-20

#### Technical Specifications

Heat output	: 2000 / 4000 / 6000W
Heat output electricity	: 900W-3.9A / 1800W-7.8A (220V)
Ignition	: 12V
Power supply	: Propane / Butane / 220V
Fuel consumption	: 160 / 460 g/hour
Gas working pressure	: 30 mbar
Water working pressure	: Max 2.8 bar
System pressure	: Max. 4.5 bars
Internal volume	: 10 lt water heating compartment
Water heating	: Approximately 20 minutes. (15°C - 70°C) 23 min (15°C - 60°C)
Valumetric air flow	: Max 278 m <sup>3</sup> /hour
Dimensions (WxHxD)	: 510x300x450 mm
Thermostat	: Yes
Weight	: Approx. 15.5 kg
ID number	: CE-0085BS0085

The Combi 6 E is an air heater with integrated water heater. It differs from the Combi 6 by the integrated electric heating elements. For example, you can operate the heating on gas, on electricity or on both at the same time. For stationary use at the campsite, you can operate the Combi heater with the 12V power supply without using the batteries at all.

- Intuitive operation of the Combi 6 E via the digital control panel CP plus iNet ready
- Automatic climate control possible in combination with Truma air conditioning
- Currentless drain valve FrostControl integrated

### TRUMA COMBI D6 (DIESEL)



**Code** TU33505-20

#### Technical Specifications

Heat Output	: 2000 / 4000 / 6000W
Ignition	: 12V
Fuel type	: Diesel
Fuel consumption	: Normal operation with average heat output 220-630ml/h during (1000W): 110ml/h
Water working pressure	: Max 2.8 bar
System pressure	: Max. 4.5 bar
Internal volume	: 10 lt water heating compartment
Water heating	: Approximately 20 minutes. (15°C - 70°C) 3 min (15°C - 60°C)
Valumetric air flow	: Max 287 m <sup>3</sup> /hour
Dimensions (WxHxD)	: 525x300x450 mm
Thermostat	: Yes
Weight	: Approx. 15.8 kg

- FrostControl drain valve is installed
- Simple operation with the digital Truma CP plus (iNet ready) control panel or via iNet X System
- Optimum warm air distribution via four air outlets
- 10-litre stainless steel water tank
- Integrated pressure sensor automatically controls the combustion air infeed
- Long service life thanks to efficient combustion control
- Economical due to very low battery power consumption and lower diesel consumption thanks to particularly efficient combustion
- Automatic climate control possible in combination with a Truma air conditioner
- 2 in 1: heats your vehicle and heats water at the same time
- Also works with an empty water tank
- Compact and space-saving, various installation options

### TRUMA COMBI D6 E (DIESEL AND ELECTRIC)



#### Heat Hybrid

**Code** TU33515-20

#### Technical Specifications

Heat output gas	: 2000 / 4000 / 6000W
Heat output electricity	: 900W-3.9A / 1800W-7.8A (220V)
Ignition	: 12V
Fuel type	: Diesel / 220V
Fuel consumption	: Normal operation with average heat output 220-630ml/h during (1000W): 110ml/h
Water working pressure	: Max 2.8 bar
Internal volume	: 10 lt water heating compartment
Water heating	: Approximately 20 minutes. (15°C - 70°C)
Valumetric air flow	: Max 287 m <sup>3</sup> /hour
Dimensions (WxHxD)	: 525x300x450 mm
Thermostat	: Yes
Weight	: Approx. 16.9 kg

- FrostControl drain valve is installed as standard
- Simple operation with the digital CP plus iNet ready control panel
- Automatic climate control possible in combination with a Truma air conditioner
- With integrated heating elements for additional electrical mode
- Powerful fan and even distribution of warm air
- Uses little energy
- Especially lightweight and compact; can be installed in various positions to save space



## COMBI ACCESSORIES

### iNET X PANEL



**Code** TU36413-01

• iNet X central remote control unit. It can be controlled via smart devices.

#### Technical Specifications

Power supply : 12 V  
 Power consumption : Approx. 0.125 A  
 Screen : 4.5 inches  
 Interfaces : TIN Bus, CI Bus, CAN Bus,  
 bluetooth  
 Bluetooth : Class 2

### COMBI DIESEL EXHAUST

**Code** TU34400-02  
BIANCO

**Code** TU34400-03  
BLACK

**Code** TU34400-04  
ANTHRACITE



**Note:** Complete with extractor fan and connector cable (without sound muffler and exhaust hoses)

### COMBI DIESEL FUEL HOSE

**Code** TU34020-69800



### COMBI DIESEL CELLULAR RUBBER HOSE

**Code** TU34020-70000



**Note:** For acoustic separation of the fuel line.

### COMBI HOSE HOLDER

**Code** TU34020-76000



Individual parts for routing the fuel line: The combi heater you will receive includes a standard 8m fuel hose, 6m cellular rubber hose, 10 hose holders and 1 spare lock washer. The above products are spare parts.

### COMBI DIESEL EXHAUST SILENCER

**Code** TU34501-01  
60 cm

**Code** TU34501-02  
70 cm

**Code** TU34501-03  
100 cm

**Code** TU34501-04  
150 cm



### WATER CONNECTION KIT



**Code** TU36100-01  
water connection kit FC TB



**Code** TU36100-02  
water connection kit FC JG

## COMBI HEATERS | Truma

### FROST CONTROL HEATING ELEMENT

**Code** TU70070-01



Switch for faster filling of the water container according to room temperature

### COMBI DIESEL EXHAUST SILENCER CONTROL PANEL CABLE

**Code** TU36110-01  
3 m control panel cable

**Code** TU36110-02  
6 m control panel cable

**Code** TU36110-03  
9 m control panel cable



### WINDOW SENSOR

**Code** TU34030-34700



Window sensor for connection of combi (E) heaters to the automatic shut-off device

**Note:** The window sensor is also required to automatically switch off the device. The sensor is placed under a window opening 30 cm away. (Complies with EN 1949). Suitable for windows of all caravans.

### HIGH ALTITUDE KIT

**Code** TU34610-01



Truma high altitude kit is a kit that allows you to operate your heater for longer periods at altitudes between 1500 and 2750 meters.

## ENJOY THE LUXURY!

### Discover unlimited hot water feature with Alde Flow!

The Alde central heating system is a hydronic system, with the same heating principle as in most of our homes. The heat source comprises a LPG boiler with an immersion heater, which heats a liquid mixture consisting of water and glycol. Hot glycol water circulates around the system through radiators and pipes by means of a pump. The convectors that are placed along the outer walls heat the air. This then rises and heats the walls and furniture. Since hot air rises, an air barrier is formed in front of the windows, which keeps the chill off. When the warm air reaches the ceiling, it circulates down towards the floor and is reheated by the convectors. Each vehicle must have ventilation, i.e. fresh air needs to be supplied and used air expelled. The supplied fresh air in the vehicle should be directed in through an insulated air intake and on up through a convector with closely spaced slats. In this way the incoming fresh air is heated when the heating system is operational. The used air is ventilated out through the roof panel and ventilators.

The installation is important to produce the best heat distribution and pleasant heating.

- As many and as long convectors as possible.
- Convectors must be placed under each window.
- The convectors are installed along and up against the outer walls.
- Air must be able to pass under beds and behind backrests.
- Ventilation in the cabinet so that air can circulate.

If the installation is correct, the natural flow of heat from the Alde central heating system means that the entire living space is wrapped in a comfortable environment, which shuts out draughts, eliminates cold spots and also heats both beds and cabinets. The installation of underfloor heating is also recommended to give a very complete heating system with maximum comfort. The heating pipes in the floor are connected to the ordinary pipe system.

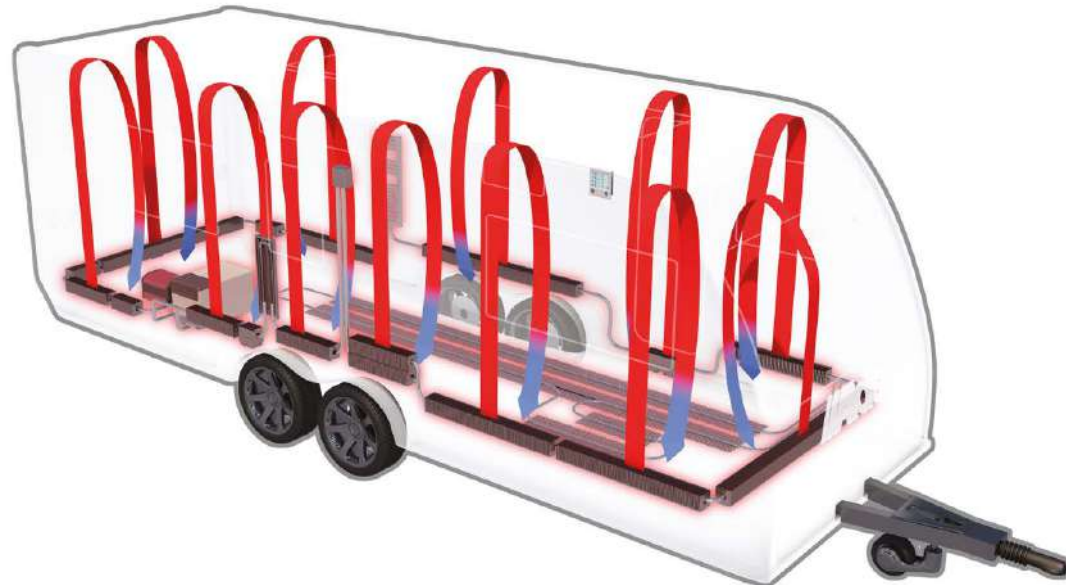
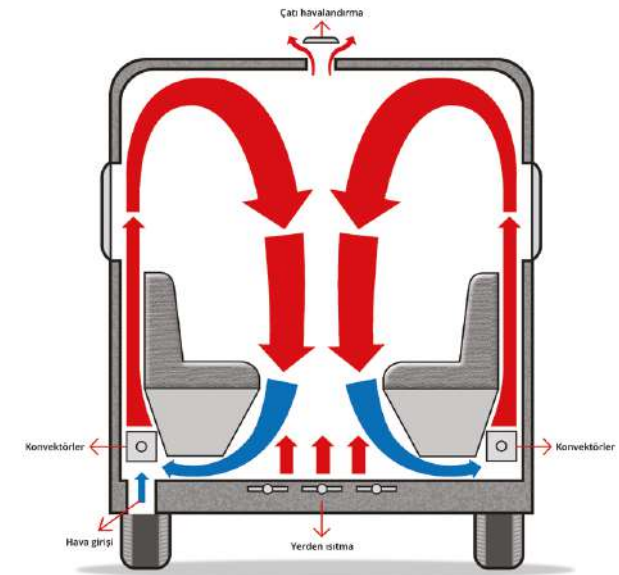

## ALDE COMPACT 3020 HE



**Code** AL30209090

### Boiler for mobile leisure vehicles

All connections – fluids, gas and electricity – are located on the long side. This makes it easy to install and service the Compact 3020 HE. The installation dimensions will also be minimal as there are three sides which are completely free.

Inside the metal surround of the Compact 3020 HE is the LPG powered burner which works with two output steps depending on the output needed.

All of the Compact 3020 HE models are equipped with two 230 V electric elements with a maximum output of 3150 W. The hot water heater in the boiler is of storage type and can hold more than 8 litres of fresh water. Control of the boiler is via a processor on the boiler's circuit board. Alde Compact 3020 HE can be connected to most models\* of Truma AC and therefore give full climate control.

The Compact 3020 HE can generally be installed wherever you want. Either inside the living space, such as e.g. in a wardrobe or stowage space, or installed outside in any storage area or in a space between floors. Release of exhaust gas and intake of air can either be via a sidemounted flue or one fitted on the roof.

### Technical Specifications

Boiler height	: 310 mm
Boiler depth	: 340 mm
Boiler width	: 510 mm
Weight	: 14 kg (without fluid)
Gas	: Propane                      Butane
	Output 1 : 3,3 kW      3,8 kW
Consumption	: 245 g/h                      275 g/h
	Output 2 : 5,5 kW      6,4 kW
Consumption	: 405 g/h                      460 g/h
Pressure	: 13+ 28-30/37 mbar.      13B/P 30 mbar
Volume of liquid, radiator water	: 3,5 Liter
Max pressure radiator water	: 0,05 MPa (0,5 bar)
Volume of liquid, domestic hot water	: 8,4 liter
Max pressure domestic hot water	: 0,3 MPa (3,0 bar)
System temperature (max.)	: 80 °C.
Output element (2 or 3 kW)	: 230-240 V~: 1 × 1050 W + 1 × 2100 W.
Current consumption 12 V DC	: 1,9 A (max)

\* Truma Aventa (comfort, eco, compact, compact plus).

Truma Saphir comfort RC, Truma Saphir compact (from serial no. 23091001)

## ALDE FLOW



**Code** AL3020161

Shower as long as you want with the Alde Flow! Allowing continuous hot water, the Alde Flow is a supplemental heat exchanger connected to the 3020 Compact HE system. By increasing the surface area between the central heating and hot water, the water can be heated as it flows through the system without needing a large storage tank.

Alde Flow, in combination with Alde Compact 3020 HE\* in boost mode and with a flow of 3.5 litres per minute (equal to a standard caravan/motorhome shower) gives you continuous 40 °C shower water as long as you have a fresh water supply. For pre-2016 Alde Compact models, Alde Flow functions as auxiliary 6 litre hot water storage.

### • Unlimited hot water!

### Technical data

Breadth	: 225 mm.
Height	: 180 mm.
Depth	: 320 mm, without pump.
Weight	: 2,3 kg.

### Discover unlimited hot water feature with Alde Flow!

## ALDE COMPACT 3030 PLUS



New Alde Compact 3030 Plus, with even more heating and hot water comfort

- Prepared for 2-zone system.
- 20% larger water heater. Now 10 litres.
- Continuous hot water via a built-in heat exchanger.
- Simpler, more modern user interface in the control panel.
- Upgraded Alde Intelligent Climate Technology (ICT).

### Boiler construction

Alde Compact 3030 Plus internal heat exchanger consists of three concentric cylinders; the combustion chamber, the central heating cylinder and the hot water cylinder. The combustion chamber is made from aluminium, and is divided into two halves by a baffle plate, with the burner head located in the top half, and the flue gases venting through the bottom half. The combustion assembly is fixed to the end of the internal heat exchanger. It consists of the burner, combustion fan, gas valve, air intake and exhaust ducts, and gas line. Two electric heating elements are sealed inside the central heating cylinder, one for 1 kW, one for 2 kW. The room thermostat is integrated into the touchscreen control panel and connected to the boiler by a Registered Jack (RJ) cable.

### The advantages of a 2-zone system

With a 2-zone system, the bedroom section can be set to a lower temperature, while e.g. the kitchen / seating area can have a higher temperature. This is perfect in many of today's campers and RVs, where the bedroom section is properly separated from the kitchen / seating area.

This not only increases overall comfort, it also saves fuel (LPG or electricity). The system is installed with separate convector circuits for each zone, where the temperature can be set individually.

### New control panel User Interface

Alde heating system is controlled via the classic touch control panel. Coinciding with the launch of the Compact 3030, we are upgrading the control panel with a new, more intuitive user interface. In addition to controlling two optional heating zones, a label-driven interface was designed to make functions more descriptive.



### Alde's Intelligent Climate Technology (ICT)

Alde's Intelligent Climate Technology automatically provides smooth, effective temperature transitions; the boiler calculates whether it needs to raise output or not to achieve the selected temperature. This is to avoid unnecessary energy being consumed and to ensure that the prioritised energy source is always used in first instance, unless there is an actual need to activate both electricity and gas. The boiler never uses more power than necessary.

In addition to the usual temperature setting, Alde's smart system includes Night Mode and Day Mode functions, which provide the ability to increase comfort by automating temperature changes and switching selected functions on or off during the day or night.

When a Truma AC\* is connected to the Alde system and an Alde outside temperature sensor, you enjoy the additional functionality of Alde's intelligent climate technology. The AC is controlled from the same sensor as your Alde Heating System and can be controlled by the same smart Alde technology. If the Truma also has a heating function, it assists with the rapid heating of a cold vehicle.

\* Truma Aventa (comfort, compact, compact plus). Truma Saphir comfort RC, Truma Saphir compact (from serial no. 23091001).

**Code** AL30309191

**ALDE AQUACLEAR UNIVERSAL**



**Code** AL3030034

**Help yourself to clean water**

Alde AquaClear is a robust, efficient 12 V water disinfection product for greater water quality security in low pressure systems where the water is filled externally and stored in a tank, with a consequent higher risk of microbiological growth.

This model can be retrofitted to all Alde boilers (we recommend 3030033 for Alde Compact 3030/3030 Plus). Also suitable for other water systems where a 12 V fresh water pump is installed.

Disinfection is based on UV-C light through the latest UV-C LED technology and the Alde Water Carbon Filter. The product neutralizes around 99% of the micro-organisms during water flow (up to 4 litres per minute).

Alde AquaClear is connected to the control panel supplied. When the control panel is lit, the filter is active.

Alde AquaClear has a service life of around 70 cubic metres of water, or approx 300 hours of active operation. (With an approximate usage of 20 minutes per day, product lifetime is around 900 days.)

Because the pressure drop across Alde AquaClear is up to 0.9 bar, we recommend a freshwater pump with a pressure of at least 2 bar.

Contains: Water purification unit, clamps, control panel 3 m cable, adapters for 12 mm hose and charcoal filter.

**Advantages with Alde AquaClear**

- Eliminates contaminants such as legionella and e- coli bacteria via UVC light.
- Treatment free of chemicals and mercury.
- Carbon filters maximize chlorine reduction, bad taste and bad odour.
- Low energy consumption – active only when water pump is active.
- Compact solution and simple installation.

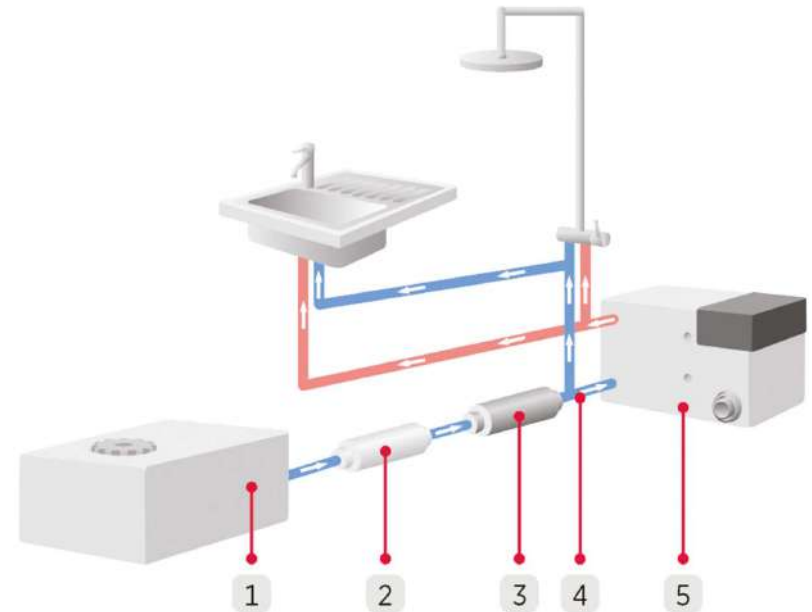

**How it works**

1. Cold water is pumped from the fresh water tank using the fresh water pump.
2. The water is purified in the first stage of the Alde AquaClear UV-C unit.
3. The water is purified in second stage via the Alde Water Carbon filter.
4. Then the water goes on to a T-connection and from there as cold water to the kitchen and shower and to Alde Boiler.
5. Cold water is heated in Alde Boiler and goes from there as hot water to kitchen and shower.

### TOUCH SCREEN CONTROL PANEL



**Code** AL3020101

For users with an older control panel for Alde Compact 3020 HE, they can now update to the latest model, 3020 HE iNet ready.

The Alde Control Panel is based on the latest technology. Its 3.5" TFT touchscreen makes it easy to navigate through the various functions. The screen resolution ensures a clear picture in both daylight and darkness. The control panel also features a user-friendly interface, with self-explanatory menus in colour.

### CIRCULATION PUMP



**Code** AL3010507

Factory-fitted circulation pump 12 V for mounting on the Compact 3030 and Compact 3020 HE.

Five speed with adjustable dial on motor.

Must not be installed on Compact 3030 Plus with a single zone.

Power consumption 12 volts: 0.25 - 1.9 A. Ø 22 mm connection.

### INLINE CIRCULATION PUMP



**Code** AL3020049

Factory-fitted circulation pump for Compact 3030 and Compact 3020 HE.

Five speed with adjustable dial on motor.

Must not be installed on Compact 3030 Plus with a single zone.

Power consumption 12 Volt: 0.25 - 1.6 A. Ø 22 mm connection.

### INLINE CIRCULATION PUMP - REMOTE CONTROLLED



**Code** AL3020031

Circulation pump for mounting on Compact 3030, 3030 Plus and 3020 HE.

Connected to control panel to allow remote control of pump speed by PWM. Five speeds.

Power consumption 12 V: 0.25 - 1.6 A. Ø 22 mm connection.

### ALDE OUTDOOR SENSOR



**Code** AL3010299

Sensor with 2.5 m cable for measuring outdoor temperature. The temperature is indicated on the control panel display. For control panels 3010213 / 413 / 613 and 3020112 For Alde Compact 3020 connect to boiler's PCB.

### PLASTİK BACA KAPAĞI



**Code** AL3010391

Flue caps in different colours for side-fitted flue terminals.

### ALDE COMPACT 3020 WALL FLUE



**Code** AL3010170

Flue for side installation. Delivered with hose clips for exhaust hose and inlet hose. Size of hole Ø 83 mm.



**WALL FLUE CAP**



**Code** AL3010171

Cap in different colors for wall flue.

**ALDE COMPACT 3020 HEAT SENSOR**



**Code** AL3020039

Sensors for thermostat, overheating protection and domestic hot water.

**ROOM THERMOSTAT**



**Code** AL2900560

Room thermostat 12 V for Comfort boilers.

**ALDE HIGH ALTITUDE VALVE**



**Code** AL4115101

The Alde high altitude valve can be engaged manually when you are at altitudes above 1,000 metres. The high-altitude valve reduces the pressure in the burner to adapt it to the lower air pressure.

**ALDE THERMOSTATIC MIXING VALVE 3**



**Code** AL3102006

Thermostatic mixing valve with wall-mounting bracket. For prevention of hot water scalds by mixing hot water with cold before the outlet. Warm water temperature adjustable between 30 to 40 °C. Quick response with emergency cut-off and sediment filters. Highest standard, suitable for nursery and elderly care environments. Integral Ø 12 mm JG Speedfit connections, no adaptors necessary.

**Technical Specifications**

- Breadth : 101 mm.
- Height : 93 mm.
- Depth with bracket : 30 mm.
- Weight : 0,3 kg.
- Maximum working pressure : 5,0 bar.
- Minimum working pressure : 0,2 bar.
- Minimum flow rate 15 mm : 1 l/min.
- Temperature, hot supply : 55 °C - 65 °C (max 85 °C).
- Temperature, cold supply : 5 °C - 25 °C.

**ALDE COMPACT 3020 HE CIRCUIT BOARD**



**Code** AL3020140

Circuit board with ignition transformer.

**CIRCULATION PUMP WITH SCREW PLINTH**



**Code** AL2928433

Circulation pump 12 V for installation in the expansion tank 3000420, 3000495, 2930410 and 2930413. Plug. Power consumption 0.2 A.

**LEAD FOR 12 V INLINE CIRCULATION PUMP**



**Code** AL3010237

Lead to connect boiler and 12 V inline circulation pump. Plugs into both JP12 and JP10 socket on PCB. Length 0.2 m.

**DOMESTIC WATER CONNECTION**



<b>Code</b>	AL3000470 10 mm
<b>Code</b>	AL3000570 12 mm

Angle 90° for cold water.  
Fits all Compact 3000 and 3010 up to series no. 91458.  
Ø 10 mm ve 12 mm

**HEATING MAT FIAT, CITROEN AND PEUGEOT**

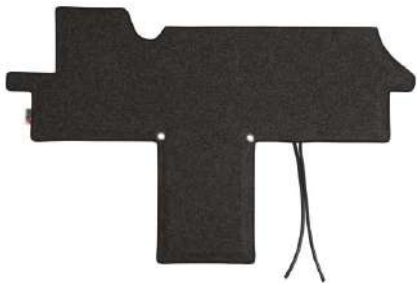

<b>Code</b>	AL1500332
-------------	-----------

Heating mat for the floor of the cab in the camper.  
The heating mat is made of materials from the commercial vehicle industry: heat-resistant PU foam, temperature safe to 90° C and water repellent.

Eyelets for attaching the mat.  
Ø 12 mm hose connections to convector system.

Only available in Left-Hand Drive.

**HEATING MAT MB SPRINTER 2020-**



<b>Code</b>	AL1500333
-------------	-----------

Heating mat for the floor of the cab in the camper.  
The heating mat is made of materials from the commercial vehicle industry: heat-resistant PU foam, temperature safe to 90° C and water repellent.  
Eyelets for attaching the mat.

Ø 12 mm hose connections to convector system.

Only available in Left-Hand Drive.

**CONVECTORS**

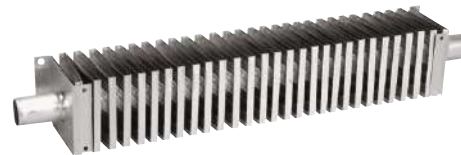

<b>Code</b>	AL1900385 400 mm Length
<b>Code</b>	AL1900384 700 mm Length
<b>Code</b>	AL1900383 1000 mm Length
<b>Code</b>	AL1900382 1300 mm Length
<b>Code</b>	AL1900381 1600 mm Length
<b>Code</b>	AL1900380 1900 mm Length

Convectors in aluminium.

**Technical data**

Height including mounting : 60 mm  
Depth including mounting : 65 mm  
Power : 400 W/m at ΔT= 50 °C.  
Weight : 0.67 kg/mincluding liquid.  
Pipe : Ø 22 mm

**FLOOR HEATING PLATE**



<b>Code</b>	AL1500300 1000x180x0,3 mm
<b>Code</b>	AL1500305 1000x315x0,3 mm

Floor plate of aluminium for Ø 12 mm pipe.

The thin aluminium heating plates, only 0.3 mm, are perforated so that glue can penetrate through resulting in better adhesion to the surface material.

**HEATED TOWEL RAIL - BRAVO**



<b>Code</b>	AL1900618
-------------	-----------

Heated towel rail in chrome-plated steel tubing which is assembled directly into the normal central heating system.  
Bleed screw at the top of the heater.  
661 x 302 mm. Ø (22 mm) connection.

Use holder 1900615 for installation.

## PANEL RADIATOR



Designed panel radiator in aluminium. Suitable for confined spaces such as toilets, wardrobes, in which it is difficult to install an ordinary convector. Includes bleeder screw on top.

For Ø 22 mm heating system.

### Technical Specifications

Power : 110 / 150 W at  $\Delta T = 50\text{ }^{\circ}\text{C}$   
 Height : 500 / 700 mm  
 Breadth : 220 mm  
 Weight : 1.7 / 2.4 kg  
 Connection : Ø 22 mm

Size	Color	Code
500 mm	White (RAL 9016)	<b>AL1900686</b>
500 mm	Silver (RAL 9006)	<b>AL1900687</b>
700 mm	White (RAL 9016)	<b>AL1900680</b>
700 mm	Silver (RAL 9006)	<b>AL1900681</b>

## ALDE VOICE CONTROL



**Code** AL3020190

With Alde Voice Control, you can control your Alde heating system with your voice using a microphone (sold separately). Say a command to set or activate different functions such as temperature, hot water and air conditioning. Available in 4 languages: English, German, French and Swedish.

**Contents:** Connection cable for gateway, control panel, antenna and manual.

**Note:** Microphone sold separately. Screws for installation are not included. For use with Alde Compact 3020 HE. For Alde Compact 3020 and Alde Compact 3010 systems installed before 2016, functionality and number of commands are limited.

## MICROPHONE FOR VOICE CONTROL SYSTEM



**Code** AL3020193

With Alde Voice Control, you can control your Alde heating system with your voice. Using various voice commands, you can set or activate different functions such as temperature and hot water to get the right temperature.

**Contents:** Microphone and USB power cable. Note: Gateway sold separately. Screws for installation are not included. Vehicles without powered USB sockets require a USB adapter. See vehicle documentation for details. For Alde Compact 3020 HE. For Alde Compact 3020 and Alde Compact 3010 before model year 2016, functionality and number of commands are limited.

## BOTTOM-FILL SERVICE PUMP



**Code** AL3020811

The Alde Bottom-fill Service Pump is an unbeatable piece of equipment when it comes to filling an Alde heating system. The portable unit allows the operator to quickly fill and bleed even the largest heating system in a matter of minutes.

## ENGINE HEAT EXCHANGER



**Code** AL2968901

The waste heat in an engine's cooling system can be used for heating the living space via Alde's engine heat exchanger and central heating system. Then all that's required is to set the desired room temperature on the control panel as normal and the central heating circulates automatically when called for.

The system can be reversed if a circulation pump (2755) is installed in the engine cooling system, allowing the engine to be pre-heated, saving the extra fuel used in cold starting.

When installing the engine heat exchanger, the vendor or vehicle manufacturer should be consulted to avoid technical mishap.

### Technical Specifications

Dimensions : L 190×W 72×H 65 mm (excl. connections)  
 Weight : 1.3 kg  
 Connection to the heating system: Ø 22 mm  
 Connection to the engine system: Ø 16 mm

## INSTALLATION OVERVIEW

### Truma S Heaters

Below you can see an example of how Truma heating systems are installed and recommended accessories.

1. Truma S series heater
2. Multi-heat added electric heater
3. Room temperature sensor for ultra heat
4. Control panel (electric heater)
5. Roof exhaust
6. Hot air pipe
7. Air separator
8. Isotherm air duct
9. Angular air outlet
10. T-piece LT
11. Insulated elbow
12. Insulated air duct
13. Airmix comfort kit (air breaker)
14. Airmix control panel
15. Multivent fan 12V
16. T piece TS
17. Elbow BG
18. Truma S 5004 flame effect cover

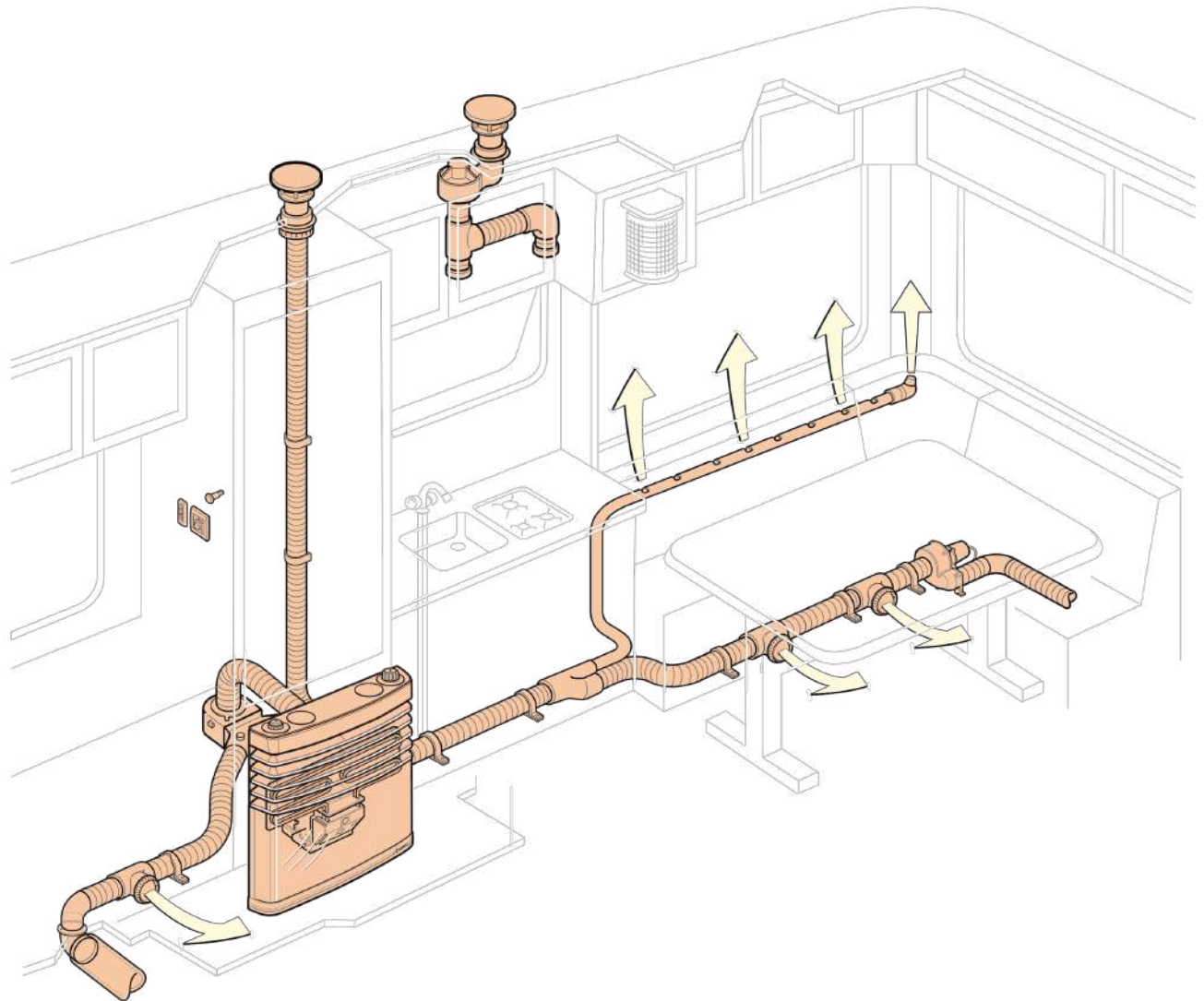

### S2200 GAS CARAVAN HEATER



<b>Code</b>	TU31110-10 Right	<b>Code</b>	TU31110-11 Left
-------------	---------------------	-------------	--------------------

With its heat output, dimensions and weight, the Truma S 2200 is the smallest and lightest Truma S heater. It was developed to generate pleasant warmth in small caravans.

Because of its compact dimensions, the Truma S 2200 can be integrated flexibly in your caravan. The gas heater is very economical and reliable. The heater comes with a 1.5V auto ignitor.

- Even distribution of the warm air
- Without a fan, can be operated independently of a power grid
- Low gas consumption
- Flue gas removed through roof or wall cowl
- Heater available with flue gas connection on the left (standard) or on the right (on request)

#### Technical Specifications

#### Technical Specifications

Power source	: Propane / Butane
Heat output	: 1850W
Working pressure	: 30 mbar
Dimensions (WxHxD)	: 420x365x120 mm
Weight	: 6.7 kg
Fuel Consumption	: 50-170 g/h
Ignition	: 1.5 V (battery-powered automatic ignition)

### S3004 GAS CARAVAN HEATER



<b>Code</b>	TU31381-01
-------------	------------

Simply switch it on for a comfortable temperature: Truma S 3004 heaters provide warmth and comfort within a very short time. The caravan and motor home heater is not only especially powerful, it is also extremely reliable – even at very low temperatures in winter. To heat your caravan even faster, the fan is equipped with a booster function.

Your caravan not only becomes warm: the interior air is also dehumidified. At night, you can switch off the fan so that you can sleep undisturbed. Truma S 3004 heaters have a modern design and are easy to operate. The S 3004 has a burner and a heat exchanger and is suitable for installation in caravans and motor homes.

- Booster function for 20% more volumetric air flow
- Ergonomic control units with non-slip surface
- Efficient, robust and low maintenance
- Heating without electricity while you're driving
- Optimum integration in the interior thanks to the flat cover
- Infinitely adjustable temperature and fan speed

#### Technical Specifications

Power source	: Propane / Butane
Heat output	: 3500W
Working pressure	: 30 mbar
Dimensions (WxHxD)	: 503x545x373 mm
Weight	: 10.3 kg
Fuel Consumption	: 30-280 g/h
Ignition	: 1.5 V (battery-powered automatic ignition)

### S5004 GAS CARAVAN HEATER



<b>Code</b>	TU31571-01 Single Fan	<b>Code</b>	TU31571-21 Double Fan
-------------	--------------------------	-------------	--------------------------

Truma S 5004 heaters are absolutely reliable and very powerful: with two burners and heat exchangers, they provide pleasant warmth in all seasons. The practical control knobs allow you to set the precise fan speed and temperature. You can achieve an average room temperature of about 22 °C without the fan – for optimum heat distribution, we recommend that you run the caravan heater with fan. This also stops the air condensing on cold surfaces. The booster function distributes the warm air very quickly and also dehumidifies your caravan.

- Faster heat distribution and dehumidification with the booster function
- Efficient, robust and low maintenance
- Many different design options, such as the flame-effect front case with flame acoustics
- The flat cover saves space
- Precise temperature setting and infinitely adjustable fan speed

#### Technical Specifications

Power source	: Propane / Butane
Heat output	: 6000W
Working pressure	: 30 mbar
Dimensions (WxHxD)	: 533x568x496 mm
Weight	: 17.5 kg
Fuel consumption	: 60-480 g/h
Optional	: Fan and distribution channels
Ignition	: 1.5 V (battery-powered automatic ignition)

## INSTALLATION OVERVIEW

Below you can see an example of how the Truma Vario Heat system is installed and the recommended accessories.

1. Vario Heat Eco / Comfort
2. Vario Heat control panel
3. Truma inet box
4. Truma App
5. Heat sensor
6. Double entry control wiring box
7. Truma E-Kit
8. Side wall exhaust (roof exhaust also available) it could be)
9. 80mm hot air pipe
10. 80mm Y piece
11. Square air outlet vent

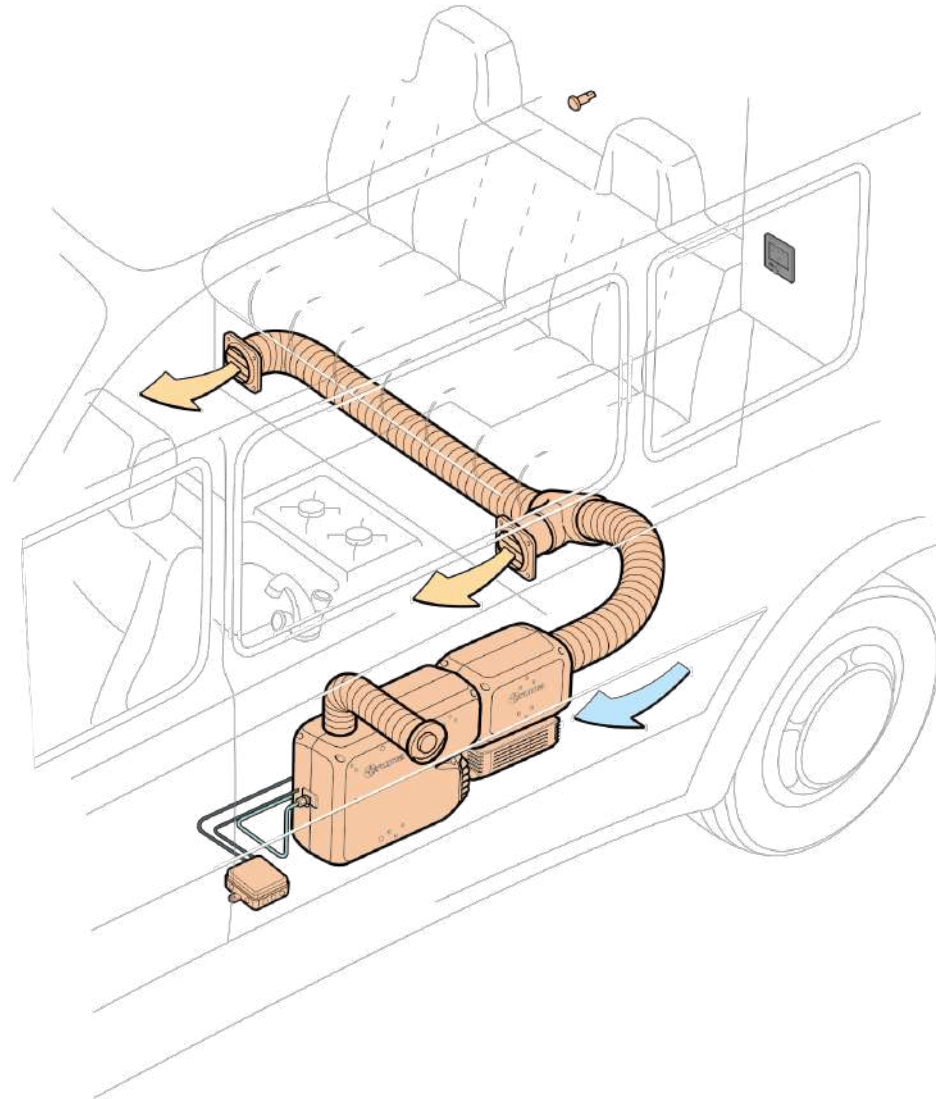

### VARIO HEAT COMFORT



**Code** TU37501-01

#### Technical Specifications

Power source : Propane / Butane  
 Gas consumption : Level 1 - 100g/h  
                           Level 2 - 220g/h  
                           Level 3 - 290g/h  
 Heat Output : Level 1 - 1300W  
                           Level 2 - 2800W  
                           Level 3 - 3700W  
 Air flow rate : Level 1 - 75m<sup>3</sup>/h  
                           Level 2 - 155m<sup>3</sup>/h  
                           Level 3 - 290m<sup>3</sup>/h  
 Gas pressure : 30 mbar  
 Weight : 5,1 kg  
 Power consumption (12V) : Level 1 - 0.65A  
   Level 2 - 2.75A  
   Level 3 - 5.4A  
 Gas burning rate : 1. 98.5% / 2. 96.3%

The Truma VarioHeat comfort is a high-performance and extremely compact heater for vans, motorhomes and caravans. It is one of the latest generation of heaters with progressive Truma technology. You can heat your vehicle quickly and reliably using the three output levels.

### VARIO HEAT ECO

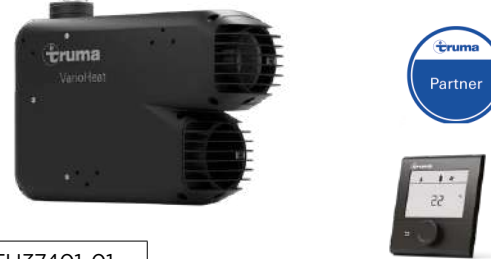

**Code** TU37401-01

#### Technical Specifications

Power source : Propane / Butane  
 Gas consumption : Level 1 - 100g/h  
                           Level 2 - 220g/h  
 Heat Output : Level 1 - 1300W  
                           Level 2 - 2800W  
 Air flow rate : Level 1 - 75m<sup>3</sup>/h  
                           Level 2 - 155m<sup>3</sup>/h  
 Gas pressure : 30 mbar  
 Weight : 5,1 kg  
 Power consumption (12v) : Level 1 - 0.65A / Level 2 - 2.75A  
 Gas burning rate : 1. 98.5% / 2. 96.3%

The Truma VarioHeat eco is an extremely compact and lightweight gas heater of the latest generation. It is very powerful and heats your vehicle to the required temperature very quickly. Thanks to the various functions, you can always set the heater to your precise requirements.

### VARIO HEAT E-KIT



**Code** TU39200-01

#### Technical Specifications

Power supply : 12/220V  
 Heat output : Level 1 - 900W  
                           Level 2 - 1800W  
 Weight : 2,2 kg  
 Power consumption (12V) : Level 1 - 3,9A / Level 2 - 7,8A

### ULTRA HEAT



**Code** TU30402-02

Truma Ultraheat is the ideal addition to S 3004 and S 5004 heaters in your caravan. The additional electric heater warms motor homes and caravans quickly and reliably. Depending on your individual warmth requirements, choose one of three operating levels: 500W, 1000W or 2000W. In-between seasons you can heat with Truma Ultraheat alone.

#### Technical Specifications

Power supply : 230 V ~ 50 Hz  
 Power consumption : 500 W: 2.2 A  
                                   1000 W: 4.5 A  
                                   2000 W: 8.5 A  
 Weight : 2 kg

### S 3004 RETRO COVER C



**Code** TU30090-95600  
 Titanium Gray

Front panel for S3004

**S 3004 + FRONT PANEL**



**Code** TU30110-01  
Titanium Gray

Chrome-applied front panel with chrome-plated gas control panel illuminated by proximity sensor (only for S 3004)

**Note:** When ordering the stove, please order according to the front panel code you want to receive.

**S 5004 + FRONT PANEL**



**Code** TU30480-01  
Titanium Gray

Front panel for S 5004. Illuminated, chrome-plated gas control panel with proximity sensor, chrome application.

**S 3004 ÖN PANEL SET**



**Code** TU30420-01  
Titanium Gray

Front panel, gas control panel, front panel and top cover for S 3004.

**Note:** You can choose color to order only front panel.

**S 5004 + FRONT PANEL SET**



**Code** TU30430-01  
Titanium Gray

Front panel, gas control panel, front panel and top cover for S 5004.

**LIGHTING KIT 1**



**Code** TU30470-01

Illuminated chrome plated gas control panel with sensor board and 12 volt cable. (for S3004/S5004)

**LIGHTING KIT 2**



**Code** TU30470-02

- Chrome plated throttle control with primary switch illumination.
- Second switch chrome-plated illuminated fan control panel (for S3004/S5004)

**LIGHTING KIT 3**



**Code** TU30470-03

- Chrome plated throttle control with primary switch illumination.
- 1st fan control panel with second switch chrome plated illuminated
- Third switch chrome plated illuminated 2nd fan control panel (for S5004)



### REMOTE FIRING INDICATOR



**Code** TU30090-98200

It is applied to the cover of S5004/S3004 heaters.

### AIRMIX AIR DIRECTOR



**Code** TU40622-01

It is suitable for all truma vent fans except multivalent fans of the 05/1996 production year.

### MULTIVENT FAN TBM



**Code** TU41142-01

Truma S 2200 is integrated into the stove and used for homogeneous distribution of air flow. It can also be used as air suction and air blowing in kitchen and toilet environments.

#### Technical Specifications

Working Power : 12 V  
 Air flow rate : Half Setting 29 m<sup>3</sup>/h  
 Full Setting 60 m<sup>3</sup>/h  
 Power consumption : Half Setting 0.23 A  
 Full Setting 0.5 A

### FAN TEB-3, 12 V



**Code** TU41240-02

With automatic speed control, suitable for fan hose connection Ø 65 mm or VR Ø 72 mm.

**Fan TEB-3, external control panel**  
 1.5 m cable for S 5004 and S 3004



**Code** TU41251-01

Fan TN-3, 230 V, external control panel  
 1.5 m cable for S 5004 and S 3004

**Fan TN-3, for 230 V fan hose connection**  
 ÜR Ø 65 mm and VR Ø 72 mm

	TEB-3* (12 V)	TN-3** (230 V)
Power consumption	Ø 0.7 A (0.2-1.2 A)	Ø 0.3 A (0.2-0.5 A)
Air flow rate (free blowing without hot air duct)	149 m <sup>3</sup> /h	170 m <sup>3</sup> /h
Air flow rate (2x3 m hot air duct uninsulated) Ø 65 mm	104 m <sup>3</sup> /h	137 m <sup>3</sup> /h
	VR Ø 72 mm	154 m <sup>3</sup> /h
Weight	1.1 kg	1.7 kg

\* Up to 20% stronger than TEB-2 in long-insulated hot air systems

\*\* Up to 5% more powerful than TN-2 in long-insulated hot air systems



## INSTALLATION OVERVIEW

Below you can see an example of how Truma BOILER systems are installed and recommended accessories

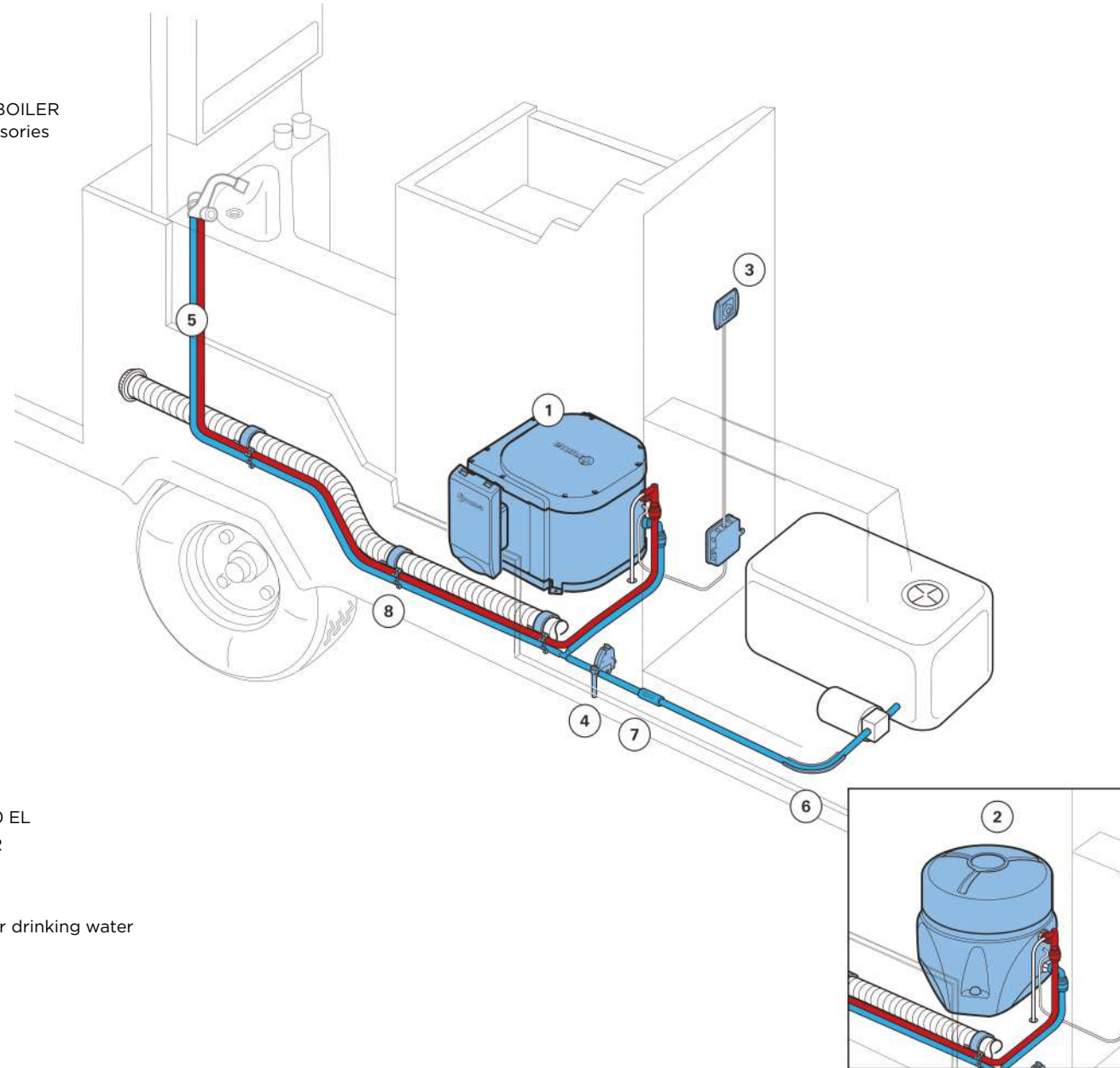

1. Truma BOILER B10/B10 EL
2. Truma Electric BOILER
3. Control panel
4. Frost control
5. Water hose suitable for drinking water
6. Hose corner guide
7. Check valve
8. Hose clip

**BOILER B10 (GAS)**



**Code** TU73601-20

In the Truma boiler (gas), a powerful gas burner heats the water in your caravan or motor home quickly - completely without a power supply. The gas boiler has excellent insulation to ensure that almost no heat is lost. If the water temperature drops, the electronics reignite automatically. Set the desired water temperature anywhere between 30°C and 70°C with the control unit.

**Technical Specifications**

Heating time approximately : 30 dk  
 Maximum temperature : 70 C°  
 Ignition : 12 V  
 Power source : Propane / Butane  
 Gas pressure : 30 mbar  
 Water working pressure : Max 2.8 bar  
 Thermostat : Var  
 Internal Volume : 10 litre  
 Fuel consumption : 120 g / h  
 Dimensions (WxHxD) : 350x320x350 mm  
 Weight : 6.9 kg (su hariç)  
 ID numarası : CE-0085AP0038  
 Water connection : Pressurized hot water hose,  
 10 mm - 12 mm for rigid pipes

**BOILER B10 EL (GAS AND ELECTRIC)**



**Code** TU73611-20

The gas/electric boiler also has an electric heating element that heats the water even faster. It reduces heating up time from 30 minutes in gas mode to 15 minutes in mixed mode - for example, when heating water from 15°C to 70°C.

When the water is hot, you can take a long shower with ample time to soap yourself. When the Truma gas boiler is running, water is continuously reheated while you are showering. This means that a second person can shower immediately afterwards.

- Insulation prevents heat loss
- Additional electric heating element (optional)
- High pressure resistance of the Truma gas water heater (all submersible and pressure pumps up to 2.8 bar can be used)
- Safety ensured with electronic control components and overpressure valve
- Stainless steel container



**Code** TU70400-01



**Code** TU70400-02

**Technical Specifications**

Heating time electric : 29 dk  
 Heating time electricity/gas : 16 dk  
 Maximum temperature : 70 C°  
 Ignition : 12 V  
 Power supply : Propan / Bütan / 220V  
 Power consumption (220V) : 3.7A 850W / 5.7A 1300W  
 Gas pressure : 30 mbar  
 Water pressure : Max 2.8 bar  
 Thermostat : Var  
 Internal Volume : 10 litre  
 Fuel consumption : 120 g / h  
 Dimensions (WxHxD) : 350x320x350 mm  
 Weight : 7.4 kg (su hariç)  
 ID numarası : CE-0085AP0038  
 Water connection : Pressurized hot water hose,  
 10 mm - 12 mm for rigid pipes

## THERME TT (ELECTRIC)

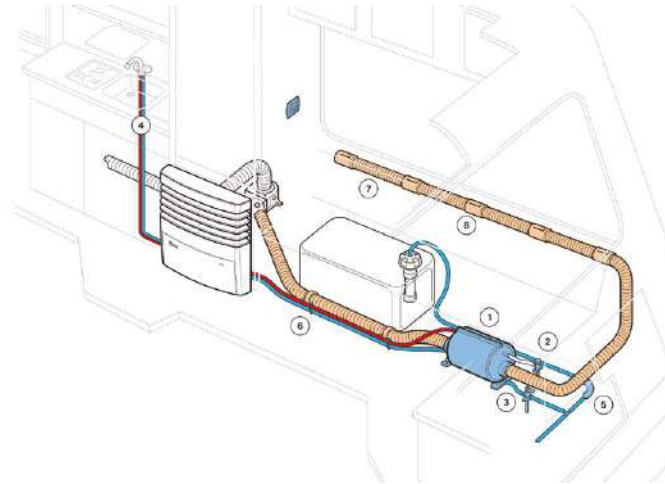

**Code** TU42014-01



The Truma Therme for caravans uses existing warmth from the heater to heat water. A warm air pipe runs directly through the appliance and releases heat to the water. This is especially useful on cooler days in spring and autumn to have hot water at all times – for example, to wash your hands or brush your teeth. When the heater is not in use, an electric heating element ensures that the water is heated quickly and efficiently.

Switch the Truma Therme on with the control unit. The control light indicates that the appliance is operating. A thermostat regulates the water temperature to 65°C. Adjust the water temperature to your needs with the mixing tap or the pre-mixing valve. The excellent materials used ensure the drinking quality of the water.

- Short heating time in electric mode
- Can be used with all regular submerged pumps to a maximum of 1.2 bar
- Includes control panel, drain and aeration valve (without mixing valve)

1. Truma therme
2. Ventilation valve
3. Drain valve
4. Water hose suitable for drinking water
5. Hose corner guide
6. Hose clip
7. 65mm hot air duct
8. Wall socket vent

### Technical Specifications

Heating time	: Approximately 50 min.
Maximum temperature	: 65 C°
Power supply	: 220V
Power consumption	: 1,3A (300W)
Water pressure	: Max 1.2 bar
Thermostat	: Yes
Internal Volume	: 5 liters
Fuel consumption	: 220V/1.3 A
Dimensions (WxHxD)	: 370x220x230 mm
Weight	: 2 kg (excluding water)
ID numarası	: CE-0085AP0038
Water connection	: Pressurized hot water hose, 10 mm - 12 mm for rigid pipes

## DOUBLE CONNECTION DRAIN VALVE



**Code** TU40020-00900

Truma Therme double port relief valve

## MIXING VALVE



**Code** TU40020-00900

For Truma Therme

## WATER DRAIN VALVE



**Code** TU40020-00900

1.5 bar Truma Therme's central water supply (city connection)

**ELEKTROBOILER (ELECTRIC)**



**Code** TU71201-01

The Truma electric water heater heats the water in your caravan or motor home quickly and keeps it hot for a long time. This allows you to wash your hands thoroughly, wash dishes and even take a long shower at any time: the high quality stainless steel container with extra-large capacity makes this possible. The Truma electric boiler consumes little electricity and operates almost silently.

The boiler is insulated with a special expanded polypropylene (EPP) foam. This lightweight material has optimum thermal insulation properties. The water temperature drops by just 1°C per hour and reheating takes next to no time, despite the size of the water tank. The stainless steel container and all other materials that come into contact with water are safe for use with drinking water.

- Quick and easy installation
- For pressure-resistant hot water hoses with 10 mm diameter
- For city water systems to max. 2.8 bar (from 2.8 bar in combination with a pressure reducer)

**Technical Specifications**

Heating time	: Approximately 50 min.
Maximum temperature	: 70 C°
Power supply	: 220V
Water pressure	: Max 2.8 bar
Thermostat	: Yes
Internal Volume	: 14 liters
Fuel consumption	: 220V/3.7 A
Dimensions (WxHxD)	: 405x295x205 mm
Weight	: 3 kg (excluding water)

**DRAIN VALVE BO TB**



**Code** TU70141-02

For Ø 10 mm flexible hoses



**Code** TU70142-05

With Ø 12 mm connection for rigid pipe (John Guest system)



**Code** TU70400-01



**Code** TU70400-02

**FROST CONTROL KIT TB**



**Code** TU34020-00237

Truma frost control  
If your water heater is at risk of freezing, it will automatically drain the water from the boiler. Relief valve for pressurized water systems up to 2.8 bar. For Ø 10 mm flexible hoses.

**FROST CONTROL KIT JG**



**Code** TU34020-00238

Truma frost control  
If your water heater is at risk of freezing, it will automatically drain the water from the boiler. Relief valve for pressurized water systems up to 2.8 bar. For Ø 10 mm flexible hoses.



# GAS SYSTEMS

GAS MEASUREMENT DEVICES

REGULATORS

GAS VALVES AND HOSES

ACCESSORIES





## LEVELCONTROL GAS LEVEL CONTROLLER



**Code** TU50700-01

### Make life easier: Truma LevelControl

If you prefer to hold your smartphone instead of tilting the gas cylinder, you're in luck because LevelControl allows you to do just that. The gas level meter uses ultrasound to measure how much gas is left in your cylinder and displays the result in the app. Attach LevelControl to the bottom of the cylinder, open the app, check the gas level - it couldn't be easier!

The new LevelControl App also gives you the option to use Bluetooth to control the gas level. This works conveniently and reliably in and out of the vehicle when in range. If you want to check the gas level while travelling, you'll need the Truma iNet Box and the tried and tested Truma App. Whether you're skiing at home or out on the slopes, it sends the measurement results to your smartphone as a text. Truma iNet Box also allows you to connect other devices, such as Truma heaters and air conditioners, to the iNet System and operate them using the Truma App.

- Notification when gas level is low
- Use several LevelControls at the same time
- Magnetically adheres to any steel cylinder - and also adheres to aluminum cylinders thanks to a clamping plate
- Works with all existing European gas cylinders - simply select the model from the comprehensive database
- LevelControl is not suitable for plastic gas cylinders, refillable gas cylinders, gas tanks or butane gas cylinders (camping gas).

- LevelControl won the 2018 European Innovation Award in the General Concept Equipment category.
- Install Truma LevelControl under your gas cylinder. No assembly, no wiring. Open the app - done!

**Truma LevelControl App:** Control gas level via Bluetooth.

### Truma Application:

Check the gas level via text message, even while traveling. Connect other Truma devices such as heaters and air conditioners to the iNet System

**Requirement:** Truma iNet Box



## LEVELCONTROL HOLDER



**Code** TU50901-01

Holder for attaching the Truma LevelControl gas level indicator (non-magnetic) to aluminum gas bottles. Not suitable for metal gas bottles or plastic gas bottles.

## LEVELCHECK GAS LEVEL METER



**Code** TU50501-01

Use LevelCheck to find out how much gas is left in the gas cylinder in just a few seconds. Using ultrasound, the handy filling level indicator shows whether there is liquefied gas within the measuring range. Simply place LevelCheck horizontally on the cylinder: if the LED is green, there is gas in the cylinder. After measuring, LevelCheck switches off automatically.

The filling level display for gas cylinders is suitable for much more than just the camp site or barbecue. You can also use LevelCheck to check the level of the cylinder for the gas hob or wok burner in your kitchen. This handy device will also ensure that you are not stranded without gas for your DIY projects. By the way: to ensure reliable measurement, we advise that you clean the measuring head regularly with a damp cloth.

- Measures in a temperature range of -15 to +40 degrees Celsius
- Not suitable for plastic gas cylinders, refillable gas cylinders, gas tanks or butane cylinders (Campingaz)
- Measures quickly and reliably in just a few seconds
- Easy to use, with LED display, ready to use immediately
- Suitable for all steel and aluminium LPG cylinders with diameters of 200 to 350 mm
- Lightweight but sturdy
- Integrated LED torch for checking gas in the dark



**Protect your gas system from contamination**

Depending on the LP gas you use, it may contain oily substances such as olefins, paraffins, or other hydrocarbon compounds that flow with the gas. They settle in gas pressure regulation systems, hoses, piping systems, valves and gradually clog them.

Truma gas filters feature an efficient, patent-protected filter cartridge, providing effective protection against contamination. Separates 99% of oily particles. By comparison, we can say that traditional paper filters can filter only 30%. Truma gas filters are installed between the gas pressure regulator and gas hoses. Suitable for single and two cylinder gas pressure regulation systems. The gas filter is easy to replace. Supports the superior functional reliability and durability of your gas system.

Installation Example

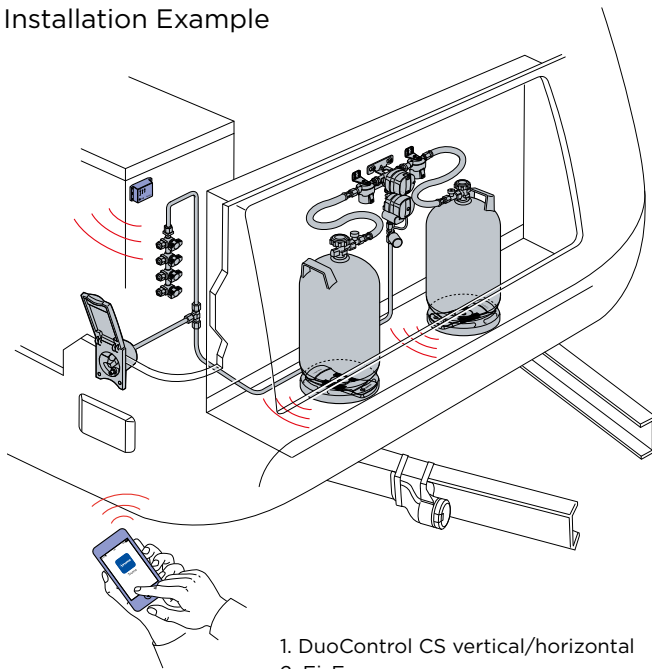

1. DuoControl CS vertical/horizontal
2. EisEx
3. Gas filter
4. Truma gas hose
5. Gas on/off control for safety
6. Copper pipe
7. 4 outlet valve
8. Barbecue gas outlet (BBQ point)
9. Truma iNet Box
10. Truma LevelControl
11. Truma Application



## Safe heating on the go

How safe is it to run a gas system to keep you warm while you're on the go? Truma has had an answer for this for years. We have reached further technical standards to develop protective devices to allow you to stay warm while driving and have now combined the collision sensor with our next generation gas pressure regulation systems. This sensor responds even to accidents at effective speeds lower than 15-20 km/h. It cuts off the gas supply without damaging lines and devices. Thus, you and everyone traveling with you can safely reach wherever you want to go, feeling comfortable and safe. Truma gas pressure regulation systems offer you everything you need for safe heating on the move throughout Europe.

## Advantages at a glance

- Maximum security level
- Complies with all European standards and regulations
- Easy to install and operate
- No power consumption
- Designed for single and double cylinder gas systems.
- There is no pressure loss thanks to additional parts and apparatus.
- Compatible with original Truma accessories and control panels produced by many manufacturers.



## Important information

**When using a caravan, since vehicles built after 01/2007 run on liquid gas, if the line is broken due to an accident, a safe shut-off device must be installed to prevent gas leakage, according to the current European heating devices directive. The corresponding instructions of the caravan manufacturer must be followed before operating the liquid gas appliance while driving.**

## Crash sensor

- Our pressure adjustment systems accompany the collision sensor. You will be safe everywhere. Even if you want to operate the gas system on your moving vehicle.
- Complies with European standards and regulations.
- It secures the gas system by cutting off the gas even in collisions at 15 km/h.
- Immediately shuts off gas before lines and devices suffer damage.

## MONOCONTROL CS DİKEY (REGÜLATÖR)



**Code** TU52410-01

### Technical Specifications

Gas type	: Propane / Butane
Inlet pressure	: 0.3/16 bar
Output pressure	: 30 mbar
Regulator capacity	: 1.5 kg/saat
Input connection	: m 20x1.5
Output connection	: 10 mm/8 mm
Lock sensor activation value:	4.0 g +/- 1.0 g
Ölçü (GxYxD)	: 101x106x102 mm
Weight	: Approx 500 gr

The new generation Truma MonoControl CS is a gas pressure regulator with integrated crash sensor, which is suitable for a single gas cylinder. The sensor ensures that you can also heat your caravan or motor home safely while you're on the road. Should you be involved in an accident with a collision speed of about 15 to 20 km/h against a solid object, the crash sensor stops the gas flow immediately. If the gas system is damaged, no gas can escape. The MonoControl CS gas pressure regulator is also ideal for stationary operation at campsites.

- Easy to see if the crash sensor has been triggered and easy to reset
- Lightweight
- Quick to install

## MONOCONTROL CS YATAY (REGÜLATÖR)



**Code** TU52420-01

### Technical Specifications

Gas type	: Propane / Butane
Inlet pressure	: 0.3/16 bar
Output pressure	: 30 mbar
Regulator capacity	: 1.5 Kg/saat
Input connection	: m 20x1.5
Output connection	: 10mm/8mm
Lock sensor activation value:	4.0 g +/- 1.0 g
Weight	: Approx 500 gr

The new generation Truma MonoControl CS is a gas pressure regulator with integrated crash sensor, which is suitable for a single gas cylinder. The sensor ensures that you can also heat your caravan or motor home safely while you're on the road. Should you be involved in an accident with a collision speed of about 15 to 20 km/h against a solid object, the crash sensor stops the gas flow immediately. If the gas system is damaged, no gas can escape. The MonoControl CS gas pressure regulator is also ideal for stationary operation at campsites.

- Easy to see if the crash sensor has been triggered and easy to reset
- Lightweight
- Quick to install

## DUOCONTROL CS DİKEY (REGÜLATÖR)



**Code** TU51611-01

### Technical Specifications

Gas type	: Propane / Butane
Inlet pressure	: 0.6/16 bar
Output pressure	: 30 mbar
Regulator capacity	: 1.5 kg/saat
Input connection	: m 20x1.5
Output connection	: 10 mm / 8 mm
Lock sensor activation value:	4.0 g +/- 1.0 g
Weight	: Approx 900 gr

You can connect two gas cylinders in your motor home or caravan to the new generation of Truma DuoControl CS gas pressure regulators. The system automatically switches over to the second gas cylinder when the operating cylinder is empty. The integrated crash sensor allows you to heat your vehicle safely while you're driving. It prevents gas escaping should you be involved in an accident.

- Easy to see if the crash sensor has been triggered and easy to reset Shows which cylinder is in use and, consequently, if it is full or empty
- Automatically switches over from the empty cylinder to the full one
- Lightweight
- Quick to install
- Available as vertical and horizontal versions

## DUOCONTROL CS HORIZONTAL (REGULATOR)



**Code** TU51621-01

### Technical Specifications

Gas type	: Propane / Butane
Inlet pressure	: 0.6/16 bar
Output pressure	: 30 mbar
Regulator capacity	: 1.5 kg/saat
Input connection	: m 20x1.5
Output connection	: 10 mm / 8 mm
Lock sensor activation value	: 3.5g+/-0.5g
Weight	: Approx 900 gr

You can connect two gas cylinders in your motor home or caravan to the new generation of Truma DuoControl CS gas pressure regulators. The system automatically switches over to the second gas cylinder when the operating cylinder is empty. The integrated crash sensor allows you to heat your vehicle safely while you're driving. It prevents gas escaping should you be involved in an accident.

- Easy to see if the crash sensor has been triggered and easy to reset Shows which cylinder is in use and consequently, if it is full or empty
- Automatically switches over from the empty cylinder to the full one
- Lightweight
- Quick to install
- Available as vertical and horizontal versions

## GAS CONTROL PANEL



**Code** TU57014-01

### Technical Specifications

Special characteristic	: Suitable for single or double gas cylinder
Energy power	: 12V
Power consumption	: 40mA

- Thanks to the gas remote control, you can easily open and close the gas tank from inside your vehicle.
- 8 mm or 10 mm options are available depending on the thickness of your gas hose

## GAS FILTER SPARE CARTRIDGE



**Code** TU50680-01

Consult your technical services about the replacement times for the replacement cartridges of your old version 94 mm gas filter kits that you use in your caravans.

## GAS FILTER SET



**Code** TU50603-01  
Gas Filter

The Truma gas filter effectively protects the gas system from contamination in gas cylinders. Oily particles are carried along with the gas flow as aerosols, depositing themselves in the regulators and blocking them. The new generation of Truma gas filters removes these residues from the gas and deposits them on a filter pad which is easy to replace when the cylinder is replaced.

As opposed to the predecessor model, it is no longer necessary to replace the filter cartridge. Consequently, the Truma gas filter ensures that the gas system and all gas-operated appliances will have a long service life.

- Can be opened only when the gas cylinder is closed
- Quickly retrofitted, suitable for all wall and ceiling-mounted Truma gas pressure regulators
- Filters up to 99.9% of aerosols and protects the gas system and all gas appliances
- Use filter together with the pads for longer and save money
- Fits in all gas cylinder boxes
- Can be opened quickly without tools to check and replace the pad

**Code** TU50681-01  
Gas Filter Pad



The Truma gas filter effectively protects the gas system from impurities: Oily residues are reliably filtered out of the gas stream and deposited in the filter element. Then you can change this pad when you change the tube.

- In Europe, it needs to be replaced every 6 months.

## SINGLE GAS VALVE



**Code** TU23112-31

**Code** TU23211-31

### Technical Specifications

Input : 8 mm  
Output : 8 mm

### Technical Specifications

Input : 8 mm  
Output : 10 mm

**Code** TU23131-31

### Technical Specifications

Input : 10 mm  
Output : 10 mm

- Thanks to manifold valves, you can distribute equal amounts of gas to different types of devices in your vehicle from a single point.
- In case of emergency gas cut-off, you can easily understand which valve belongs to which device with the easy-to-move valves and the sticker on the valve.
- With manifold valves, you can easily distribute gas from a single central point without the need for T or Y connections.

## DUAL GAS VALVE



**Code** TU24115-31

### Technical Specifications

Input : 2x8 mm  
Output : 2x8 mm

- Thanks to manifold valves, you can distribute equal amounts of gas to different types of devices in your vehicle from a single point.
- In case of emergency gas cut-off, you can easily understand which valve belongs to which device with the easy-to-move valves and the sticker on the valve.
- With manifold valves, you can easily distribute gas from a single central point without the need for T or Y connections.

## DUAL GAS VALVE



**Code** TU24116-31

### Technical Specifications

Input : 2x10 mm  
Output : 2x8 mm

- Thanks to manifold valves, you can distribute equal amounts of gas to different types of devices in your vehicle from a single point.
- In case of emergency gas cut-off, you can easily understand which valve belongs to which device with the easy-to-move valves and the sticker on the valve.
- With manifold valves, you can easily distribute gas from a single central point without the need for T or Y connections.

## TRIPLE GAS VALVE



**Code** TU24135-31

### Technical Specifications

Input : 3x8 mm  
Output : 3x8 mm

- Thanks to manifold valves, you can distribute equal amounts of gas to different types of devices in your vehicle from a single point.
- In case of emergency gas cut-off, you can easily understand which valve belongs to which device with the easy-to-move valves and the sticker on the valve.
- With manifold valves, you can easily distribute gas from a single central point without the need for T or Y connections.

## TRIPLE GAS VALVE



**Code** TU24136-31

### Technical Specifications

Input : 3x10 mm  
Output : 3x8 mm

- Thanks to manifold valves, you can distribute equal amounts of gas to different types of devices in your vehicle from a single point.
- In case of emergency gas cut-off, you can easily understand which valve belongs to which device with the easy-to-move valves and the sticker on the valve.
- With manifold valves, you can easily distribute gas from a single central point without the need for T or Y connections.

### QUADRUPLE GAS VALVE



**Code** TU24155-31

#### Technical Specifications

Input : 4x8 mm  
Output : 4x8 mm

- Thanks to manifold valves, you can distribute equal amounts of gas to different types of devices in your vehicle from a single point.
- In case of emergency gas cut-off, you can easily understand which valve belongs to which device with the easy-to-move valves and the sticker on the valve.
- With manifold valves, you can easily distribute gas from a single central point without the need for T or Y connections.

### QUADRUPLE GAS VALVE



**Code** TU24156-31

#### Technical Specifications

Input : 4x10 mm  
Output : 4x8 mm

- Thanks to manifold valves, you can distribute equal amounts of gas to different types of devices in your vehicle from a single point.
- In case of emergency gas cut-off, you can easily understand which valve belongs to which device with the easy-to-move valves and the sticker on the valve.
- With manifold valves, you can easily distribute gas from a single central point without the need for T or Y connections.

### GAS HOSE



**Code** TU50615-08

#### Technical Specifications

Length : 1 meter

BBQ is a hose suitable for external gas intake.  
Made of high quality and durable

### GAS HOSE

**Code** TU50615-01

#### Technical Specifications

Input çapı : 8 mm  
Output çapı : 8 mm  
Length : 40 cm

**Code** TU90651-01

#### Technical Specifications

Input çapı : 10 mm  
Output çapı : 10 mm  
Length : 40 cm

- High pressure hoses that are safe against hose ruptures
- Products with hose rupture protection provide high safety even while on the move
- Truma high pressure hoses meet the requirements of all relevant regulations

### HIGH PRESSURE HOSE

Gerilme sonucu oluşan yırtıklara karşı korumalı (HRP)



**Code** TU50415-01  
Gas Hose  
Length: 450 mm

**Code** TU50425-01  
Gas Hose  
Length: 750 mm



**Code** TU50415-04  
Gas Hose  
Length: 450 mm

**Code** TU50425-04  
Gas Hose  
Length: 750 mm



**Code** TU50415-02  
Gas Hose  
Length: 450 mm

**Code** TU50425-02  
Gas Hose  
Length: 750 mm



**Code** TU50415-05  
Gas Hose  
Length: 450 mm

**Code** TU50425-05  
Gas Hose  
Length: 750 mm



**Code** TU50415-03  
Gas Hose  
Length: 450 mm

**Code** TU50425-03  
Gas Hose  
Length: 750 mm



**Code** TU50415-06  
Gas Hose  
Length: 450 mm

**Code** TU50425-06  
Gas Hose  
Length: 750 mm

## MANEUVOURING SYSTEMS

Maneuvering systems allow you to maneuver your caravan wherever you want, even in the narrowest places.





**TRUMA MOVER SMART A4**

**NEW**



**Code** TU61740-01

The Mover smart A4 is Truma's low-cost, fully automatic manoeuvring aid - with proven quality. The drive rollers are swivelled onto the tyres at the touch of a button - without any muscle power! The rest is done with the remote control: you use it to manoeuvre the caravan. The soft start function ensures that the caravan starts without jerking and stops with millimetre precision. The caravan is braked as soon as you release the control buttons.

Truma Mover smart A4 - leaves competing devices standing

- Handle slopes of up to 10 per cent
- Increased operational safety thanks to automatic stop function
- Smooth and gentle parking thanks to remote control and soft-start function

**Technical Data**

- Power supply : 12 V
- Maximum power consumption : 125 A
- Quiescent current consumption : < 20 mA
- Average power consumption : 35 A / 2000 kg
- Remote control for maneuvering : Included
- Weight : Approx. 32 kg

**MOVER SMART A**



**Code** TU61730-01

The Mover smart A is the affordable, fully automatic manoeuvring assistant from Truma - and all with tried-and-tested quality. The drive rollers engage on the tyres at the push of a button - with no physical effort required! The rest is done by remote control: You can use this to manoeuvre the caravan smoothly, sensitively and with precision.

The soft-start function means that the caravan starts off without jerking and comes to a stop with millimetre precision. As soon as you release the control knobs, the caravan's brakes are applied.

**What the Mover smart A can do:**

- Copes with inclines of 13 percent
- Simple, accurate coupling to the towing vehicle
- Suitable for single-axle caravans up to 2000 kg
- The drive rollers are made of aluminium and are particularly light yet robust. They grip onto the tyre without slipping and ensure optimal transmission of the drive force.

**Technical Specifications**

- Maximum load capacity : 2000 kg
- Power supply : 12V
- Weight : 32kg
- Number of vehicle axles : Single axle
- Maximum power consumption : 125 A

**MOVER SMART M**



**Code** TU61720-01

The Truma Mover smart M is the semi-automatic entry-level model among the Truma manoeuvring assistants. It impresses with its unbeatable price/performance ratio and highest Truma quality. The drive rollers are engaged on the tyres by hand with just one lever movement - and you're already good to go!

With the remote control, you can control your caravan intuitively at the push of a button. Thanks to the soft-start function, the caravan starts off without jerking, and only then is the speed increased. As soon as you release the control knobs, the caravan's brakes are applied. This guarantees maximum safety.

**What the Mover smart M can do:**

- Copes with inclines of 13 percent
- Simple, accurate coupling to the towing vehicle
- Suitable for single-axle caravans up to 1800 kilograms
- The non-slip surface of the drive rollers ensures the required grip on the tyre and enables optimal power transmission. The rollers are particularly low-wearing yet also light - made possible by the use of cast aluminium.

**Technical Specifications**

- Maximum load capacity : 1800 kg
- Weight : 33kg
- Power supply : 12V
- Number of vehicle axles : Single axle
- Maximum power consumption : 100 A

In the graphic below, you can see information about how Truma maneuvering systems are installed and what accessories we recommend for you.

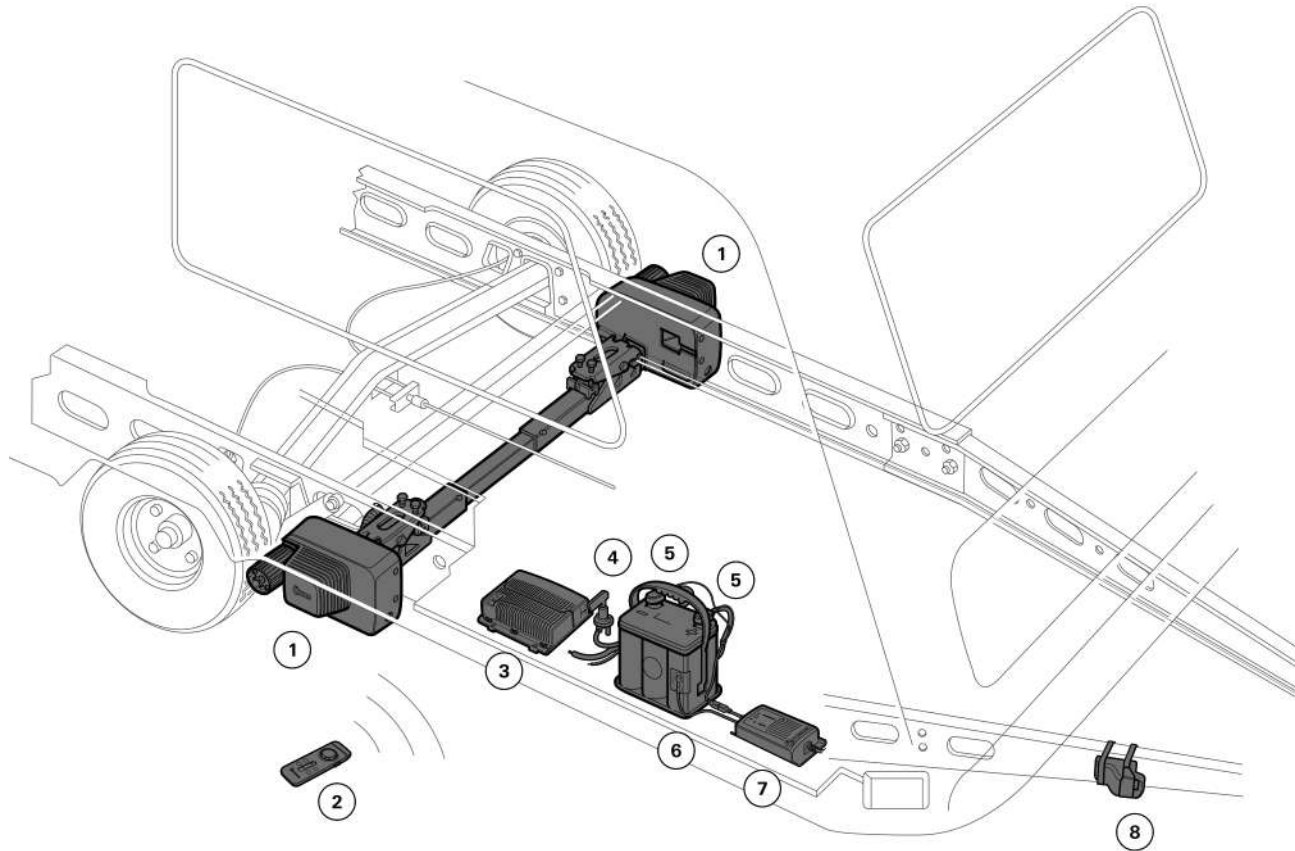

- |                   |                        |
|-------------------|------------------------|
| 1. Mover XT       | 5. Pole clamps         |
| 2. Remote control | 6. Temperature sensors |
| 3. Control panel  | 7. Battery charger     |
| 4. Fuse panel     | 8. Security socket     |

**TRUMA MOVER SMART**



You can use it in rugged areas where you have difficulty entering, in places that are not suitable for comfortable maneuvering, and on the worst surfaces you would not want to step on. The Mover maneuvering systems allow you to maneuver your caravan wherever you want, even in the narrowest places. Move your caravan over any terrain with pinpoint accuracy.

**Advantages:**

- Park your caravan with millimeter accuracy.
- Maneuver comfortably with the remote control without much effort.
- Works easily on any terrain – be it snow or sand.
- Safe handling on terrains with slopes up to 25%.
- Easily overcomes obstacles.

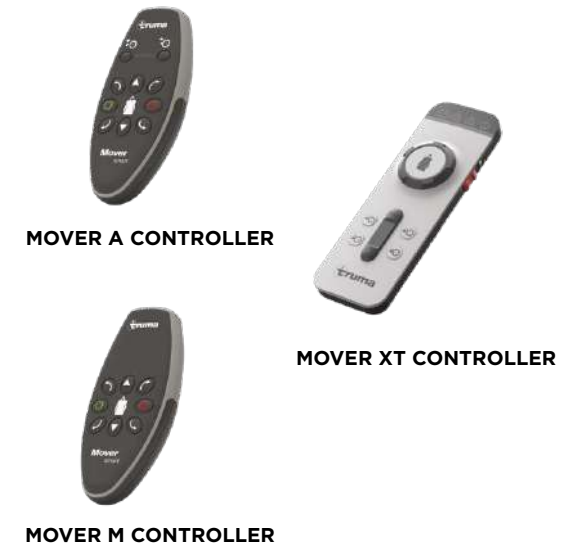

<b>Code</b>	TU61110-01 <b>Mover XT</b> For single axle caravans up to 2300 kg
<b>Code</b>	TU61210-01 <b>Mover XT2</b> For double axle caravans up to 2400 kg
<b>Code</b>	TU61310-01 <b>Mover XT4</b> For double axle caravans up to 3100 kg
<b>Code</b>	TU61110-02 <b>Mover XT L</b> For single axle caravans up to 1500 kg

	Mover XT	Mover XT2	Mover XT4	Mover XT L	Mover Smart M	Mover Smart A	Mover Smart A4
Max. climbing capacity	13% (2300 kg)	10% (2400 kg)	10% (3100 kg)	20% (1500 kg)	13% (1800 kg)	13% (2000 kg)	10% (2800kg)
Operating voltage	12 V	12 V	12 V	12 V	12 V	12 V	12 V
Maximum power consumption	150 A	150 A	150 A	150 A	100 A	125 A	125 A
Average power consumption on even ground at a total weight of	28 A <sup>1)</sup> 1700 kg	28 A <sup>1)</sup> 2000 kg	37 A <sup>1)</sup> 2800 kg	28 A <sup>1)</sup> 1500 kg	28 A <sup>1)</sup> 1800 kg	35 A <sup>1)</sup> 2000 kg	28 A 1800 kg
Maximum speed	18.5 km/min	18.5 km/min	18.5 km/min	18.5 km/min	9 km/min	9 km/min	-
Weight	28 kg	28 kg	60 kg	28 kg	33 kg <sup>2)</sup>	32 kg <sup>2)</sup>	64 kg

## BIKE RACKS

Add freedom to your freedom.



# BIKE RACKS

No matter which vehicle you have and regardless the type and number of bikes you want to take along, there is a Thule bike rack that perfectly matches your needs and that will exceed your expectations.



## Bicycle racks for motorhomes

- Can be mounted on the rear wall of the vehicle.
- Wide range of fixing systems available, developed and approved together with caravan manufacturers.
- Electric bike is portable.



## Bicycle racks for caravans

- Can be mounted on the rear wall of the vehicle.
- Wide range of fixing systems available, developed and approved together with caravan manufacturers.
- Electric bike is portable.



## Bike racks for van

- Can be mounted on the rear door of the vehicle.
- Doors can be opened by bicycle.
- It is possible to carry an electric bicycle.

**Thule Lift V16**



<b>Code</b>	TH307368 Manual
<b>Code</b>	TH307369 Motorized - 12V



2 bikes can be increased to 3.  
 Max. bike weight : 30 kg  
 Max. loadable weight: 50 kg  
 Lockable platform : Manual  
 Bicycle holder : Integrated key locks  
 Weight : 17 kg / 18.1 kg

**Thule Excellent**



<b>Code</b>	TH309821 Grey
<b>Code</b>	TH302033 Black - 12V
<b>Code</b>	TH309822 Short Grey



It can be increased up to 4. 2 bikes  
 Max. bike weight : 30 kg  
 Max. loadable weight : 60 kg  
 Right and left sliding rails  
 Lockable platform : Automatic  
 Bicycle holder : Integrated key locks  
 Weight : 10.6 kg

**Thule Elite G2**



<b>Code</b>	TH306560 Standard
<b>Code</b>	TH306561 Short



It can be increased up to 4. 2 bikes  
 Max. bike weight : 30 kg  
 Max. loadable weight : 60 kg  
 Right and left sliding rails  
 Lockable platform : Manual  
 Bicycle holder : Optional key locks  
 Weight : 9.5 kg / 10.1 kg



**Thule Sport G2**



<b>Code</b>	TH307126 Standard
<b>Code</b>	TH307127 Short

2 bikes, expandable to 3  
 Max. bike weight : 19 kg  
 Max. loadable weight : 50 kg

Right and left sliding rails  
 Lockable platform : Manual  
 Bicycle holder : Optional key locks  
 Weight : 7.9kg / 8.2kg

**Thule Sport G2 Tour**



<b>Code</b>	TH306572
-------------	----------

2 bikes can be increased to 3.  
 Max. bike weight : 19 kg  
 Max. loadable weight : 50 kg

Right and left sliding rails  
 Lockable platform : Manual  
 Bicycle holder : Optional key locks  
 Weight : 6.8 kg

**Thule Sport G2 Hobby**



<b>Code</b>	TH307128
-------------	----------

2 bikes can be increased to 3.  
 Max. bike weight : 19 kg  
 Max. loadable weight : 50 kg

Right and left sliding rails  
 Lockable platform : Manual  
 Bicycle holder : Optional key locks  
 Weight : 6.8 kg

**Thule Sport G2 Universal**



<b>Code</b>	TH306563
-------------	----------

2 bikes  
 Max. bike weight : 19 kg  
 Max. loadable weight : 38 kg

Right and left sliding rails  
 Lockable platform : Manual  
 Bicycle holder : Optional key locks  
 Weight : 8 kg

**Thule VeloSlide**



**Code** TH302014

2 bikes  
 Max. bike weight : 35kg  
 Max. loadable weight: 70 kg  
 Bicycle holder : Optional key locks  
 Weight : 20kg

**Thule Sport G2 Garage**



**Code** TH306574



2 bikes, expandable up to 4  
 Max. bike weight : 19 kg  
 Max. loadable weight : 50 kg  
 Right and left sliding rails  
 Bicycle holder : Optional key locks  
 Weight : 5.6kg

**Thule Elite Van XT**



**Code** TH307340  
 Grey  
**Code** TH302013  
 Black - 12V  
 For Ducato, Jumper and  
 Boxer after 2007

**Code** TH302018  
 Black  
 For VW crafter  
 after 2017



2 bikes  
 Max. bike weight : 19 kg  
 Max. loadable weight : 35 kg  
 Lockable platform : Manual  
 Bicycle holder : Optional key  
 locks  
 Weight : 10.5kg





## FRAME-MOUNTED BIKE RACKS

### Thule Caravan Superb



<b>Code</b>	TH307130 Standard
<b>Code</b>	TH307329 Short (2 bikes)



2 bikes can be increased to 3.  
 Max. bike weight : 30 kg  
 Max. loadable weight: 60 kg  
 Lockable platform : Manual  
 Bicycle holder : Integrated key locks  
 Weight : 9.7 kg

### Thule Caravan Superb XT Black



<b>Code</b>	TH302031 Standard
<b>Code</b>	TH302030 Short (2 bikes)



2 bikes can be increased to 3.  
 Max. bike weight : 30 kg  
 Max. loadable weight: 60 kg  
 Lockable platform : Manual  
 Bicycle holder : Integrated key locks  
 Weight : 9.6 kg

### Thule Caravan Smart



<b>Code</b>	TH307129
-------------	----------



2 bikes  
 Max. bike weight : 30 kg  
 Max. loadable weight: 50 kg  
 Lockable platform : Manual  
 Bike holder : Integrated key locks  
 Weight : 9.6 kg

## BIKE RACKS | THULE<sup>®</sup> SWEDEN

### Thule Sport G2 Compact



<b>Code</b>	TH307341
-------------	----------

2 bikes  
 Max. bike weight : 19 kg  
 Max. loadable weight : 35 kg  
 Lockable platform : Manual  
 Bicycle holder : Optional key locks  
 Weight : 7.2 kg

### Thule Caravan Light



<b>Code</b>	TH306598
-------------	----------

2 bikes  
 Max. bike weight : 20 kg  
 Max. loadable weight : 40 kg  
 Lockable platform : Manual  
 Bicycle holder : Binding  
 Weight : 4.7kg



**Code** TH938000 (13-pin)



**Versatile bike rack for every type of bike**

Thule Velospace XT is a versatile bike carrier for a wide variety of bike types, from e-bikes to toddler bikes. It connects to the drawbar.

**Features**

- Carrying capacity for 2 bicycles
- Weight: 18.6 kg
- Max. loading weight: 60kg
- Max. bike weight: 30kg
- Perfect for e-bikes



**Code** TH933100 (13-pin)



**Code** TH934100 (13-pin)



**Foldable bike rack for all types of bikes**

This user-friendly foldable bike rack is ideal for all types of bikes, including e-bikes and mountain bikes. When not in use, the shelf does not take up any more space than a normal suitcase.

**Features**

- Bicycle carrying capacity can be increased from 2 to 3 bicycles.
- Weight: 17.9 kg / 23.1 kg
- Max. loading weight: 60 kg
- Max. bike weight: 30 kg
- Suitable for e-bikes

can be added / Thule EasyFold XT



**Thule EasyFold XT Loading ramp**

Convenient foldable ramp for easy loading and unloading of your bikes.

**Code** TH933400



**Thule EasyFold XT carrying bag**

Protects you and your vehicle from dirt when transporting and storing the Thule EasyFold XT bike rack.

<b>Code</b>	TH931100 2 bikes
<b>Code</b>	TH934400 3 bikes

**THULE STRAP LOCK**



**Code** TH307389

Strap with a durable steel wire to bind around your bikes and bike rack to secure them during transport - length 3.00 m.

**THULE CABLE LOCK**



**Code** TH538000

Strong, coated cable to secure your bikes - length 1.80 m.

**THULE BIKE FRAME ADAPTER**



**Code** TH982003

Frame adapter for easiest possible fitting of bikes with non-standard frames (e.g. ladies' bikes, downhill bikes).

**THULE BRAKE STRAPS**



**Code** TH306566

By pulling the brakes, sideways movement is prevented and the bikes are more secured on the bike rack during transport - set of 6.

**THULE KNOB WITH LOCK**



<b>Code</b>	TH526000 2 piece
<b>Code</b>	TH527000 4 piece

To replace the knob of bike holders without lock for extra security.

**THULE ACUTIGHT KNOB**



**Code** TH528000

A torque limiter accessory for rear mounted bike carriers with frame holders - replacing the standard knob.

**THULE BIKE COVER**



<b>Code</b>	TH307335 Suitable for 2/3 bikes
<b>Code</b>	TH307336 Suitable for 4 bikes

High quality bike cover to protect your bicycles during transport on a rear-mounted bike rack.

**THULE REAR WARNING SIGN - ITALIAN TYPE**



**Code** TH307619

Officially approved aluminium rear reflecting panel for protruding loads. Suitable for Europe, except for Spain

**THULE BIKE HOLDER 1**



<b>Code</b>	TH306463 Grey
<b>Code</b>	TH302036 Black

Adjustable bike holder with lockable Thule AcuTight torque limiter knob that clicks when optimal torque is reached. For bike racks with tube diameter of 30 mm - length  $\pm$  12 cm.

**THULE BIKE HOLDER 2.5**



<b>Code</b>	THTH307367 Grey
<b>Code</b>	TH302038 Black

Adjustable bike holder with lockable Thule AcuTight torque limiter knob that clicks when optimal torque is reached. For bike racks with tube diameter of 30 mm - length  $\pm$  30 cm.

**THULE BIKE HOLDER 4**



<b>Code</b>	TH306466 Grey
<b>Code</b>	TH302040 Black

Bike holder with lockable Thule AcuTight torque limiter knob to connect bike 3 with bike 4 - length  $\pm$  15 cm.

**THULE BIKE HOLDER 2**



<b>Code</b>	TH306464 Grey
<b>Code</b>	TH302037 Black

Adjustable bike holder with lockable Thule AcuTight torque limiter knob that clicks when optimal torque is reached. For bike racks with tube diameter of 30 mm - length  $\pm$  26 cm.

**THULE BIKE HOLDER 3**



<b>Code</b>	TH306465 Grey
<b>Code</b>	TH302038 Black

Adjustable bike holder with lockable Thule AcuTight torque limiter knob that clicks when optimal torque is reached. For bike racks with tube diameter of 30 mm - length  $\pm$  41 cm.

**THULE E-BIKE RAIL FOR SPORT G2**



<b>Code</b>	TH306945
-------------	----------

To transport one e-bike on a Thule Sport G2 bike rack.

**BIKE RACK - ADAPTERS**



Thule has a large range of bike rack adapters available, developed in cooperation with and approved by the recreational vehicle manufacturers to fit any type of vehicle. Thule advises to let the installation be done by a professional.

## LADDERS

Access your vehicle's roof easily  
and safely.



## LADDER FOR ROOF ACCESS - THULE VAN LADDER 9 STEPS



**Code** TH301404

### Telescopic ladder for easy access to roof accessories

This telescopic ladder offers easy access to roof-mounted accessories.

Easily fixed to vehicle wall with extra stability. Magnetic fixing kit.

- Easy to use wherever you want
- Safe and stable in most terrains
- Ladder can be extended to 2.60 m
- Air pressure system for safe closing
- Compact when not in use

### Thule Van Staircase 9 Steps

#### Features

- Compatible with EN-131
- 9 steps
- Max. weight support : 150 kg
- Dimensions (WxHxD) : 290x750x70mm (closed)  
490x2660x70mm (open)
- Weight ladder : 8.1 kg
- Weight fixation kit : 1.2 kg



#### Package Included

- Thule Van Staircase 9 Steps
- Thule Ladder Fixture Set
- 4 protective patches
- 2 organizer fixing pieces
- Ladder Storage Bag
- Fixation kit storage bag

**THULE LADDER 4 STEPS**



**Code** TH307490

**Features**

- 4 steps
- Backside mounting on a van
- Round tubes

**THULE LADDER 5 STEPS**



**Code** TH307492

**Features**

- 5 steps
- Indoor use
- Round tubes

**THULE LADDER 6 STEPS**



**Code** TH307487

**Features**

- 6 steps
- Backside mounting
- Round tubes

**THULE LADDER DELUXE 6 STEPS**



**Code** TH307496

**Features**

- 6 steps
- Backside mounting
- Oval arms



**THULE LADDER 10 STEPS**



**Code** TH307488

**Features**

- 10 steps
- Backside mounting
- Round tubes
- Foldable

**THULE LADDER DELUXE 11 STEPS**



**Code** TH307497

**Features**

- 11 steps
- Backside mounting
- Oval arms
- Foldable

# ELECTRICAL - ENERGY SYSTEMS

---

SOLAR SYSTEM  
CONTROL PANELS  
BATTERIES  
INVERTERS  
IOT MONITORING  
BATTERY CHARGERS AND CHARGE  
CONTROLLERS  
PORTABLE POWER STATIONS  
CONNECTION CABLES



## RENOGY PROVIDES EVERYTHING YOU NEED FOR AN OFF-GRID SOLAR POWER SYSTEM

Enjoy the fun of Plug and Play solar

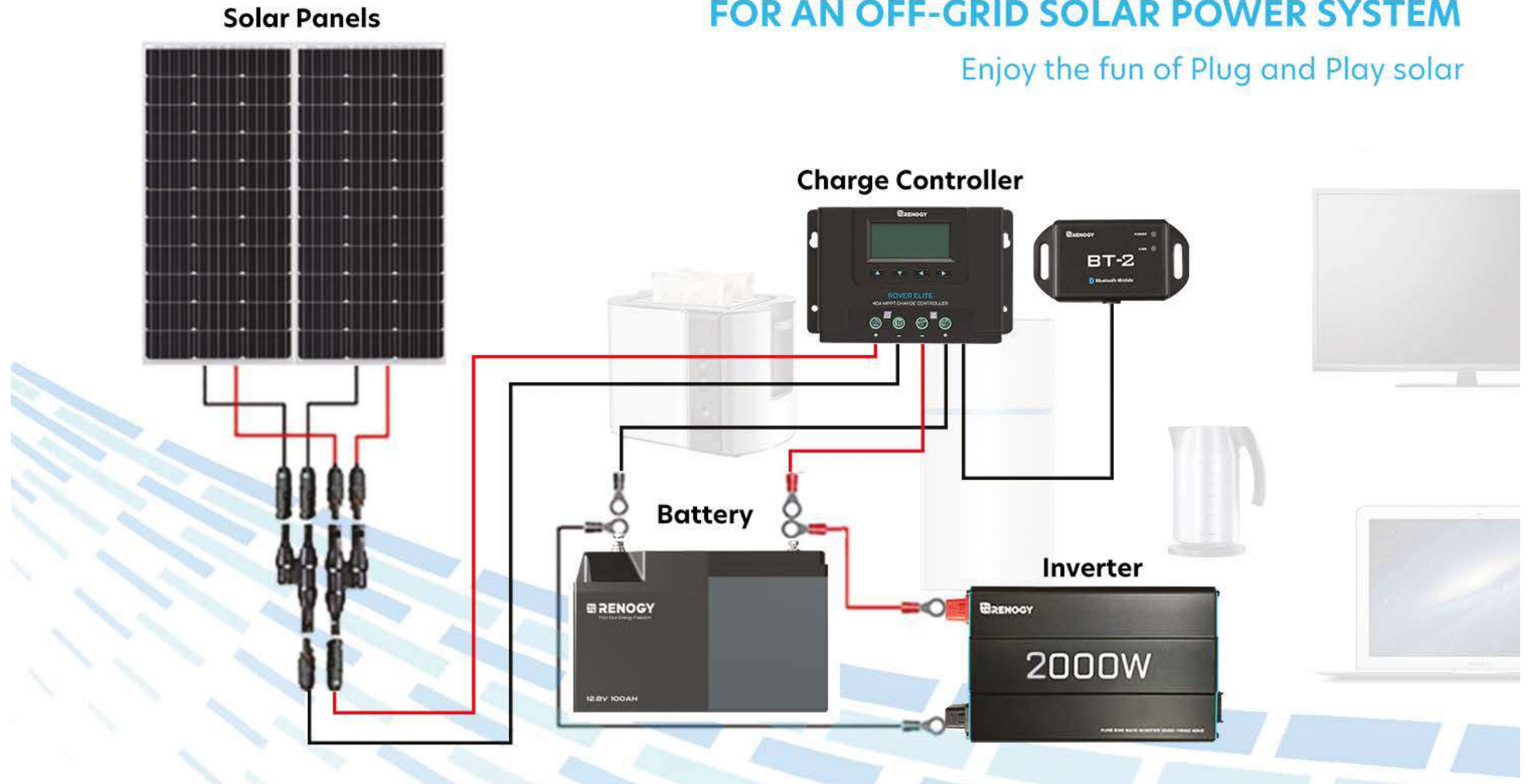

**RENOGY ONE CORE**



**Code** RN-RSHGWSN-WO2W

- Cloud-based energy monitoring worldwide.
- 24/7 energy analysis on multiple devices.
- Built-in RV leveling sensor for stability and comfort.
- Connect smart accessories for home automation.
- Easy installation with horizontal bubble.

Energy efficiency at your fingertips  
Dedicated to off-gridders, Renogy ONE Core helps save money and reduce your carbon footprint by tracking energy generation and consumption.

**Distance is not a problem**  
Remote energy monitoring in various scenarios.

**Need leveling for more comfort?**  
ONE Core assists you in adjusting your RV's position to achieve optimal stability, ensuring a comfortable and safe experience.

**Built-in 6-axis leveling sensor**  
Highly accurate and responsive detection of changes in orientation and rotational movement.

**Real-time RV leveling status**  
Instant and accurate updates about your vehicle's stability on both ONE Core Panel and DC Home App.

**Make it a smart home**  
ONE Core also serves as a smart home hub, allowing you to connect your smart home appliances like door entry alert or climate sensors, enjoy added convenience and security of home automation.

**Peace of mind with 24/7 security**  
Detect unexpected motions occurring in your RV, keep you alert and informed of anything suspicious.

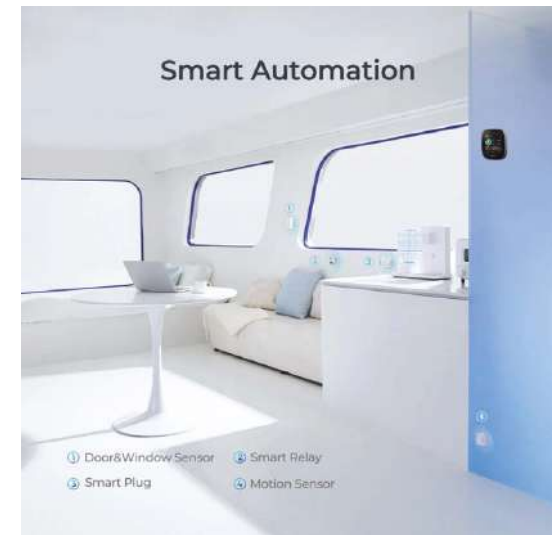

**RENOGY ONE M1**



**Code** RN-RMS-LP4

Introducing Renogy ONE M1, your all-in-one energy monitoring and off-grid smart living center that revolutionizes comfort when you live in your off-grid home or camper van.

Renogy ONE M1 is the heart of your off-grid system with a sleek, flush-mount touchscreen that looks great anywhere. A 4" HD display lets you monitor every compatible Renogy device in your home from one screen. And with the DC Home app you'll have the same system monitoring and energy management wherever you go on your smartphone.

Live off-grid without compromising comfort with Renogy ONE M1. This power monitor gives you control of up to 3 devices at a time through the direct connection with panel relays. For instance, you can create an "Evening" mode that automatically turns on lights or a "Sleep" mode that dims the lights and shuts down the connected appliances.

Renogy ONE M1 delivers peace of mind with enhanced security features for your off-grid home or RV. This off-grid home energy monitor is compatible with our Door and Window Sensors, Motion Sensors and sends instant alerts right to your DC Home app if there's a security breach.

For any questions or comments about this product, submit a case on [renogy.com](https://www.renogy.com).

\*Smart accessories are required for certain features.

**Quick View Energy Control Panel**

Get rid of bulky cables and multiple monitors with the flush-mount Renogy ONE M1. The 4" HD touch screen allows you to monitor and control compatible Renogy devices in your home from a single screen.

**Control All Your Connected Devices**

Renogy ONE M1's panel relays allow you to turn on and off up to 3 DC devices simultaneously via panel switches or the DC Home app. You can even set up different smart scenes to control devices together depending on how you live. For example, you can create for you an "Evening" mode that automatically turns on the lights or a "Sleep" mode that turns off household appliances.

**Remote Energy Monitoring**

The Wi-Fi connection uploads energy data while you're off the grid, so you can monitor your system in real time wherever you are with the DC Home app. You can monitor the status of batteries, charge controllers, and other connected energy devices.

\*You can view historical electricity production data for the last 200 days.

**Energy Monitor**

Visualize Your Solar Power System in One Display

No longer do you need to track data of your energy devices one by one. Now, Renogy ONE M1 delivers all the performance data from connected devices directly to your Smart Panel through Bluetooth, or RS485/RV-C communication cables.



**Remote Monitoring**

Keep Updated with Your Off-Grid Power System at Fingertips

Renogy ONE M1 and the DC Home app combine to deliver energy system information you care about. You can check on real-time energy data, system diagnosis, troubleshooting tips, and other updates from a phone.

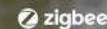
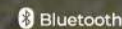

**Home Automation**

Build Off-Grid Homes of the Future

Make your RV or cabin smarter, safer, and more comfortable to live in. Renogy ONE M1 and Smart Sensors allow you to take control of home appliances and initiate smart scenes to streamline your daily routines with a single tap. Best of all, Renogy Smart Sensors actively monitor your home for breaches or hazards to deliver peace of mind while you are away.



**SMART LITHIUM IRON PHOSPHATE BATTERY (100 AH)**



**Code** RN-BT100LFP12S

The Renogy Smart Lithium Iron Phosphate Battery enables auto-balance among parallel connections and provides more flexibility for battery connection. The integrated smart battery management system (BMS), state-of-the-art battery cells, and self-heating function ensure a long cycle life and exceptional discharge performance. If you're searching for a deep cycle battery for caravan, cabin, or marine use, this lightweight, auto-balanced, ultra-safe, long-cycle-life lithium-ion battery is the perfect solution for you!

**Uncompromising Quality**

State-of-the-art battery cells ensure a lifespan of more than 2000 cycles, 100A continuous discharge current, and a wide operating temperature range.

**Easy Upgrades**

Upgrades to lithium seamlessly with the standard BCI group size but a greater energy density, a deeper discharge capability, a higher round-trip efficiency, and a faster charging speed.

**Reliable BMS System**

The state-of-the-art battery management system (BMS) with high-performance dual-processors provides short circuit, over charging and over-temperature protection while maintaining a balanced voltage across all cells.

**Low Temperature Protection Function**

The lithium battery has low temperature charging and discharging protection function. When the temperature is below 0°C, it will stop charging. When the temperature is below -20°C, it will stop discharging.

**Auto-balancing Function**

Easily connect multiple batteries in parallel with the auto-balancing function, improving the average charging efficiency for your batteries in the long term.

**Real-time monitor**

Monitors the battery operation status on mobile devices in real time with the built-in Bluetooth module.

**Technical Specifications**

- Weight : 13 kg
- Dimensions (WxHxD): 330x221x172mm
- Voltage : 12 V
- IP Level : 65



## 12V 100AH PRO SMART LITHIUM IRON PHOSPHATE BATTERY



**Code** RN-RBT12100LFP-BT

### Better Safe than Sorry

According to Lithium-ion Battery Incident Reporting from UL Solutions, over 9000 lithium battery-related incidents have been reported around the world. The rapid growth of lithium batteries also comes with an exponential increase in incidents resulting in injuries and fatalities. It's more critical than ever for us to understand where the great risks exist and take active steps to prevent careless abuse.

### Primary Safety: 60+ EV-Grade BMS Protection

The automotive-grade battery management system built in the 12V 100Ah Pro battery provides over 60 protection and alerts. This brings greater capability and more precise monitoring in all kinds of environments to identify and reduce electrical & thermal hazards.

### Secondary Safety: Active Backup Protection

For the first time, our 12V 100Ah LiFePO4 battery features active backup protection. It helps to cut off the circuit 40x faster than conventional passive protection when a MOSFET switch fails. So it won't compromise your battery packs.

### Double Active Safety System

Designed to safeguard devices, properties, and individuals in an all-around way, the all-new 12V 100Ah Pro Series LiFePO4 Battery combines software and hardware security to avoid incidents actively.

### Brave the Cold for Ice Fishing

For enthusiasts of winter outdoor pursuits, such as ice fishing, a self-heated LiFePO4 battery is a must-have. This 12V 100Ah Pro LiFePO4 battery can automatically heat up with a charging current greater than 4A to ensure safe charging in sub-zero temperatures, providing consistent power to prolong the life of fish finders and other essentials.

### Robust Power Even in Heatwaves

Living in a warmer climate off the grid is made safer than ever with the all-new Pro series lithium battery thanks to the fire-resistant casing (UL94 V-0). It offers outstanding fire resistance to vertical burning, a crucial safety feature to safeguard your power supply against fire hazards and reduce the risks of fire spreading, especially when living in remote areas where emergency response can be delayed.

### Performance You Can Count on

With advanced safety features, Renogy 12V 100Ah Pro takes performance further than ever while ensuring a longer battery lifespan.



### Power to Beat the Cold

 <ul style="list-style-type: none"> <li>✓ Auto-heating below 41°F</li> <li>✓ 20% faster heating</li> <li>✓ No extra installation</li> </ul>	VS	 <ul style="list-style-type: none"> <li>✗ Manual control needed</li> <li>✗ Heat barely reaches the cells</li> <li>✗ Installation required</li> </ul>
--	----	---



### Over-the-Air Update

Simply connect the battery to the DC Home app via Bluetooth, and you can have your battery equipped with upcoming features and improvements to always be at its best.



### UL-Listed Cells

With EV-class battery cells and an all-round comprehensive battery management system, the 12V 100Ah Pro battery can discharge up to 245A for 30 seconds to start the air conditioner and other heavy loads.



### Certified Safety

Having passed through rigorous tests with comprehensive standards, Renogy 12V 100Ah Pro LiFePO4 Battery gives you the confidence and peace of mind to live safely and freely anytime, anywhere.

**1000W 12V PURE SINE WAVE INVERTER**



**Code** RN-INVT-101235

The Renogy 1000W 12V Pure Sine Wave Inverter is perfect for most off-grid systems, for any remote location requiring power. The Renogy 1000W Pure Sine Wave Inverter acts as a DC to AC converter that allows you to power your appliances. Advanced Renogy full sine wave technology will protect and extend the life of your electronic devices. With its quiet and highly inductive loads, your electronic devices will not have strange buzzing sounds when turned on, allowing them to operate softer, cooler and quieter.

**POWERFUL DC-AC**

1000W continuous, 2000W peak ripple at load start, 12V to 220VAC pure sine wave and >90% conversion efficiency, reducing conversion loss.

**SAFE USE**

LED indicators for undervoltage and overvoltage protection, overtemperature protection, overload protection and short circuit indication. Cooling fans and ground fault circuit interrupter (GFCI) protection.

**PROTECTS YOUR ELECTRONIC**

Advanced pure sine wave technology delivers quality AC equivalent to utility power, which will protect and extend the life of your electronic devices. With its quiet and highly inductive loads, your electronic devices won't have strange buzzing noises when turned on, allowing them to run smoother, cooler and quieter.

**Technical Specifications**

Input Volt : 12 V  
 Output Volt : 220 V  
 Peak Power (W) : 2000  
 Weight : 2,72 kg  
 Dimensions (WxHxD) : 327x838x172mm

**2000W 12V PURE SINE WAVE INVERTER**



**Code** RN-INVT-201235

The Renogy 2000W 12V Pure Sine Wave Inverter is perfect for most off-grid systems, for any remote location requiring power. The Renogy 2000W Pure Sine Wave Inverter acts as a DC to AC converter that allows you to power your appliances. Advanced Renogy full sine wave technology will protect and extend the life of your electronic devices. With its quiet and highly inductive loads, your electronic devices will not have strange buzzing sounds when turned on, allowing them to operate softer, cooler and quieter.

**POWERFUL DC-AC**

2000W continuous, 4000W peak ripple at load start, 12V to 220VAC pure sine wave and >90% conversion efficiency, reducing conversion loss.

**SAFE USE**

LED indicators for undervoltage and overvoltage protection, overtemperature protection, overload protection and short circuit indication. Cooling fans and ground fault circuit interrupter (GFCI) protection.

**PROTECTS YOUR ELECTRONIC**

Advanced pure sine wave technology delivers quality AC equivalent to utility power, which will protect and extend the life of your electronic devices. With its quiet and highly inductive loads, your electronic devices won't have strange buzzing noises when turned on, allowing them to run smoother, cooler and quieter.

**Technical Specifications**

Input Volt : 12 V  
 Output Volt : 220 V  
 Peak Power (W) : 4000  
 Weight : 5,30 kg  
 Dimensions (WxHxD) : 452x101x390mm

**3000W 12V PURE SINE WAVE INVERTER**



**Code** RN-INVT-301235

The Renogy 3000W 12V Pure Sine Wave Inverter is perfect for most off-grid systems, for any remote location requiring power. The Renogy 3000W Pure Sine Wave Inverter acts as a DC to AC converter that allows you to power your appliances. Advanced Renogy full sine wave technology will protect and extend the life of your electronic devices. With its quiet and highly inductive loads, your electronic devices will not have strange buzzing sounds when turned on, allowing them to operate softer, cooler and quieter.

**POWERFUL DC-AC**

3000W continuous, 6000W peak ripple at load start, 12V to 220VAC pure sine wave and >90% conversion efficiency, reducing conversion loss.

**SAFE USE**

LED indicators for undervoltage and overvoltage protection, overtemperature protection, overload protection and short circuit indication. Cooling fans and ground fault circuit interrupter (GFCI) protection.

**PROTECTS YOUR ELECTRONIC**

Advanced pure sine wave technology delivers quality AC equivalent to utility power, which will protect and extend the life of your electronic devices. With its quiet and highly inductive loads, your electronic devices won't have strange buzzing noises when turned on, allowing them to run smoother, cooler and quieter.

**Technical Specifications**

Input Volt : 12 V  
 Output Volt : 220 V  
 Peak Power (W) : 6000  
 Weight : 5,66 kg  
 Dimensions (WxHxD) : 480x101x228mm



## BT-2 BLUETOOTH MODULE



**Code** RN-RCM-BT2

The Renogy BT-2 is the new generation Bluetooth module for select Renogy solar charge controllers, DC-DC battery chargers, smart lithium batteries, and inverters. Powered by its RJ45 communication port, the BT-2 provides wireless monitoring of the system data and allows users to change parameters through the Renogy DC Home smartphone App. The Renogy DC Home App can help make your off-grid power system smarter by giving you access to configure, monitor, update, and diagnose your Renogy products from the convenience of your smart phone or tablet.

### Precise Control Over Your Devices

with all Renogy RS485 communication port products includes the Rover Elite MPPT Solar Charge Controller, Smart Lithium Batteries, Pure Sine Wave Inverter with Power Saving Mode, and Dual DC-DC MPPT Battery Charger.

### Real-time Insight

Get real-time and historical data via Bluetooth Module and Renogy DC Home App. Bluetooth 4.2 and BLE technology provides fast and uninterrupted communication.

### User-friendly

Easily connect the Bluetooth Module to the RS485 communication port, and follow the App instructions. The Bluetooth Module is powered by solar energy, and the ultra-low-power dedicated chip will allow signal range up to 82ft.

**CONTROL YOUR RENOGY DEVICES VIA BT-2 BLUETOOTH MODULE**

Make your off-grid power system smarter by simply configuring, monitor, update and diagnose your Renogy products.

Download on the App Store | Download for Android

**Solar Charging Data**    **Energy Storage**    **Inverters**

**Precise Control Over Your Devices**

**82ft(25m)**

### REGO 12V MPPT SOLAR CHARGE CONTROLLER (60A)

**Code** RN-RCC60REGO-US

The REGO 12V 60A MPPT Solar Charge Controller focuses on the simplified installation and comprehensive protections for the whole solar system. Plug-and-play hookups for rapid connection, save on installation time than traditional controllers. The integrated high BPU (Battery Protect Unit) technology achieves the highest protection against battery cell damage and battery failure, safeguarding the entire system. With the most efficient MPPT technology with high tracking efficiency of up to 99%, maximum the power generated by solar panels to provide more power for your system. The compact and robust nature of the controller not only has a sense of technology and fashion but also saves on installation space relative to the competition. Add the REGO 12V 60A MPPT Solar Charge Controller, one of the most efficient and reliable controllers on the market yet to your system.

#### Comprehensive Protections for Whole System

The REGO charge controller with multiple protections on both solar input and battery output terminals. The integrated high BPU (Battery Protect Unit) technology achieves the highest protection against battery cell damage and battery failure, safeguarding the entire system.

#### Easy Installation and Operation

REGO charge controller use Anderson terminals with a specially designed Anderson to MC4 adaptor cable for a simple and easy way to connect the controller to your solar panels, cutting installation time by 60%! REGO's simple design eliminates tedious data settings and lets you switch between batteries by just turning a knob.

#### Ultra-High Tracking Efficiency

Innovative MPPT technology of the REGO provides high tracking efficiency of up to 99% and peak conversion efficiency of 98%, which is the best charging solution even in cloudy environments where the max power point of the solar panels will fluctuate all day. Adopts a four-stage charging (Bulk, Boost, Float, EQU), ensuring high charging efficiency and optimizing the battery status for a longer lifespan.

#### Compatible with Multiple Batteries Types

The REGO charge controller is compatible with multiple types of batteries: AGM, SLD, Flooded, Gel, and Lithium, able to be perfectly and easily added to your solar system, providing a powerful solution for different occasions.

#### Puts Monitoring and Control in Your Hands

Built-in Bluetooth allows you to monitor the REGO charge controller on your smartphone with the Renogy DC Home App. With the app, you can customize multiple battery data such as the boost voltage, float voltage, and duration data.

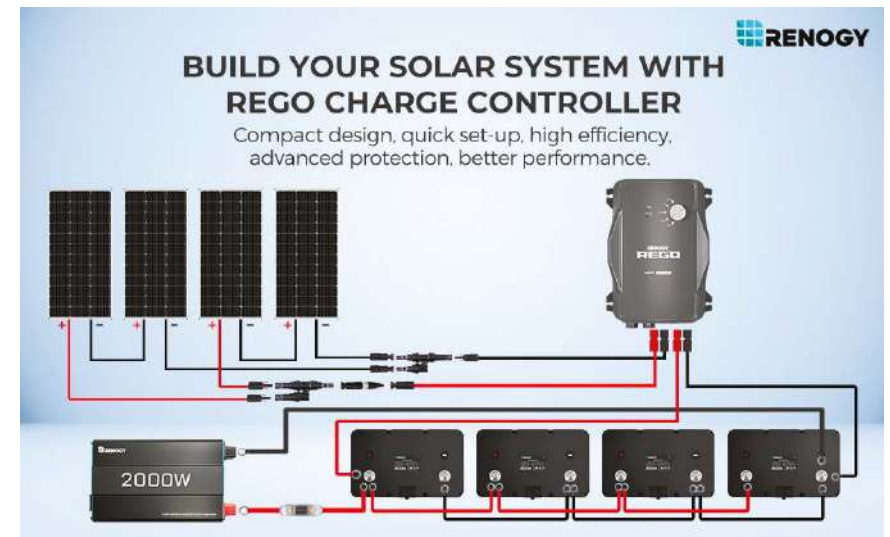

## ULTRA FAST MAXIMUM POWER POINT TRACKING

Up to **99%** Tracking Efficiency



## EASY PLUG&PLAY CONNECTION

No more complex wiring required with standard Anderson connections.

Installs in Less than **1/2** the Time

High capacity 6AWG Anderson to MC4 Cable (Connect to Solar Panel)

6AWG Anderson to 3/8 Ring Adapter Cable (Connect to Non-RENOGY House Battery) (Sold Separately)



## MONITOR AND OPTIMIZE CHARGING FROM YOUR PHONE

Built in bluetooth connectivity allows you to monitor and manage the controller with your smart phone using the Renogy DC Home App



## NEXT-LEVEL PROTECTION FOR THE WHOLE SYSTEM

**High-temperature Protection**  
RENOGY's smart technology eliminates risk of battery and charge controller damage from high temperatures.

**Integrated Battery Protection Unit (BPU)**  
The BPU provides advanced protection against short circuit and device damage.



**Solar Terminal Protection**

- Overvoltage Protection
- Short Circuit Protection
- Night Back-flow Protection

**Battery Terminal Protection**

- Overcharge Protection
- Overdischarge Protection
- Reverse Polarity Protection

## SIMPLE BATTERY TYPE SETUP

Reliable and easy-to-use selector, no more complicated settings or wiring required

Set up and optimized performance are easy with pre-programmed charge settings. Simply select your battery type by turning the knob. To customize settings for your application using the **DC Home APP**, select **USER**.



**USER Mode**   **Lithium Battery**   **Flooded Battery**   **Gel Battery**   **AGM Battery**



**Overland**   **RV**   **Marine**   **Van**

## DC TO DC ON-BOARD BATTERY CHARGER



<b>Code</b>	RN-DCC1212-20 20A
<b>Code</b>	RN-DCC1212-40 40A

The DC-DC Battery Chargers are the most effective way to charge your house batteries from the starter battery. Compatible with a multitude of alternator types, the DC-DC battery charger offers correct charging for AGM, Flooded, Gel, and even Lithium deep cycle batteries! Featuring a 3-stage battery charger and multiple electronic protections, users can feel confident that their batteries are being charged optimally and automatically. For additional safety, it isolates the input from the output preventing incorrect voltage transmission. Easily install the compact yet sturdy DC-DC battery charger on RV's, commercial vehicles, boats, yachts, and many more applications!

**Compatible Multiple Battery Types** Compatible with a multitude of alternator types, the DC-DC battery charger offers correct charging for AGM, Flooded, Gel, and Lithium batteries.

**Smart 3-stage Charging** The DC-DC battery charger will charge your house batteries from the starter battery by 3-stage charging (Bulk, Boost, and Float), to make sure it optimally and automatically charge to 100%.

**Various Protections For Ultra Safety** Offers Over-voltage Protection, Over-temperature Protection, and Reverse Polarity Protection to ensure the operation safety. It also isolates the input and output to prevent voltage transmission errors and interfere with house battery charging.

**Protect Your Starter Battery** The DC-DC battery charger is capable of identifying whether the generator is started, to prevent over-discharge of the starting battery and protect the generator. (18-16AWG copper cable recommended. Please note the D+ Ignition Cable is not included.

## DC-DC ON-BOARD BATTERY CHARGER WITH MPPT



<b>Code</b>	RN-BC30D1S 30A
<b>Code</b>	RN-BC50D1S 50A

Renogy's DC to DC MPPT on-board Battery Charger is designed to give you options! This multi-stage, multi-input battery charger can charge a service battery from a starting battery linked to an alternator or by utilizing solar panels connected directly to the unit. While your vehicle's alternator prioritizes your starting battery, this unit will allow your solar system to charge your service battery first! It's the smart way to keep yourself fully charged and off-grid longer! And with multi-stage charging and multi-chemistry functionality, Renogy's DC to DC MPPT Charger has you covered whether you're using Flooded, Gel, AGM, or Lithium batteries. With RJ45 communication port featured, you can unlock monitoring features exclusively using the BT-2 Bluetooth Module and Renogy DC Home App, control and monitor the device remotely through your phone in real time.

**Sturdy Design for UltraSafe:** Comes with sturdy compact design, this Renogy DC-DC On-Board Battery Charger with MPPT can be safely and easily connected to any 12-volt system and allows safe operation in any position or portable devices without the worry of incorrect connections or sparks.

**Built-in MPPT Maximizing Solar Power:** With Built-in Maximum Power Point Tracking (MPPT) technology, this battery charger with MPPT maximizes the solar power when charging from solar panels, and ensures that the loads receive maximum current to be used.

## ROVER ELITE MPPT SOLAR CHARGE CONTROLLER



<b>Code</b>	RN-CC20RVRE 20A
<b>Code</b>	RN-CC40RVRE 40A

The Rover Elite series of MPPT charge controllers give you the most efficient charging for countless 12V or 24V off-grid solar applications. Compatible with an assortment of batteries, including Lithium, the Rover Elite MPPT utilizes powerfully smart tracking technology to maximize solar charging energy to your battery. Additionally, the Rover Elite MPPT is equipped with multiple battery, controller, and solar protections giving you peace of mind and an optimized system you can trust.

Please Note: The Rover Elite is not compatible with the Renogy BT-1, only compatible with BT-2 Bluetooth module.

- 12V /24V Automatic System Recognition.
- Backlit LCD displays system information and identifying error codes.
- Advanced MPPT Technology with up to 99% high tracking efficiency, 96% conversion efficiency and Lithium-reawakening feature.
- 4 Deep Cycle Battery Pre-Sets: Gel, Flooded, Lithium-Iron Phosphate (12.8V), and Sealed/AGM.
- Multiple Electronic Protection Features, including over-charging, over-discharging, reverse polarity, over-load and over-temperature.

## ROVER LI MPPT SOLAR CHARGE CONTROLLER (20A)



**Code** RN-RNG-CTRL-RVR20

Our panels are compatible with mainstream trackers. By leveraging optimal angles and open spaces, you can maximize solar energy generation and experience the peace of mind that comes with being self-sufficient.

Rest assured, you won't waste a single watt. Thanks to the high efficiency of bifacial panels, any excess energy generated by your solar panels can be stored in batteries for future use or sold back to the main power grid. Installing a solar roof is a wise financial decision that enhances the value of your home.

### Certified Protections

The Renogy Rover 20A Solar Charge Controller features 8 electronic protections to actively monitor changes of voltage, current, and load for efficient and safe battery charging.

### Bring Dead Batteries to Life

Activates dead batteries with small current to get it out of protection mode triggered by the battery management system (BMS).

### Stay Cool, Stay Empowered

Made of robust die-cast aluminum, the heat sink that comes with the Rover 20A Solar Charge Controller allows the heat flow away through tubes to ensure maximum charging efficiency and safety of critical components.

### Charging with Precision

The included external temperature sensor helps Rover 20A Solar Charge Controller track the battery's temperature all year round, avoiding under-charging in cold climates down to -40°F, and overcharging in blazing weather up to 149°F.

### Ready-to-Install

Package includes a Rover 20A Solar Charge Controller, a temperature sensor, several mounting brackets, and a user manual.

### Versatile Load Control

Rover 20A Charge Controller features Auto-On/Off Mode, Timer Mode, Manual Mode, Test Mode, and Always-On Mode, further maximizing your system flexibility.



## VOYAGER PWM WATERPROOF SOLAR CHARGE CONTROLLER (20A)



**Code** RN-CC20VOYP

The Voyager 20A is a class leading 20-amp charge controller with an IP67 rating. It is perfect for outdoor use, and can withstand water spray, rain, and condensation. Equipped with advanced PWM technology, it supports both 12V and 24V off-grid applications, and is compatible with 4 different battery types, including Lithium Iron Phosphate. The Voyager 20A also ensures your system's longevity with solar panel, battery, and controller protections.

**Note:** Please set the voltage manually to charge lithium batteries.

### 4-STAGE PWM Technology

The Voyager controller is equipped with advanced smart PWM technology with high charging efficiency. It provides 4-stage charging (Bulk, Absorption, Float and Equalization) in order to protect the battery.

### IP67 Rated Waterproof

With an IP67 rated waterproof design, the Voyager controller is suitable for outdoor use and will remain fully operational when exposed to water spray, rain, or condensation.

### Multiple Protections

The Voyager controller has multiple intelligent protections against reverse polarity, over charge, short-circuit, reverse current, overload, and over discharge, keeping your battery fully protected.

### Support Multiple Battery Types

The Voyager controller can automatically sense 12V or 24V system voltage when paired with a Gel, AGM, or Flooded batteries. It also comes with a Lithium activation feature.

### Backlit LCD displaying system

The Voyager comes with an LCD display showing accurate and timely information including charging current, generated energy, temperature, battery voltage, and error codes that allows users to monitor and control charging.

## 500A BATTERY MONITOR



**Code** RN-BM500

The Renogy Battery Monitor is designed to monitor performance for most kinds of batteries. Its high-precision measurements will eliminate the guesswork from battery usage and improve your battery bank's overall performance and longevity!

It is a universal battery monitor that you can use with voltage ranging from 10V to 120V and up to 500A.

- Compatible with various types of battery: Lead Acid, Lithium Iron Phosphate, Lithium-ion, Nickel-metal hybrid
- High precision current detection
- High and Low Voltage Programmable Alarm - Backlight and voltage value will flash simultaneously
- Data Storage - Designed to automatically store the last testing data when system shuts off
- Displays multiple electronic parameters (Voltage, Current, Consumed Power and Battery Capacity)
- Universal Battery Monitor- Voltage range 10V-120V and up to 500A
- Accurate Battery SOC%
- Large backlit LCD Display

### Technical Specifications

Weight: 75 gr

Dimensions (WxHxD): 99x61x18mm

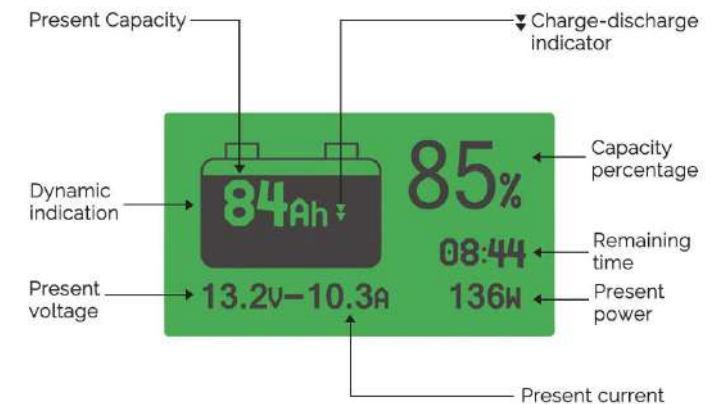

## OPEN BOX RENOGY 300 POWER STATION



**Code** RN-300PHXE

With a capacity of 23400mAh, the Renogy PHOENIX 300 Power Station is one of the smallest and lightest rechargeable AC portable generators in its class. Thanks to its connection feature with the solar panel, it can be charged with solar energy.

### POWERFUL PORTABLE POWER STATION

Powering your off-grid adventure, the Renogy Phoenix 23400 mAh powerful portable generator delivers stable 200W power to charge everything from laptops, tablets and smartphones to handheld video game consoles, drones, cameras, mini refrigerators, lights, speakers, TVs, CPAP machines and much more

### RATE OF REVOLUTION

Equipped with a 60W fast charging Type-C port and a 18W USB-A port for 60% faster charging time, the Phoenix 300 portable generator will juice up smartphones, laptops, and your MacBook Air at top speed in less than 2 hours.

### DURABLE AND SAFE

With a UL-listed lithium-ion battery at its core, the Phoenix 300 can achieve over 1000 life cycles and utilize full sine wave to deliver clean, quiet and stable AC power. Additionally, Renogy advanced BMS provides short circuit protection, voltage control, temperature control and more advanced safety operations.

### 3 CHARGING METHODS

Phoenix can be charged via the DC 12-25V input port, wall sockets, and a car port via the fast-charging 60W PD Port. Alternatively, connect it directly to a solar panel and charge using direct sunlight. You can also combine input charging methods to maximize charging time and be fully charged in 3.5 hours.

### Technical Specifications

Capacity : 14.4V / 23400mAh / 337Wh  
 Type : Lithium-ion  
 Weight : 2.9 kg  
 Dimensions (WxHxD) : 181x155x143mm

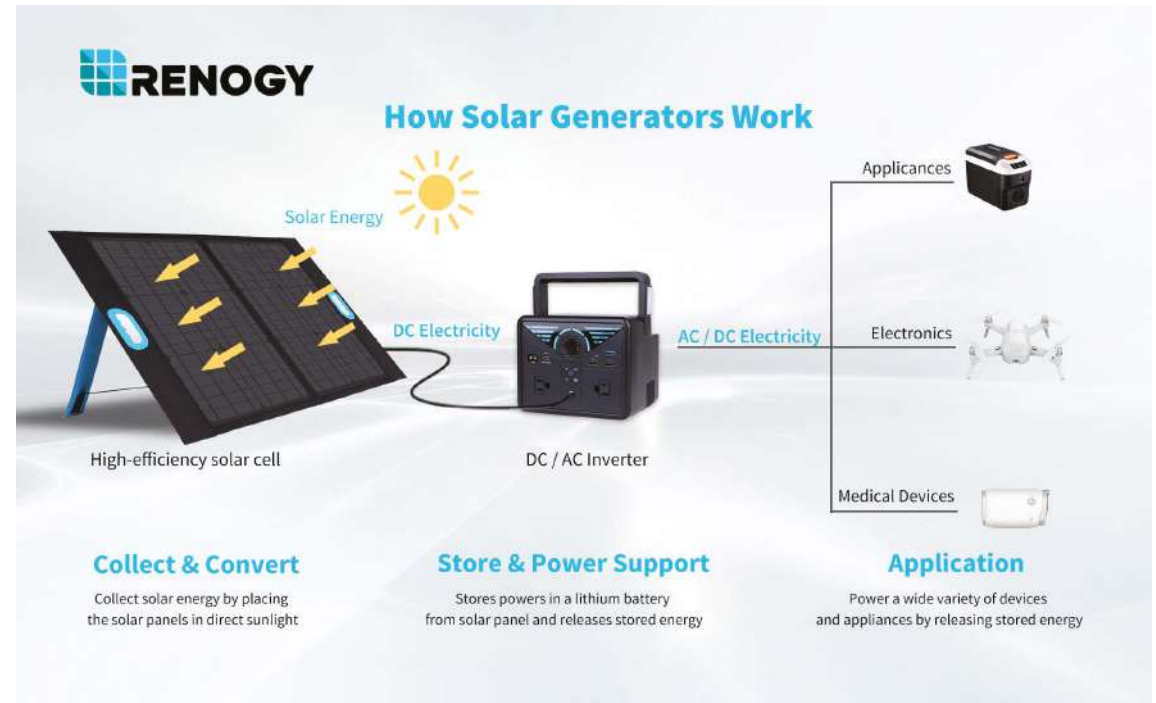

**RENOGY PORTABLE POWER STATION 200**



**Code** RN-RPS2220AA



Take power wherever you go. Renogy Power Station 200 is one of the lightest portable power stations with only 5.3 pounds and a capacity of 222Wh. Renogy Power Station 200 can be charged to 80% in 1.5 hours when AC and USB-C are charged simultaneously at maximum power. It provides 4 recharging options: AC, USB-C, solar, and car. The Renogy Power Station 200 can power 6 devices simultaneously and charge devices while recharging itself. It's ideal for camping, road trips, photography, remote work, and outdoor activities.

**Multi Intelligent BMS Protection**

Renogy 200 portable power station camping has a built-in advanced battery management system, that protects you and the devices you with reverse polarity protection, high/low temperature protection, short circuit protection, undervoltage protection, overvoltage protection, overcurrent protection.

**Quick Charging & Versatile Outputs**

The solar power generator Renogy 200 solar generator can power up to 6 devices simultaneously with multiple outlet options, including 2 pure sine wave AC outlets, 2 USB-A fast charging ports, 1 USB-C port, and 1 CIG port. The USB-C port can charge your devices at full speed without the bulky adapters, including phones, laptops, and handheld game consoles. Note that the total rated wattage of the AC outlets should be under 200W (surge 400W).

**Fast Recharging**

Renogy 200 solar generator can be charged to 80% in 1.5 hours when AC and USB-C are charged simultaneously at maximum power. This portable generator for camping provides 4 recharging methods: AC, USB-C, solar, and car. The diverse charging options suit different usage scenarios, such as home, car, and outdoor.

**200W Pure Sine Wave AC Outlet**

The built-in pure sine wave inverter can provide up to 200W clean and stable electricity with the pure sine wave, equivalent to grid power which will protect your sensitive equipment such as CPAP, laptops, tablet PC, camera, drone and etc.

**Light & Compact**

Take the portable power generator wherever you go. PHX200 is one of the lightest solar power station with only 5.3 pounds and a capacity of 222Wh. You will receive 1\* PHX200 Portable Power Station; 1\* AC Adapter(19V=3.42A); 1\* AC Power Cable(18AWG); 1\* Car Charge Cable(16AWG); 1\* User Manual: 1 year warranty.

**Intelligent & Convenient**

Quickly check your charging status with an informative LCD display, including battery level, input and output power, and estimated recharging time. PHX200, the portable power generator will automatically shut down when not charging for a certain period to save power. The 200w power station can also be set to disable and enable CIG Port and AC Outlets by the simple push of buttons, to meet your needs.







**DEFA Connection Set 460785**

MiniPlug power cable 1.5 m : DF460915  
 MiniPlug connection cable 2.5 m : DF460920  
 MiniPlug power cable - Bracket : DF418801

**DEFA Connection Set 460787**

MiniPlug power cable 1.5 m : DF460915  
 MiniPlug connection cable 5.0 m : DF460921  
 MiniPlug product cable - Bracket : DF418801



**DEFA MiniPlug Connection Cable 1.5 mm<sup>2</sup>**

Voltage (VAC) : 220  
 Current (A) : 16  
 Length/Weight : 2.5m/0.420kg - 5m/0.695kg  
 10m/1.18kg - 15m/1.70kg

Product Code (2.5m) : DF460920  
 Product Code (2.5m) : DF460933  
 Product Code (5m) : DF460921  
 Product Code (10m) : DF460924  
 Product Code (15m) : DF460936



**DEFA MiniPlug Connection Cable 2.5 mm<sup>2</sup>**

DEFA Electrical cables can be applied to vehicles with special equipment such as ambulances and fire trucks. Although the cable is offered with a 2.5 mm<sup>2</sup> cross-section, the maximum current is 16A.

Voltage (VAC) : 220  
 Current (A) : 16  
 Weight : 2.5m/0.530kg - 5m/0.915kg  
 10m/1.50kg

Product Code (2.5 m) : DF460960  
 Product Code (5.0 m) : DF460961  
 Product Code (10.0 m) : DF460962



**DEFA MiniPlug Power cable**

DEFA MiniPlug Supply cable is designed to be adaptable to all new vehicles. It is functional and easy to mount flush-mounted (built-in) with a bracket. During the development of the DEFA MiniPlug, correct design, safety, optimum installation and use were taken into account.

Voltage (VAC) : 220  
 Current (A) : 16

Product Code (0.6m) : DF460902  
 Product Code (1.9m) : DF460901  
 Product Code (1.5m) : DF460915  
 Product Code (2.0m) : DF460939



**DEFA PlugIn Extension Cable**

The elements in the DEFA PowerSystem are easily connected to each other with DEFA's PlugIn extension cables. This system is designed to ensure a safe, tight connection and prevent incorrect connection.

Voltage (VAC) : 220  
 Current (A) : 16  
 IP Level : 44

**Product Code Extension cable**

DF460802	0.5m
DF460803	1.0m
DF460843	1.5m
DF460804	2.0m
DF460844	3.0m
DF460846	4.0m
DF460809	5.0m
DF460847	8.0m
DF460851	10m
DF460850	12.0m

## SOCKET INLET AND COVERS

---

Recreational vehicle inlets stand out by way of their elegant design and their pictograms for the easy differentiation of their respective function.



## ELECTRICAL INPUT



<b>Code</b>	ABL3164001 White
<b>Code</b>	ABL3164000 Black
<b>Code</b>	ABL3164006 Grey

Power inlets enable a power supply to the campervan or caravan, and are therefore part of an RV's basic equipment.

### Safety

High, 850° C fire protection class, self-extinguishing plastic.

### User-Friendliness

CEE connector with self-opening safety latch.

### Large wiring space

for a comfortable and quick wiring up process.

### Cap Colors



White   Grey   Black

## WATER FILLER NECK



<b>Code</b>	ABL3163001 White
<b>Code</b>	ABL3163002 Black
<b>Code</b>	ABL3163003 Grey

The RV's water tank can be filled comfortably via the water filler neck.

### High-Quality materials

Licensed according to KTW and W270.

### Suitable for hsc and zadi locks

### Cap Colors



White   Grey   Black

## TOWN WATER SOCKET INLET



<b>Code</b>	ABL3166001 White
<b>Code</b>	ABL3166002 Black
<b>Code</b>	ABL3166003 Grey

A town water socket inlet allows intake to the vehicle's tank from a public water supply. This enables an uninterrupted supply beyond the capacity of the vehicle's built-in water tank.

### Suitable for

Male coupling for half-inch water couplings.

### With integrated pressure regulator

reduces the pressure of the public water supply.

### High performance

Inlet pressure up to 10 bar, flow pressure 1.0 bar, idle pressure 1.5 bar. Output 7 l/min.

### Cap Colors



White   Grey   Black

## MULTIFUNCTIONAL ELECTRICAL SOCKET



<b>Code</b>	ABL3165101 White
<b>Code</b>	ABL3165100 Black
<b>Code</b>	ABL3165102 Grey

Multi-purpose sockets cover a multitude of application scenarios and allow for connecting a range of devices. For example, a TV can be connected in the annex of a campervan.

### Several standards available

SCHUKO, French/Belgian, British Standard, USB etc.

### Various applications

Equipped with 12 V DC socket outlet and two SAT sockets.

### Cap Colors



White   Grey   Black

# SOCKET INLET AND COVERS

## WATER SOCKET OUTLET BASIC

**ABL**



**Code** ABL3168001

Water socket outlet for external water connection. A water socket outlet enables connecting a hose or other water consuming device.

## BLANK SOCKET FLAT WITH CLOSED REAR

**ABL**



**Code** ABL3167004

Blank socket with closed rear wall for the installation of individualised components.

### Universally applicable

Depth: 24.5 mm, easy to replace cover lid.

## FILLER NECK FOR FRESH WATER OR DIESEL

**STS**  
Oberholz



**Code** ST9635-W40100-814

Same key-opening feature as HARTAL doors and Thetford service doors!

### Technical Specifications

Ø 35 mm, Ø 40 mm  
L: 100 mm short, L: 145 mm long  
with or without ventilation  
suitable for drinking water (comply with the new drinking water regulations)

## GAS SOCKET OUTLET BBQ POINT

**truma**



**Code** TU23291-03  
Black



**Code** TU23291-01  
White

### Technical Specifications

Gas pressure : 30/50 mbar  
Color : White / Black

- Enjoy outdoor barbecuing with BBQ point.
- Very easy one-handed operation.
- Operation with a working pressure of 30 or 50 mbar.
- Waterproof.
- Connect outdoor gas devices to the gas distribution valve.

**Code** ABL3168021

Water socket outlet for external water connection. A water socket outlet enables connecting a hose or other water consuming device.



## SECURITY SYSTEMS

---

Alarm and lock systems developed to provide security to users in all situations such as theft, fire, robbery, extortion, etc.



**THULE SECURITY HANDRAIL**



**Thule Security Handrail**

This handrail has a unique double locking design for extra safety. In the open position it offers a sturdy grasp handle to help getting in and out the vehicle and in its locked position it folds across the door giving added visible security.

PAKET	
<b>Code</b>	TH308892 1 piece
<b>Code</b>	TH308893 Thule security handrail door frame kit



**Thule Security Handrail - Short Version**

This sturdy and easy-to-fit handrail is ideal for a motorhome or caravan with a lower entry door. In the open position it offers a sturdy grasp handle to help getting in and out the vehicle and in its locked position it folds across the door giving added visible security.

PAKET	
<b>Code</b>	TH307387 1 piece
<b>Code</b>	TH308893 Thule security handrail door frame kit



## THULE UNIVERSAL LOCK



PACK (WHITE)	
<b>Code</b>	TH301406 1 piece
<b>Code</b>	TH301419 2 piece
<b>Code</b>	TH301407 3 piece

PACK (BLACK)	
<b>Code</b>	TH301408 1 piece
<b>Code</b>	TH301409 2 piece

### Features

- Large overlap with door for high security
- Strong rotating lock system
- The door frame bracket only requires 3 mm gap between door and frame
- Fits left or right opening doors
- Available in the colors white and black

### 3 different mounting options with the same lock

This high security lock fits all: motorhome, caravan. Possible to mount the same lock in three different ways. The surface-mounted installation is perfect for sliding doors, cabin doors. The wall-mounted and the door frame-mounted installations are perfect for the entrance door, the garage door or the hatches of a motorhome or caravan.



## THULE INSIDE-OUT LOCK G2



PACK	
<b>Code</b>	TH307339 1 piece



### Secures the entrance door both from the inside and outside

High security lock for motorhome and caravan. This lock is mounted through the wall of your vehicle and secures the entrance door from the inside and outside. It's lockable from both sides but for your safety it can always be opened from the inside without a key.

### Features

- Limited space required for installation
- Large overlap with door for high security
- Can be installed horizontally or vertically
- Max. wall thickness: 45 mm





**THULE DOOR LOCK**



PACK	
<b>Code</b>	TH308888 1 piece
<b>Code</b>	TH308890 3 piece



This quality door lock is easy to use: just slide it sideways to lock and secure your doors. Mounted through the wall with a mounting plate, a sealing cover and bolts.

**THULE DOOR FRAME LOCK**



PACK	
<b>Code</b>	TH308889 1 piece
<b>Code</b>	TH308891 3 piece



This variant of the Thule Door Lock enables installation when there is no space inside the vehicle to fit the mounting plate. Instead of through the wall, it is screwed into the door frame.

**THULE CAB LOCK**



PACK	
<b>Code</b>	TH309830 2 piece Ducato, Jumper, Boxer
<b>Code</b>	TH309831 2 parça Sprinter, Master, Crafter, Movano



This lock secures your cabin door from the inside with a key. It offers a soft touch cover and matches the colour of your interior.

**THULE VAN LOCK**



PACK	
<b>Code</b>	TH309832 1 piece
<b>Code</b>	TH309833 2 piece



Thule Van lock helps you protect sliding side doors. Smart and attractive, it fits all van models and matches the color of your van bumper.

## FURNITURE AND LOCKING SYSTEMS

---

PUSH-PULL LOCKS  
FURNITURE HANDLES  
SHELF HOLDERS  
DOOR LOCKS  
HOOKS  
ACCESSORIES



**PUSH LOCK - V1445**



**Code** BCV1445

**Technical Specifications**

Material : Zamak  
Color : Chrome  
Weight : 88 gr

**PUSH LOCK - AS238ZA**



**Code** BCAS238ZA

**Technical Specifications**

Material : Zamak  
Color : Chrome  
Weight : 88 gr (Excluding lock system)

**PUSH LOCK - AS238**



**Code** BCAS238

**Technical Specifications**

Material : ABS  
Color : Chrome  
Weight : 6 gr (Excluding lock system)

**Note:** With anti-rotation pin.

**PUSH LOCK - AS1833**



**Code** BCBT1105

**Technical Specifications**

Material : Zamak  
Color : Chrome  
Weight : 46 gr (Excluding lock system)

**PUSH LOCK - AS238R**

**NEW**



**Code** BCAS238R

**Technical Specifications**

Material : ABS (Also available as Zamak)  
Color : Chrome  
Weight : 6 gr (Excluding lock system)

**PUSH LOCK - AS238R**

**NEW**



**Code** BCSD3401TITGTSE

**Technical Specifications**

Material : ABS  
Color : Matte titanium  
Weight : 6 gr (Excluding lock system)

**PUSH LOCK - AS238R**

**NEW**



**Code** BCSD3401BMGTSE

**Technical Specifications**

Material : ABS  
Color : Matte black  
Weight : 6 gr (Excluding lock system)

**PUSH LOCK - AS1833**

**NEW**



**Code** BCBKAS1833.15NO

**Technical Specifications**

Material : ABS  
Color : Matte black

**HIDDEN PUSH LOCK - V510**



**Code** BCV510

**Technical Specifications**

Material : Zamak  
Color : Nickel plating  
Weight : 50 gr

**PUSH LOCK - BT1103**



**Code** BCBT1103

**Technical Specifications**

Material : Zamak  
Color : Chrome  
Weight : 60 gr

**PUSH LOCK - BT1103**



**Code** BCBT1103OP

**Technical Specifications**

Material : Zamak  
Color : Mat Gold  
Weight : 60 gr

**PUSH LOCK - BT1103**



**Code** BCBT1103NESER

**Technical Specifications**

Material : Zamak  
Color : Black  
Weight : 60 gr

**PUSH LOCK - BT1300**



**Code** BCBT1300CL

**Technical Specifications**

Material : Zamak ve Abs  
Color : Shiny gray  
Weight : 40 gr

**PUSH LOCK - BT11292**



**Code** BCBT11292

**Technical Specifications**

Material : Zamak  
Color : Chrome  
Weight : 69 gr

**PUSH LOCK - BT11293**



**Code** BCBT11293

**Technical Specifications**

Material : Zamak  
Color : Chrome  
Weight : 126 gr

**PUSH LOCK - BT11292**



**Code** BCBT1292BC

**Technical Specifications**

Material : Zamak  
Color : Matte Rose Gold  
Weight : Approx 126 gr

**PUSH BUTTON HANDLE - V1614**



**Code** BCV1614

**Technical Specifications**

Material : Zamak  
Color : Shiny chrome  
Weight : 156 gr

**PUSH BUTTON HANDLE - V1614**

**NEW**



**Code** BCAS1614NEK

**Technical Specifications**

Material : Zamak  
Color : Matte black  
Weight : 156 gr

**PULL OPEN HANDLE - AS235**



**Code** BCAS235

**Technical Specifications**

Material : Abs  
Color : Polished Chrome  
Weight : 20 gr

**HANDLE - V1099**

**NEW**



**Code** BCTCOV1099NE

**Technical Specifications**

Material : Zamak  
Color : Matte black  
Weight : 500 gr.

**HANDLE - V2301**

**NEW**



**Code** BCV2301

**Technical Specifications**

Material : Zamak  
Color : Black  
Weight : 415 gr.  
Feature : Also available with leather covering

**HANDLE - V2301**

**NEW**



**Code** BCTCOV2301BC

**Technical Specifications**

Material : Zamak  
Color : Matte rose gold  
Weight : 415 gr.

**HANDLE FOR DOOR - V1282**



**Code** BCV1282

**Technical Specifications**

Material : Zamak  
Color : Silver  
Weight : 130 gr

**BLACK HANDLE FOR DOOR**

**NEW**



**Code** BCM4.0001.00N010062

**Technical Specifications**

Material : Zamak  
Color : Matte black  
Weight : 130 gr



**HANDLE FOR DOOR - V1786**



**Code** BCSDDB3432CL80SER

**Technical Specifications**

Material : Zamak  
Color : Chrome  
Weight : 130 gr

**HANDLE FOR DOOR - V1786**



**Code** BCSDDB342OR.80

**Technical Specifications**

Material : Zamak  
Color : Matte gold  
Weight : 130 gr

**HANDLE FOR DOOR - V1559**



**Code** BCSDDB3353BC80

**Technical Specifications**

Material : Zamak  
Color : Matte rose gold  
Weight : 115 gr

**COAT HOOK WITH LED V1831**



**Code** BCV1831

**Technical Specifications**

Material : Zamak ve ABS  
Color : Chrome  
Weight : 60 gr  
Lighting : LED  
Power : 12V  
Mounting : Surface mounted

**HIDDEN COAT HOOK - V2015**



**Code** BCV2015

**Technical Specifications**

Material : Zamak ve ABS  
Color : Chrome  
Weight : 95 gr  
Installation : Built-in

**HIDDEN COAT HOOK - V2015**



**Code** TCOV2015NEOP

**Technical Specifications**

Material : ABS  
Color : Matte black  
Installation : Built-in

**COAT HOOK - V1879**



**Code** BCV1879

**Technical Specifications**

Material : Zamak  
Color : Aluminum painted, bright chrome  
Weight : 90 gr

**COAT HOOK - V1879**



**Code** BKACAS1879COP

**Technical Specifications**

Material : Zamak  
Color : Mat rose gold  
Weight : 90 gr

Thanks to STS Oberholz locks, **you do not have to carry multiple keys, you can control all your locks with a single key!**

The risk of loss is at its lowest!

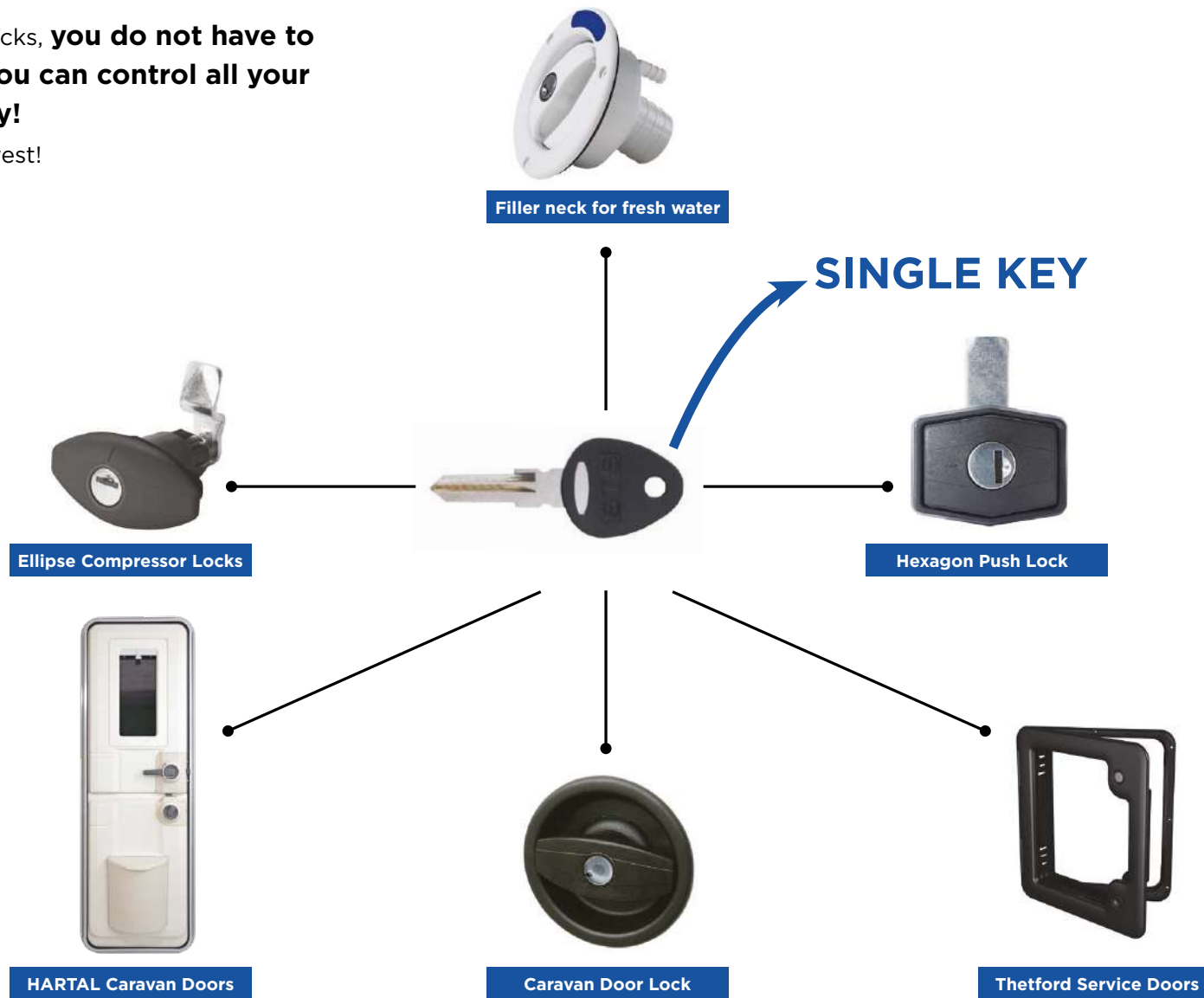



**COMPRESSION PUSH LOCK  
"ELLIPSE" 2007**



**Code** ST2007-20S3-80  
White (Small)



**Code** ST2007-20S3-840  
Black (Small)



**Code** ST2007-20S4-813  
White (Big)

- Compression push lock for compartment and garage doors
- Waterproof and corrosion-protected
- By turning the handle by 180°, the latch, with compression of 6 mm, pulls the flap to the seal
- Particularly smooth operation
- Locking cylinder inserts made of zamak or plastic for STS, Zadi and HSC plug-in cylinders

**FIXING PLATE**



**Code** ST2000-52-840

- Fixing plate for push lock
- Black color
- Product weight: 0.010 kg

**HEXAGONAL PUSH LOCK**



**Code** ST2002-0002A-840

- Black color
- Large hex nut
- Product weight: 0.120 kg

**LASHING EYE FOR LOAD  
SECURING**



**Code** ST9999-2010-840

- For suitcases, bicycles, prams etc.
- Retrofittable for all vehicles
- Robust in zamak
- Depending on the substrate, loadable up to 3000 N (300 kg)

**CARAVAN DOOR LOCK  
"EUROPA SERIES"**



**Code** ST9301-204-840

- Consisting of inner and outer lock in black
- For right or left versions
- Interior lock with knob or lever
- Locking cylinder inserts for STS and Zadi plug-in cylinders
- Insertable for wall thicknesses from 31 to 39 mm
- Various areas of applications possible, e.g. as lock for compartment, entrance doors or as a WC locking system

**BARREL**



**Code** ST7309-Z000-

- 100 different lock combinations

**2 KEYS**



**Code** ST7310-Z000-

- 2.5 mm

**FOLDING TABLE LEG - ASTRO 3**

**NEW**



**Code** LP2021104532

**Technical Specifications**

- Folding design for compact storage
- Telescoping option available
- Extruded, anodized aluminum to be strong and lightweight
- Rectangular tube profile
- Plastic hinge and top plate
- Customizable hinge position
- 720 x 40 mm

**SLIDING CONNECTION KIT - STILO**

**NEW**



**Code** LP2021104685

**Technical Specifications**

- Provides an adjustable bracket system to mount the table
- Sliding brackets easily adjust to accept different table dimensions
- Plastic and anodized aluminum construction for smooth operation

**FOLDING SUPPORT TABLE LEG - ASTRO**

**NEW**



**Code** LP2021104613

**Technical Specifications**

- Folding design for compact storage
- Extruded, anodized aluminum to be strong and lightweight
- Rectangular tube profile for a sturdy, functional accent
- Tough plastic hinge and top plate will never rust
- 720 x 40 mm

**TABLE LIFT SUPPORT- UPDOWN**

**NEW**



**Code** LP2021104685

**Technical Specifications**

- Pivoting bracket allows table to be positioned high or low as needed
- Extruded, anodized aluminum construction to be strong and lightweight
- Designed to install onto wall bracket (separately)

**TELESCOPIC TABLE LEG - COSMO**

**NEW**



**Code** LP2021104558  
4 Way

**Code** LP2021104554  
360°

**Technical Specifications**

- Plastic and aluminum slide components
- Steel construction for maximum strength
- Available with sliding and rotating table support

**TOSCANA - BED LIFTING SYSTEM**

**NEW**



**Code** LP2022002315

- Engineered to lift and / or lower in the rear garage, above the dinette or driver's seat
- High-performing gear motor with optional integrated encoder
- Lifting system fits completely under the bed frame and offers maximum fitting flexibility
- Heavy-duty yet lightweight aluminum frame with wooden slats
- Available with advanced control system to manage different positions
- Includes bed frame and lifting system
- Available with electric motor or manual crank option
- Available with wall fixing
  
- Static loading: 350 kg
- Lifting capacity 60 kg
- Amperage 9A - 20A
- Voltage 12V DC

**Technical Specifications**

Feature : 300 - 1500 mm stroke  
 Weight : 23 kg  
 Dimension(WxH): 2000x1300mm

**FIRENZE - SLIDING BED BASE**

**NEW**



**Code** LP2021104128

- Reclinable back for comfortable sleeping, reading, watching TV and relaxation
- Sliding design reduces overall dimensions while bed is not in use
- Available in manual, multi-position synchronized-assisted or electric option
- Heavy-duty yet lightweight aluminum frame with wooden slats
- Available with standard or comfort wooden slats

**Feature**

Dimension : 1350\*1900mm  
 Sliding : 1500 mm  
 Static Loading Capacity: 250 kg  
 Weight : 30kg

**COVERING - A1662**



**Code** NB-A1662-PL

Semi-finished panels made up of sheets of wood veneer glued together using the cross-grain method. The internal and external layers can be made with the same material or be veneered with more prestigious wood effect foils. The external B or BB quality sides are refined evenly so they can be covered with decorative paper, plastic foils, CPL or HPL.

Nobilpan's awareness in safeguarding the environment and natural resources, in addition to being FSC® certified, is summed up in the "Eco-Friendly by Nobilpan" brand, which reflects the company's choice in adopting certain policies that give real value to eco-sustainability:

- Continual control of the production process to reduce the impact on the environment within the minimal value range
- Close attention is paid in selecting raw materials with certified quality and origin traceability guaranteed
- Lamination with products that imitate wood or other surfaces, and which don't originate from deforestation
- High-precision numerically controlled cutting system that reduces waste and errors.
- Formaldehyde-free production methods
- Minimal energy consumption manufacturing process

• 1 plate is 2.98 square meters.

**Technical Specifications**

Plate Dimensions : 2440x1220 mm  
 Thickness : 2.7mm  
 Uses : Furniture and accessories, Interior Decoration, Doors, Walls and Ceilings, Cars, RVs, Houses, Mobile homes, Boat Building, DIY Projects

**GLADST - A1429**



**Code** NB-A1429-PL

Semi-finished panels made up of sheets of wood veneer glued together using the cross-grain method. The internal and external layers can be made with the same material or be veneered with more prestigious wood effect foils. The external B or BB quality sides are refined evenly so they can be covered with decorative paper, plastic foils, CPL or HPL.

Nobilpan's awareness in safeguarding the environment and natural resources, in addition to being FSC® certified, is summed up in the "Eco-Friendly by Nobilpan" brand, which reflects the company's choice in adopting certain policies that give real value to eco-sustainability:

- Continual control of the production process to reduce the impact on the environment within the minimal value range
- Close attention is paid in selecting raw materials with certified quality and origin traceability guaranteed
- Lamination with products that imitate wood or other surfaces, and which don't originate from deforestation
- High-precision numerically controlled cutting system that reduces waste and errors.
- Formaldehyde-free production methods
- Minimal energy consumption manufacturing process

• 1 plate is 3.05 square meters.

**Technical Specifications**

Plate Dimensions : 2500x1220mm  
 Thickness : 12mm  
 Uses : Furniture and accessories, Interior Decoration, Doors, Walls and Ceilings, Cars, RVs, Houses, Mobile homes, Boat Building, DIY Projects

**NAGANO - C1378**



**Code** NB-C1378-PL

Semi-finished panels made up of sheets of wood veneer glued together using the cross-grain method. The internal and external layers can be made with the same material or be veneered with more prestigious wood effect foils. The external B or BB quality sides are refined evenly so they can be covered with decorative paper, plastic foils, CPL or HPL.

Nobilpan's awareness in safeguarding the environment and natural resources, in addition to being FSC® certified, is summed up in the "Eco-Friendly by Nobilpan" brand, which reflects the company's choice in adopting certain policies that give real value to eco-sustainability:

- Continual control of the production process to reduce the impact on the environment within the minimal value range
- Close attention is paid in selecting raw materials with certified quality and origin traceability guaranteed
- Lamination with products that imitate wood or other surfaces, and which don't originate from deforestation
- High-precision numerically controlled cutting system that reduces waste and errors.
- Formaldehyde-free production methods
- Minimal energy consumption manufacturing process

• 1 plate is 3.05 square meters.

**Technical Specifications**

Plate Dimensions : 2500x1220 mm  
 Thickness : 12mm  
 Uses : Furniture and accessories, Interior Decoration, Doors, Walls and Ceilings, Cars, RVs, Houses, Mobile homes, Boat Building, DIY Projects

**PAVAROTTI - C1380**



**Code** NB-C1380-PL

Semi-finished panels made up of sheets of wood veneer glued together using the cross-grain method. The internal and external layers can be made with the same material or be veneered with more prestigious wood effect foils. The external B or BB quality sides are refined evenly so they can be covered with decorative paper, plastic foils, CPL or HPL.

Nobilpan's awareness in safeguarding the environment and natural resources, in addition to being FSC® certified, is summed up in the "Eco-Friendly by Nobilpan" brand, which reflects the company's choice in adopting certain policies that give real value to eco-sustainability:

- Continual control of the production process to reduce the impact on the environment within the minimal value range
- Close attention is paid in selecting raw materials with certified quality and origin traceability guaranteed
- Lamination with products that imitate wood or other surfaces, and which don't originate from deforestation
- High-precision numerically controlled cutting system that reduces waste and errors.

- 1 plate is 3.05 square meters.

**Technical Specifications**

Plate Dimensions : 2500x1220 mm  
 Thickness : 12mm  
 Uses : Furniture and accessories, Interior Decoration, Doors, Walls and Ceilings, Cars, RVs, Houses, Mobile homes, Boat Building, DIY Projects

**BARBERINO - C2116**



**Code** NB-C2116-PL

Semi-finished panels made up of sheets of wood veneer glued together using the cross-grain method. The internal and external layers can be made with the same material or be veneered with more prestigious wood effect foils. The external B or BB quality sides are refined evenly so they can be covered with decorative paper, plastic foils, CPL or HPL.

Nobilpan's awareness in safeguarding the environment and natural resources, in addition to being FSC® certified, is summed up in the "Eco-Friendly by Nobilpan" brand, which reflects the company's choice in adopting certain policies that give real value to eco-sustainability:

- Continual control of the production process to reduce the impact on the environment within the minimal value range
- Close attention is paid in selecting raw materials with certified quality and origin traceability guaranteed
- Lamination with products that imitate wood or other surfaces, and which don't originate from deforestation
- High-precision numerically controlled cutting system that reduces waste and errors.

- 1 plate is 3.05 square meters.

**Technical Specifications**

Plate Dimensions : 2500x1220 mm  
 Thickness : 12mm  
 Uses : Furniture and accessories, Interior Decoration, Doors, Walls and Ceilings, Cars, RVs, Houses, Mobile homes, Boat Building, DIY Projects

# CHASSIS SYSTEMS

Build your caravan on a safe and solid foundation.



**MODEL 2 CHASSIS (5190 MM - 1350 KG)**



**Code** JS23-161802

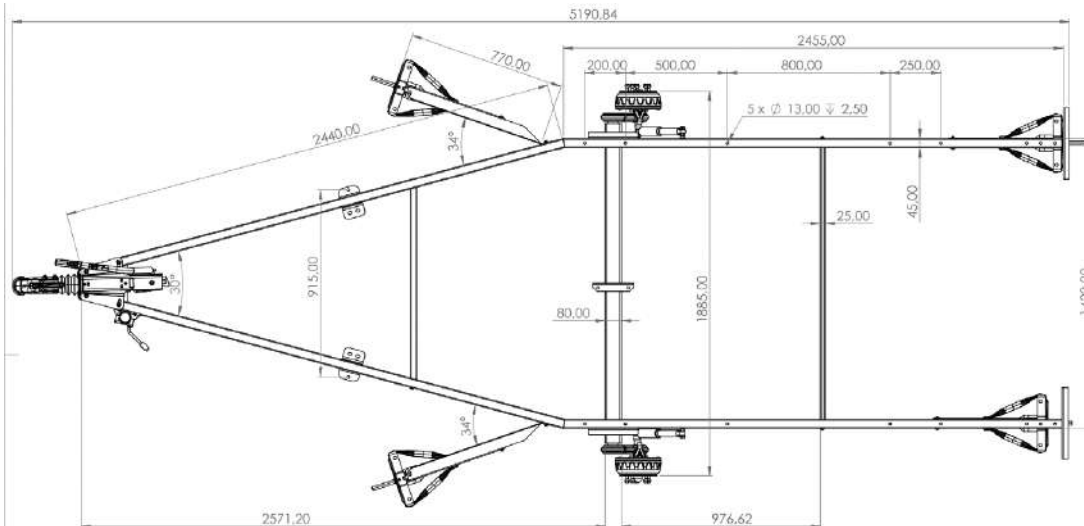

Four, not three, rubber elements surround the inner member of the axle to provide greater traction stability. Instead of crushing the tire, the inner element gently stretches it thanks to its unique shape: for a long service life and a significantly more comfortable ride.

**Why are four rubbers recommended?**

- Smart bead on the axle tube prevents the inner element from rotating in case of overload.
- Provides greater resistance to dangerous shaking.
- They surround a larger area of the internal element and prevent the axle from “steering”.
- Provides more stability.
- Better suspension characteristics and significantly more accurate suspension tuning

**Note: Please ask for special sizes.**

**AXLE SET WITH BRAKE**

**NEW**

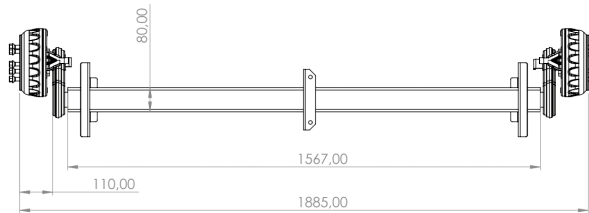
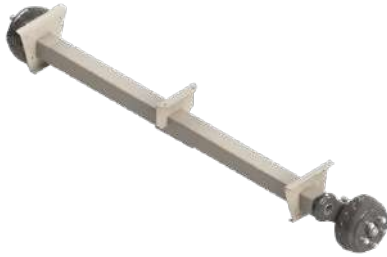

**Code** JD-A16135  
1350 kg

**Code** JD-A16105  
1050 kg

Thanks to the braked axle, when you brake, the rear brake axle also brakes and helps the vehicle slow down and stop.

**CARAVAN SUPPORT LEG**

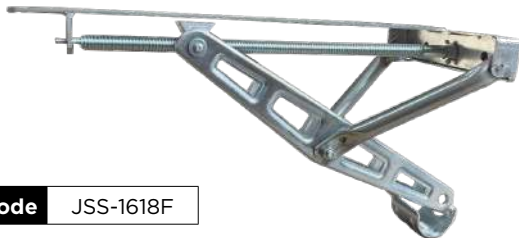

**Code** JSS-1618F

A caravan support leg is used for a safe and solid foundation.

**SUPPORT WHEEL AND HOLDER**

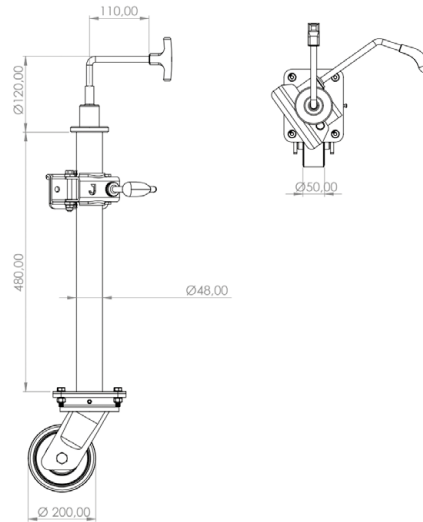

**Code** JW-161815  
Support Wheel

**Code** JDS-W1618  
Support Holder

Support wheels are used to steer the caravan. It is also useful for raising and lowering the caravan.

**BRAKE COUPLING**

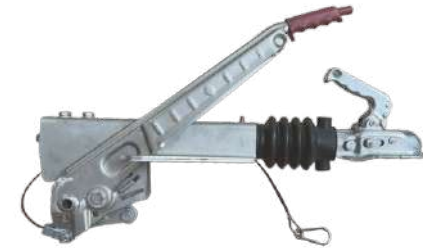

**Code** JFK-1618

**BRAKE LINKING BAR**



**Code** JFD-1618

**BOWDEN BRAKE CABLE**



**Code** JBK-1618



## 750 KG AXLE SET WITHOUT BRAKE

### AXLE SET WITHOUT BRAKE

**NEW**

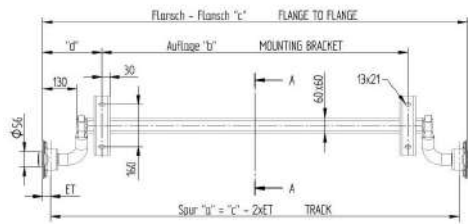

**Code** KN6A2036.021

#### Technical Specifications

Axle Type : VG7-L  
 Axle Load : 750 kg  
 Display Depth : 0 to 30 mm  
 Flange Size : 1850 mm  
 Weight : 25 kg  
 Wheel Mount : 100x4 mm  
 Support Size : 1400 mm

### COUPLING WITHOUT BRAKE

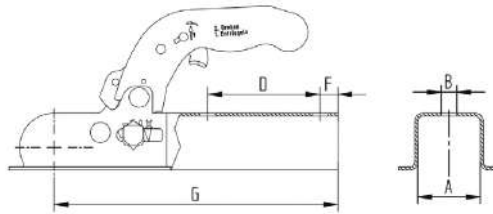

**Code** KN6E0081.045

#### Technical Specifications

Axle Type : VG7-L  
 Axle Load : 750 kg  
 Display Depth : 0 to 30 mm  
 Flange Size : 1850 mm  
 Weight : 25 kg  
 Wheel Mount : 100x4 mm  
 Support Size : 1400 mm

### SUPPORT WHEEL - TK48

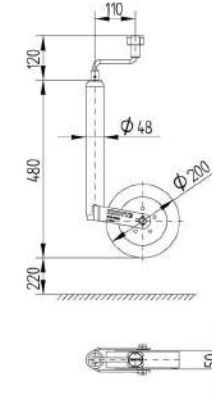

Support wheels are used to steer the caravan. It is also useful for raising and lowering the caravan.

**Code** KN-4802819X

#### Technical Specifications

Max static load capacity : 150 kg  
 Center : 220 mm  
 Surface treatment : Electro galvanized  
 Weight : 4.09 kg  
 Rim support : Sheet steel  
 External pipe diameter : 48 mm  
 Wheel size : 200x50mm

## CHASSIS SYSTEMS

### SUPPORT WHEEL HOLDER - LB48



**Code** KN-400305.001

#### Technical Specifications

Type : LB48  
 Diameter : 48 mm  
 Weight : 0.7 kg  
 Hole Pattern : 105/-- 2xØ11  
 Surface : Galvanized

# CHASSIS SYSTEMS

## AXLE SET WITH BRAKE

**NEW**



**Code** KN-4 09645.018

Thanks to the braked axle, when you brake, the rear brake axle also brakes and helps the vehicle slow down and stop.

## BOWDEN FREN KABLOSU

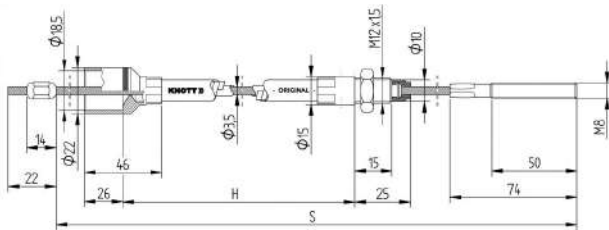

**Code** KN33921-1.16  
1640mm Length

**Code** KN33921-1.14  
1440mm Length

## BRAKE COUPLING

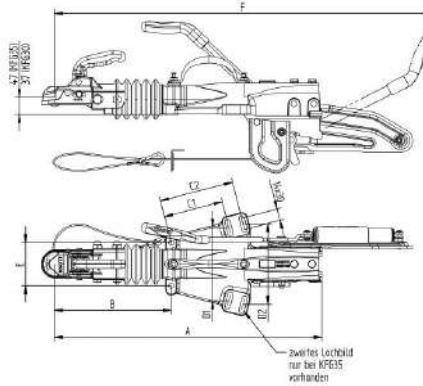

**Code** KN203090.001

### Technical Specifications

Allowed Total Weight	: 2700-3500 kg
Total Weight	: 3500 kg
Type	: KFG35-D
Support Load	: 150 kg
Port "A"	: 728 mm (Exempt until the end of the limb)
Port "B"	: 322 mm (Up to screw connection)
Rear hole pattern width "D"	: 200/225 mm
Handbrake lever length "F"	: 1031 mm
Weight	: 29 kg

# 1800 KG AXLE SET WITH BRAKE

## SUPPORT WHEEL - ATK60V

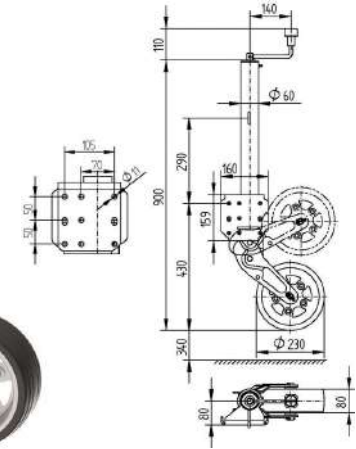

**Code** KN413455.001

Support wheels are used to steer the caravan. It is also useful for raising and lowering the caravan.

### Technical Specifications

Max static load capacity	: 500 kg
Center	: 340 mm
Surface treatment	: Galvanized
Weight	: 9.80 kg
Rim support	: Sheet steel
External pipe diameter	: 60 mm
Wheel diameter	: 230x80mm

## DOUBLE AXLE BRAKE LINK BAR



**Code** KN09907.001

## KS30 - STABILIZER



**Code** KN-209954.004

The stabilizing stabilizer KS30 is the only sure way to eliminate dangerous jerking movements of your caravan from the very beginning. They are especially used in caravans as they improve stability and increase safety levels. It allows you to tow your caravans more comfortably and much more safely.

### Technical Specifications

Model : KS30  
 Maximum weight : 3000 kg  
 Bolt : M12/M12, M14/M12, M14/M14  
 Connection : Ø35/Ø40/Ø45/Ø50 mm  
 Support load : 300 kg  
 Security screen : Yes  
 Part stabilization : Yes  
 Weight : 6,7 kg

## ANTI-THEFT DEVICE FOR KS 25/30/35



**Code** KN-210174.001

Anti-theft security system for stabilizers

### Technical Specifications

Type : KS 25/30/35  
 Weight : 0,35 kg

## ETS PLUS - ELECTRONIC STABILIZATION SYSTEM



**Code** KN-209200.002

ETS Plus reacts lightning fast with controlled braking in hazardous situations and reliably prevents rocking movements. State-of-the-art sensors and high-performance materials guarantee maximum safety, durability and reliability. Using special software, the data is precisely evaluated in real time - so that bumps on the road or similar standard situations do not trigger braking. Only when things get critical does he react with lightning speed.

### Technical Specifications

Minimum curb weight : 1000 kg  
 Maximum weight : 1800 kg  
 Wheel brakes type : 20-2425/1; 25-2025  
 Weight : 5,36 kg

# CHASSIS SYSTEMS

## TK48 SUPPORT WHEEL (STANDARD)



**Code** KN-4802819X

Support wheels are used to steer the caravan.  
It is also useful for raising and lowering the caravan.

### Technical Specifications

Max static load capacity : 150 kg  
Center : 220 mm  
Surface treatment : Electro galvanized  
Weight : 4,09 kg  
Rim support : Sheet steel  
External pipe diameter : 48 mm  
Wheel size : 200x50mm

## TK48 SUPPORT WHEEL (REINFORCED WHEEL)



**Code** KN- 411402.001

Support wheels are used to steer the caravan.  
It is also useful for raising and lowering the caravan.

### Technical Specifications

Max static load capacity : 150 kg  
Center : 220 mm  
Surface treatment : Galvanized  
Weight : 4,50 kg  
Rim support : Sheet steel  
External pipe diameter : 48 mm  
Wheel size : 225x65mm

## TK48 SUPPORT WHEEL (PREMIUM)



**Code** KN-419913.001

Support wheels are used to steer the caravan.  
It is also useful for raising and lowering the caravan.

### Technical Specifications

Max static load capacity : 150 kg  
Center : 220 mm  
Surface treatment : Electro galvanized  
Weight : 4,60 kg  
Rim support : Sheet steel  
External pipe diameter : 48 mm  
Wheel size : 200x50mm

## ST48 SUPPORT WHEEL



**Code** KN-408124.001

Support wheels are used to steer the caravan.  
It is also useful for raising and lowering the caravan.

### Technical Specifications

Max static load capacity	: 159 kg
Center	: 220 mm
Surface treatment	: Galvanizli
Weight	: 6,33 kg
Rim support	: Sheet steel
External pipe diameter	: 48 mm
Wheel size	: 225x70mm

## TURN-OUT SUPPORT (1000 KG)



**Code** KN-9885149205

A caravan support leg is used for a safe and solid foundation.

### Technical Specifications

Max. loading capacity	: 1000 kg
Center	: 500 mm
Hole Pattern	: 191/666 mm
Weight	: 4,54 kg

## SET OF SUPPORT PLATES



**Code** KN-423344.001

It is used to prevent the trailer support leg from sinking and slipping on wet or muddy ground. It provides extra security by fixing the caravan to the ground while it is parked.

### Technical Specifications

- Black, 4 piece
- Exit : 18x14x4,5
- Maksimum support load: 2000kg/plate
- Weight : 2 kg
- Hole Pattern : 191/666 mm
- Weight : 4,54 kg

## ALUMINIUM PANEL (1600x0.45 MM)



**Code** EMI053848



**We offer a wide array of products & services tailored to meet your needs**

### Temel malzeme özellikleri analığı

We coat a uniquely broad range of specifications on our two main production lines: our standard line and our wide paint line



**Coil width**



**Thickness**



**Alloys**







**Optional processing**

	Standard	Xtra-wide
Coil width	30 - 1,620 mm	850 - 2.630 mm
Thickness	0.3 - 2 mm	0.5 - 1,7 mm
Alloys	3000 series 5000 series Specialties	3000 series 5000 series Specialties
Optional processing	+ slitting + cutting + embossing	+ slitting + cutting + printing

### Our coating & processing services

We offer a wide range of highperformance coating options as well as many other value added processing steps

	<b>Technical pre-coating</b>	Variety of primers suitable for different kinds of processing
	<b>Aesthetic colour coating</b>	1,000+ colours, gloss levels and effect pigments in qualities ranging from PE to PVDF Lumiflon
	<b>Printed designs</b>	Any design is possible: From puristic stripe designs to wood surfaces to image printing
	<b>Embossing, slitting &amp; cutting</b>	3 different embossing designs Almost any size of cutting and slitting is possible
	<b>AluFiber/Stronglite</b>	Aluminium combined with fibre glass: superior surface, incomparable impact resistance. Stronglite: special alloy (light)

**(Precoated) Aluminium, the material of choice in recreational vehicle industry**

Euramax, strongly believes in the recreational vehicle industry due to its expected growth and need for sustainable, lightweight recyclable materials such as aluminium



**Light weight**

- 3 times lighter than Steel
- 1,3 times lighter than GRP
- Outstanding mechanical properties



**Cost efficient**

- 4 times cheaper than post painting
- 70% of value remaining on scrap market



**Superior aesthetics**

- No UV Aging
- No peeling effect



**Eco friendly**

- Can be recycled forever
- 3 times less negative effect on environment than post-painting



**Fire retardant**

- 2 times better performance in fire tests than GRP or related materials



**Simplified production**

- 80% production time is being saved by OEMS by integrating components in machined panels



**Corrosion resistant**

- Once oxidation layer has formed, the process stops



**Optimal adhesion**

- High Surface energy for optimal spreading of paint/glue
- 16 Mpa reached in shear strength test

**Our applications**

**Side panels**



**Roof panels**



**Front- & Back panels**



**Panels for doors en storage doors**



## LED LIGHTING SYSTEMS

---

- STOP LIGHTS
- SIGNAL LIGHTS
- REVERSING LIGHTS
- NUMBER PLATE LIGHTS
- REFLECTORS
- MARKER LIGHTS
- AMBIENT LIGHTS









## MULTIPLE FUNCTION LIGHT L 3600

The LED Multiple Function Light L 3600 is without any doubt a highlight in the now already more than 70 years lasting success story of our company and worthy successor of various trend-setting Jokon lights. An LED multiple function light designed according to the most modern aspects with integrated LED monitoring, optionally perfectly complementable by the also newly developed „BRIDGELIGHT®“, let your vehicle appear in a most modern design.

- LED multiple function light (LED-MFL)
- Variants with sequential indicator available (WBL)
- Integrated monitoring – SIM 100 (motor cars), SIM 2000 (trailer)
- Sealed in a waterproofed manner and ready for plug-in
- Can be supplemented by „Bridgelight“
- Customer exclusive design panel on request
- PC-ABS / PMMA
- Connector 2 x 3-pin Delphi



Product	Code / Model	Features	Voltage	Power	Installation	Monitoring	IP	Approval	
	<b>JK10.3200.011</b> WBBSNW 3600 LH	LED-MFL, Trailer Signal / Stop / Rear / Reverse / Fog	12 V	27/25/8/ 5/16 W	Horizontal 0-20°	SIM 2000	IP 67	E13-36079	
	<b>JK10.3200.021</b> WBBSNW 3600 RH	LED-MFL, Trailer Signal / Stop / Rear / Reverse / Fog	12 V	27/25/8/ 5/16 W	Horizontal 0-20°	SIM 2000	IP 67	E13-36080	
	<b>JK10.3200.511</b> WBBSNW 3600 LH	LED MFL, Motorcar Signal / Stop / Rear / Reverse / Fog	12 V	27/2/8/ 5/5 W	Horizontal 0-20°	SIM 100	IP 67	E13-36079	
	<b>JK10.3200.521</b> WBBSNW 3600 RH	LED MFL, Motorcar Signal / Stop / Rear / Reverse / Fog	12 V	27/2/8/ 5/5 W	Horizontal 0-20°	SIM 100	IP 67	E13-36080	
	<b>JK10.3230.011</b> BBSNW 3600 LH	LED-MFL, Trailer Signal / Stop / Rear / Reverse / Fog	12 V	27/25/8/ 5/16 W	Vertical	SIM 2000	IP 67	E13-36069	
	<b>JK10.3230.021</b> BBSNW 3600 RH	LED-MFL, Trailer Signal / Stop / Rear / Reverse / Fog	12 V	27/25/8/ 5/16 W	Vertical	SIM 2000	IP 67	E13-36069	
	<b>JK19.2053.000</b>	Deco Cover / 3600 Chrome	For all variants with horizontal mounting or vertical mounting with tail light function outside						
	<b>JK19.2053.100</b>	Deco Cover / 3600 Black							

## MULTIPLE FUNCTION LIGHT - L 3600 BLACK

**NEW**



- LED multifunction light (LED-MFL)
- Variants with sequential flashing lights (WBL)
- Integrated monitoring - SIM 100 (motor vehicles), SIM 2000 (trailer)
- Watertightly sealed and ready to install
- Can be supported with "Bridgelight"
- Customer-specific design panel upon request
- PC-ABS / PMMA
- 2x3-pin Connection, Delphi
- LED Signal/Stop/Rear/Reverse Gear/Fog

**Code** JK10.3200.211  
Left

**Code** JK10.3200.221  
Right

## BRIDGELIGHT L 50



Design draft, changes reserved,  
further information on request



Mounting option

**Code** JK13.0061.000

The innovative design of the L 50 Bridgelight allows customised dimensions in addition to the standard version. The homogeneously designed „luminous surface“ in combination with the variably mountable L 3600 multi-functional light gives the rear view of YOUR vehicle an unmistakable expression. It is a perfect extension to the trendsetter L 3600

- In addition to standard design, individual lengths possible
- Homogeneous tail light

## MULTIPLE FUNCTION LIGHT L 3000

**NEW**



**Code** JK10.2200.011  
Left

**Code** JK10.2200.021  
Right

The lights of the series 3000 were developed for recreational vehicles that require horizontal mounting. The result is a characteristic slim multi-function light with bulb technology and all light functions including reflector or triangular reflector. Depending on the version, it can therefore be used for both: motorcaravans and caravans.

- 2-colour lens (red/clear), housing grey
- Incl. fitted 12 V bulbs
- Turn signal light / Brake light / Tail light / Rear fog light / Reversing lamp / Reflector triangle

### Technical Specifications

Usage : LED Signal/Stop/Rear/Reflector  
Voltage : 12 V  
Color : Red  
Connection : 500 mm cable  
IP : IP 67  
Approval : E1-3557  
Model : BBSR 935/ 12V

## MULTIPLE FUNCTION LIGHT L 3100

**NEW**



**Code** JK10.2240.011  
Left

**Code** JK10.2240.021  
Right

The lights of the series 3100 were developed for recreational vehicles that require vertical mounting. The result is a slim, high-build multi-function light with bulb technology and all light functions including reflector or triangular reflector. Depending on the version, it can therefore be used for both: motor caravans and caravans. Further variants with LED tail light function and dark colored lenses are available.



- Flush fitting vertically
- 2-colour lens (red/clear), housing grey
- Incl. fitted 12 V bulbs
- Additional variants with LED tail light functions available
- Turn signal light / Stop light / Tail light / Fog light / Reverse light / Reflector



## MULTIPLE FUNCTION LIGHT L 915

The LED usage of the Multiple Function Light L 915 enables an extremely compact light. The result is a very flat LED multifunctional light with all lighting functions including 2 reflector versions. Its neutral and modern design makes it suitable for many different types of vehicles.



- Non visible membrane for thermodynamic balance
- With chrom-plated design part
- 9-16V; S-2W; BR-3.0W; BL-4.0W; SN-7.0W; W-5.0W
- 9-32V; S-1,5W; BR-3,0W; BL-3,0W; SN-4,5W; W-3,0W

Product	Code / Model	Features	Voltage	Material/Color	Connection	IP	Approval
	<b>JK10.2400.111</b> BBSNWR 915b / 9-16V LH	LED Signal / Stop / Rear / Reverse / Fog / Reflector	9-16 V	PC Red-Clear	Centr. connector	IP 67	E13-13359 EMV / EMC
	<b>JK10.2400.121</b> BBSNWR 915 b/ 9-16V RH	LED Signal / Stop / Rear / Reverse / Fog / Reflector	9-16 V	PC Red-Clear	Centr. connector	IP 67	E13-13359 EMV / EMC
	JK10.2440.110 BBSNWDR 915b / 9-16V LH	LED Signal / Stop / Rear / Reverse / Fog / Reflector	9-16 V	PC Red-Clear	Centr. connector	IP 67	E13-13359 EMV / EMC
	<b>JK10.2440.120</b> BBSNWDR 915b / 9-16V RH	Signal / Stop / Rear / Reverse / Fog / Reflector	9-16 V	PC Red-Clear	Centr. connector	IP 67	E13-13359 EMV / EMC



Accessories / Spare Parts								
	<b>JK62.3001.002</b> LK 100b-1/12V	LED Controller (DI)	12 V	2x21 W	Aluminum / PU Black	2 x 1500 mm cable	IP 67	EMV / EMC
	<b>JK62.3002.012</b> LK 100-1/24V	LED Controller (DI)	24 V	2x21 W	Aluminum / PU Black	2 x 1500 mm cable	IP 67	EMV / EMC
	<b>JK62.3020.100</b> LK 2000-1/12V	LED Controller	12 V	max. 140 W	Aluminum / PU Black	1x 1500 mm cable 1x 2500 mm cable	IP 67	EMV / EMC

## MULTIPLE FUNCTION LIGHT L 920

Highlights of this newly developed multiple function light are the integrated monitoring simulations to ensure trailer recognition by the towing vehicle, the proven Jokon LEDDefect- Control-Circuit and the modern design with sequential indicator and homogenous tail light. A separate control box for function monitoring is generally no longer necessary. Developed in well-known Jokon quality and design, all legal requirements are of course fulfilled.



- Compact and attractive design
- Sequential wiper indicator
- Incl. hidden membrane to balance thermodynamics
- DI function: with LDC (LED-Defect-Control)
- Integrated simulation

Product	Code / Model	Features	Voltage	Material/Color	Connection	IP
	<b>JK10.3500.011</b> BBSNWDR 920 li / LH	LED Signal / Stop / Rear / Reverse / Fog / Reflector	12 V	PC Red-Clear	Centr. connector	IP 67
	<b>JK10.3500.021</b> BBSNWDR 920 re / RH	LED Signal / Stop / Rear / Reverse / Fog / Reflector	12 V	PC Red-Clear	Centr. connector	IP 67
	<b>JK10.3500.111</b> BBSKWDR 920 li / LH	LED Signal / Stop / Rear / Reverse / Fog / Reflector / Number Plate Lamp	12 V	PC Red-Clear	Centr. connector	IP 67
	<b>JK10.3500.121</b> BBSKWDR 920 re / RH	LED Signal / Stop / Rear / Reverse / Fog / Reflector / Number Plate Lamp	12 V	PC Red-Clear	Centr. connector	IP 67

## MULTIPLE FUNCTION LIGHT L 930



**Code** JK10.2300.402

LED usage enables an extremely compact light. The result is a very flat multifunctional LED light with all light functions including reflex-reflector. Because of the modern and neutral design the light fits perfectly to a lot of different vehicle types.

- Mounting: horizontally or vertically
- 2-colour PC lens (red / clear), housing PC black
- Surface mounting or flush fitting: horizontally
- Non visible membrane for thermodynamic balance
- With chrom-plated design part
- 9-32V; S-1W; BR-2W; BL-3W; SN-3W; W-4W
- 12V; S-2W; BR-2W; BL-4W; SN-4W; W-5W
- 24V; S-1W; BR-2W; BL-3W; SN-2W; W-3W

### Technical Specifications

Usage : LED Signal/Stop/Rear/Reverse Gear/Fog/Reflector  
 Voltage : 12 V  
 Color : Red  
 Connection : 500 mm cable  
 IP : IP 67  
 Approval : E1-3110 EMV / EMC  
 Model : BBSNWR 930b/12V

### MULTIPLE FUNCTION LIGHT L 935



**Code** JK10.2600.002

The L 935 is a very small LED multiple function light with direction indicator, stop and tail light and reflex reflector. The light can be mounted vertically or horizontally. The very large number of LEDs - combined in a distinctive shape - ensures high security on the road and guaranteed recognition of your vehicle.

- LED multiple function light with integrated reflex reflector
- 2-colour PC lens (red / clear), housing PC black
- installation from rear (M6 screw) or front (ST4,8)
- Mounting: horizontally or vertically
- 12 and 24V version; TL-3 W; ST-6 W; DI-5 W
- With chrome-plated design part
- Incl. non visible membrane for thermodynamic balance
- DI function: combination with LK 100-2-X possible

#### Technical Specifications

Usage : LED Signal/Stop/Rear/Reflector  
 Voltage : 12 V  
 Color : Red  
 Connection : 500 mm cable  
 IP : IP 67  
 Approval : E1-3557  
 Model : BBSR 935/ 12V

### MULTIPLE FUNCTION LIGHT L 940



**Code** JK10.3000.000

L 940 is the successor generation of the existing and successful L 930. Extremely efficient and high-quality brand-name LEDs combined with a design that meets high demands. Dimensions are the same.

- Designed for surface or (deepened) flush mounting
- Incl. hidden membrane to balance thermodynamics
- DI function: with LDC (LED-Defect-Control) for combination with LK control device
- Design cover for masking the fastening screws

#### Technical Specifications

Usage : LED Sinyal/Stop/Arka/Geri Vites  
 /Sis/Reflector  
 Voltage : 12 V  
 Color : PC Red  
 Connection : 500 mm cable  
 IP : IP 67  
 Model : BBSWNR 940/12V



**LED LIGHTING SYSTEM L 112**



Product	Code / Model	Features	Voltage	Power	Material/Color	Connection	IP	Approval
	<b>JK10.1042.000</b> BBS 112/12V	LED Signal / Stop / Tail Light	12 V DC	3/5/5 W	PC: Red / ABS-PC: Black	500 mm cable	IP 67	E13-35099

The L 112 lighting system with an outer diameter of 112 mm represents a successful symbiosis of Saphira lighting technology and fully homogeneous diffuser optics for the taillight function. The LED lights are ready for plug-in, waterproof sealed, equipped with a non-visible membrane for thermodynamic balance and have a connecting cable of 500 mm length. The lights are suitable for surface mounting and flush mounting. Together with SNWS 115 double tail light function with corresponding D-approval (ECE R48).

**LED LIGHTING SYSTEM L 115**





Product	Code / Model	Features	Voltage	Power	Material/Color	Connection	IP	Approval
	<b>JK10.1043.000</b> BBS 115/12V	LED Signal / Stop / Tail Light	12 V	4/3/3 W	PMMA / PC/ ABSS	500 mm cable	IP 67	E13-35099

The LED lights type L 115 with homogeneous tail light function, single wire sealing and a Goretex membrane for pressure compensation or moisture dissipation. Screw holes are concealed by the decorative chrome ring. In conjunction with SNWS 115 double tail light function, of course with corresponding D approval (ECE-R 48).

### LED LIGHTING SYSTEM L 790





Product	Code / Model	Features	Voltage	Material/Color	Connection	IP	Approval
	<b>JK10.0054.500</b> BBS 790/12V	LED Signal / Stop / Tail Light	12 V	PC / PC-ABS Red, clear	500 mm cable	IP 67	E13-34661 E13-34665
	<b>JK10.0054.800</b> BBSR 790/12V	LED Signal / Stop / Tail Light	12 V	PC / PC-ABS Red, clear	500 mm cable	IP 67	E13-34661 E13-34665
	<b>JK13.3116.000</b> SNWR 790/12V	LED Fog / Reversing / Reflector	12 V	PC / PC-ABS Red, clear	500 mm cable	IP 67	E13-34811 E13.34810

Latest lighting technology available as modular series of round shaped light with a diameter of 122mm. The special structure of the surface of the optical lense creates an homogeneous light pattern. Quick & Easy fixture: an adapter plate screwed on the vehicle allows to mount the light from the exterior (optional: stud bolts). Available in 12V or 24V variants.

- LED multifunction light with total-reflexion optic
- Surface mounting with bayonet joint (alternatively with bolts)
- Quick assembly and disassembly through locking pin
- Double sealed for optimal waterproofness.
- Incl. hidden membrane to balance thermodynamics
- EMC approval
- DI function: with LDC (LED-Defect-Control) for combination with LK control device

### LED LIGHTING SYSTEM L 720



Product	Code / Model	Features	Voltage	Power	Material/Color	Connection	IP	Approval
	<b>JK10.0008.000</b> BRS 720/12V	LED Stop / Tail Light	12 V	3,7 / 0,6 W	PC / ABS Red	180 mm cable	IP 67	E2-203037
	<b>JK13.1021.000</b> BL 720/12V	LED Signal Light	12 V	3,8 W	PC / ABS Yellow	180 mm cable	IP 67	E2-0103038
	<b>JK13.6012.000</b> W 720/12V	LED Reversing Light	12 V	6,3 W	PC / ABS Clear	180 mm cable	IP 67	E2-0004035

LED Lights type 720 are ready for plug-in, they are sealed in a waterproof manner and are equipped with a connecting cable of 180 mm. They can be extended by a decoration rim to a diameter of 122 mm available in different colours. These lights are used for flush fitting, but because of their small installation depth they can be used for surface mounting as well.







- Sealed in a waterproof manner and ready for plug-in
- Flush fitting or surface mounting

## LED LIGHTING SYSTEM L 250





The L250 is a very compact LED light, which can be mounted in any angle (X-axis or vehicle longitudinal central axis) (except WBL250). This allows to design very distinctive vehicle rear ends. Can be used on vehicles with both 12 V and 24 V on-board voltage (9-32 V versions).

- Can be mounted in any angle (360°/X-axis)
- Incl. lateral covers ( chrome-plated or like lens dep. on version)
- Installation either from the back (M5 screw) or from the front
- Surface mounting or flush mounting
- Single wire insulation for perfect water tightness
- Incl. non visible membrane for thermodynamic balance

Product	Code / Model	Features	Voltage	Power	Material/Color	Connection	IP	Approval
	<b>JK10.0063.000</b> BRS250/12V	LED Stop / Tail Light Homogeneous	12 V DC	2,0 / 0,3 W	PC/ABS-PC: Red Cover: Chrome	500 mm cable	IP 67	E13-35447
	<b>JK13.0023.000</b> S 250/12V	LED Tail Light Homogeneous	12 V DC	0,3 W	PC/ABS-PC: Red Cover: Chrome	500 mm cable	IP 67	E13-35447
	<b>JK10.0045.000</b> BRS 250/9-32V	LED Stop / Tail Light	9-32 V DC	2,0 / 0,3 W	PC/ABS-PC: Red Cover: Chrome	500 mm cable	IP 67	E13-13262 EMV / EMC
	<b>JK13.2006.000</b> BR 250/9-32V	LED Stop Light	9-32 V DC	2,2 W	PC/ABS-PC: Red Cover: Chrome	500 mm cable	IP 67	E13-13261 EMV / EMC
	<b>JK13.2008.600</b> BR 250/12V	LED Stop Light	12 V DC	2,2 W	PC/ABS-PC: Clear Cover: Chrome	500 mm cable	IP 67	E13-13261 EMV / EMC
	<b>JK13.6037.000</b> W 250/12V	LED Reversing Light	12 V DC	5 W	PC/ABS-PC: Clear Cover: Chrome	500 mm cable	IP 67	E13-13360 EMV / EMC
	<b>JK15.0018.100</b> ZHBL 250b/9-32V	LED High Level Stop Light	9-32 V DC	10 W	PC/ABS-PC: Red Cover: Red	500 mm cable	IP 67	E13-13365 EMV / EMC
	<b>JK31.0017.000</b> R 250 r/cr	Reflector			PC/ABS-PC: Red Cover: Chrome		IP 67	E13-13361

### Aksesuarlar / Yedek Parçalar

Product	Code / Model	Features	Voltage	Power	Material/Color	Connection	IP	Approval
	<b>JK19.2035.000</b>	Covers (pair) Chrome						
	<b>JK19.2035.100</b>	Covers (pair) Red						
	<b>JK62.3001.002</b> LK 100b-1/12V	LED Kontrol Cihazı (DI)	12 V	2x21 W	Black	2x1500 mm cable	IP 67	EMV
	<b>JK62.3002.012</b> LK 100-1/24V	LED Kontrol Cihazı (DI)	24 V	2x21 W	Black	2x1500 mm cable	IP 67	EMV



### LED SIDE MARKER LIGHT SMLR 2019



LED-side-marker-light (9-32 V) with integrated reflex-reflector and 3 LEDs, very flat design, adhesive fastening.

Product	Code / Model	Features	Voltage	Power	Material/Color	Connection	IP	Approval
	<b>JK12.1017.000</b> SLMR 2019-1/12V	LED Side Marker Light	12 V	1 W	PMMA / ABS	500 mm cable	IP 67	E13-35915
	<b>JK12.1017.100</b> SLMR 2019-1/12V	LED Side Marker Light	12 V	1 W	PMMA / ABS	250 mm cable	IP 67	E13-35915

### LED FRONT MARKER LIGHT PLR 2019



LED-position lights (9-32 V) with integrated reflex-reflector and 3 LEDs, very flat design, adhesive fastening.

Product	Code / Model	Features	Voltage	Power	Material/Color	Connection	IP	Approval
	<b>JK11.1025.000</b> PLR 2019/9-32V	LED Front Marker Light	9-32 V	1 W	PMMA / ABS Clear	800 mm cable	IP 6K9K	E13-24816 EMV / EMC

- Compact and attractive design
- Installation from rear with automotive 3M self-adhesive tape
- Can be mounted in any angle (360°/X-axis)
- Designed for surface or (deepened) flush mounting

### LED FRONT MARKER LIGHT PLR 2002



Product	Code / Model	Features	Voltage	Power	Material/Color	Connection	IP	Approval
	<b>JK11.1010.100</b> PLR 2002	LED Front Marker Light	12 V	0,6 W	PMMA / ABS Clear	100 mm cable	IP 6K9K	E2-2033 E2-0062

Series 2002 position-lights have an integrated reflector, are available in 12 V, 24 V and 12/24 V versions available.

## LED LIGHTING SYSTEM PL 40





Product	Code / Model	Features	Voltage	Power	Material/Color	Connection	IP	Approval
	<b>JK13.5031.000</b> PL 40/12V	LED Front Marker Light	12 V	1 W	PMMA / ABS	250 mm cable	IP 67	E1-5204
	<b>JK13.5031.010</b> PL 40/12V	LED Front Marker Light	12 V	1 W	PMMA / ABS	5000 mm cable	IP 67	E1-5204

Innovative LED single function lights with homogeneous light emission surface in 12 V or 24 V version.

- Compact and attractive design
- Installation from rear with automotive 3M self-adhesive tape
- Can be mounted in any angle (360°/X-axis)
- Designed for surface or (deepened) flush mounting

## FRONT MARKER LIGHT PLR 272



Product	Code / Model	Features	Voltage	Power	Material/Color	Connection	IP	Approval
	<b>JK11.1003.000</b> PLR 272	Front Marker Light	12-24 V	C 5 W	PMMA / ABS Clear	Blade terminals		E1-0221633 E1-0221378
	<b>JK13.5008.000</b> PLR 272	Front Marker Light	12 V	C 5 W	PMMA / ABS Clear	Blade terminals		E1-21625

Innovative LED single function lights with homogeneous light emission surface in 12 V or 24 V version.

## LED NUMBER PLATE LIGHT K 575



The very compact K 575 LED number plate light allows plugin replacement of the K 570 bulb light with the same dimensions. An excellent price/performance ratio supports the upgrade to LED technology.

- Flush fitting
- Sealed in a waterproofed manner and ready for plug-in

Product	Code / Model	Features	Voltage	Connection	IP
	<b>JK13.4019.000</b> K 575/12V	LED Number Plate Light	12 V	200 mm cable	IP 67

## NUMBER PLATE LIGHT K 97



- Surface mounting
- Festoon-type bulbs

Product	Code / Model	Features	Voltage	Connection	IP
	<b>JK13.4019.000</b> K 97	LED Number Plate Light	12 V	200 mm cable	IP 67

## NUMBER PLATE LIGHT K 307



- Surface mounting
- Silver-coloured housing
- Festoon-type bulbs

Product	Code / Model	Features	Voltage	Connection	IP
	<b>JK13.4019.000</b> K 307	LED Number Plate Light	12 V	200 mm cable	IP 67

## LED HIGH LEVEL STOP LIGHT ZHBL 40S / ZHBL 40L



**ZHBL 40S**

Product	Code / Model	Features	Voltage	Power	Material/Color	Connection	IP	Approval
	<b>JK15.0029.000</b> ZHBL 40S/12V	LED Stop Light	12 V	3 W	PMMA / ABS	250 mm cable	IP 67	E1-5206
	<b>JK15.0029.010</b> ZHBL 40S/12V	LED Stop Light	12 V	3 W	PMMA / ABS	4000 mm cable	IP 67	E1-5206

Innovative LED high level stop lights (chmsl) with homogeneous light emission surface over the entire light width in two construction sizes and 12 V or 24 V versions.

- Compact and attractive design
- Installation from rear with automotive 3M self-adhesive tape
- Designed for surface or (deepened) flush mounting



**ZHBL 40L**

Product	Code / Model	Features	Voltage	Power	Material/Color	Connection	IP
	<b>JK15.0031.000</b> ZHBL 40L/12V	LED Stop Light	12 V	3 W	PMMA / ABS	200 mm cable	IP 67

## LED HIGH LEVEL STOP LIGHT ZHBL 28



Product	Code / Model	Features	Voltage	Power	Material/Color	Connection	IP	Approval
	<b>JK15.0028.000</b> ZHBL 28/12V	LED Stop Light	12 V	1 W	PMMA / ABS Red	500 mm cable	IP 67	S3 E13-0235398

LED high level stop lights type 28 with SMT-LEDs are ready for plug-in, they are sealed in a waterproof manner and are equipped with a connecting cable of 500 mm.

- Screw holes covered by cover caps
- Low profile

**LED HIGH LEVEL STOP LIGHT ZHBL 25**



Product	Code / Model	Features	Voltage	Power	Material/Color	Connection	IP	Approval
	<b>JK15.0025.002</b> ZHBL 25/12V	LED Stop Light	12 V	16 W	PMMA / ABS Red	250 mm cable	IP 67	S3 E2- 0205026

LED high level stop lights type 25 are ready for plug-in, they are sealed in a waterproof manner and are equipped with a connecting cable of 250 mm.

- 12 V and 24 V types available
- Low profile
- Screw holes covered by cover caps

**LED HIGH LEVEL STOP LIGHT ZHBL 24-2**



Product	Code / Model	Features	Voltage	Power	Material/Color	Connection	IP	Approval
	<b>JK15.0024.502</b> ZHBL 24-2/12V	LED Stop Light	12 V	2,7 W	PMMA Red	250 mm cable	IP 67	S3 E2- 0204024

LED high level stop lights type 24-2 are ready for plug-in, they are sealed in a waterproof manner and are equipped with a connecting cable of 250 mm.

- 12 V and 24 V types available
- Low profile
- Screw holes covered by cover caps

**LED TAIL LIGHT SR 2002**



Product	Code / Model	Features	Voltage	Power	Material/Color	Connection	IP	Approval
	<b>JK13.0050.100</b> SR 2002/12	LED Tail Light / Reflector	12 V	0,6 W	PMMA / ABS Red	100 mm cable	IP 67	E2-2021 E2-0062

Series 2002 tail lights have an integrated reflector, are available in 12 V or 24 V versions and have a 100 mm connection cable fitted with flat tabs.

- SAE DOT / FMVSS approval for North America
- Surface mounting
- Sealed in a waterproof manner and ready for plug-in

**LED LIGHTING SYSTEM L 40**



Product	Code / Model	Features	Voltage	Power	Material/Color	Connection	IP	Approval
	<b>JK13.0059.000</b> S 40/12V	LED LED Tail Light	12 V	1 W	PMMA / ABS	250 mm cable	IP 67	E1-5205
	<b>JK13.0059.010</b> S 40/12V	LED LED Tail Light	12 V	1 W	PMMA / ABS	5000 mm cable	IP 67	E1-5205

Innovative LED single function lights with homogeneous light emission surface in 12 V or 24 V version.

- Compact and attractive design
- Installation from rear with automotive 3M self-adhesive tape
- Can be mounted in any angle (360°/X-axis) - except ZHBL
- Designed for surface or (deepened) flush mounting

**LED BRIDGELIGHT S 50**



**Code** JK13.0061.000

The innovative design of the L 50 Bridgelight allows customised dimensions in addition to the standard version. The homogeneously designed „luminous surface“ in combination with the variably mountable L 3600 multi-functional light gives the rear view of YOUR vehicle an unmistakable expression. It is a perfect extension to the trendsetter L 3600 (see page 30/31). Of course, L 50 Bridgelight

- In addition to standard design, individual lengths possible
- Homogeneous tail light

**Technical Specifications**

Usage : LED Tail Light  
 Voltage : 12 V  
 Color : Red  
 Connection : 500 mm cable  
 IP : IP 67  
 Model : S 50/12V

*Design draft, changes reserved, further information on request*

### TRIANGULAR REFLEX REFLECTOR DR 110



- One optical element
- Oval design

Product	Code / Model	Features	Material/Color	Approval
	<b>JK32.0001.020</b> DR 110	Triangular Reflex Reflector	PMMA - ABS Red	E1-021352

### TRIANGULAR REFLEX REFLECTOR DR 107



Product	Code / Model	Features	Material/Color	Connection	Approval
	<b>JK32.0006.000</b> DR 107	Triangular Reflex Reflector	PMMA - ABS Red, Black	Self-adhesive tape	E13-35126

### 13-PIN PLUG





Product	Code / Model	Features	Voltage	Material/Color	Connection	Özellik
	<b>JK45.0001.000</b>	13-Pin Plug	12 V	Plastic - Black	screw terminals	ISO 11446

### 13-PIN SOCKET



Product	Code / Model	Features	Voltage	Material/Color	Connection	Features
	<b>JK46.0006.000</b>	13-Pin Socket	12 V	Plastic - Black	Screw terminals	ISO 11446

### LED CONTROLLER (DI)

Product	Code / Model	Features	Özellik	Voltage	Power	Material/Color	Connection	IP	Approval
	<b>JK62.3001.032</b> LK 100-3/12V	LED Control Device	45mA (I = const.)	12 V	2x21 W	Aluminium Black	2x1500mm cable	IP 67	EMV / EMC
	<b>JK62.3001.022</b> LK 100-2/12V	LED Control Device Suitable for light: BBS 280/12V	90mA (I = const.)	12 V	2x21 W	Aluminium Black	2x1500mm cable	IP 67	EMV / EMC

In case of an LED failure, the power resistor is turned off and indicates the failure caused by lack of power.

## REFLECTOR - R 118



Product	Code / Model	Features	Material/Color	Connection	Approval
	<b>JK31.0005.501</b> R 118 r	Reflex Reflector	PMMA - ABS Red	Self-adhesive tape	IA E9 024006
	<b>JK31.0005.511</b> R 118 g	Reflex Reflector	PMMA - ABS Yellow	Self-adhesive tape	IA E9 024006
	<b>JK31.0005.521</b> R 118 w	Reflex Reflector	PMMA - ABS White	Self-adhesive tape	IA E9 024006

The use of LED provides an extremely compact light. It is a multifunctional LED light with all light functions including reflector. Thanks to its modern and simple design, the light fits perfectly into many different vehicle types.

## REFLEX REFLECTOR R 16



Product	Code / Model	Features	Material/Color	Connection	Approval
	<b>JK30.0001.000</b> R 16 r	Reflector	PMMA - ABS Red	Self-adhesive tape	IA E1- 0231306
	<b>JK30.0001.010</b> R 16 g	Reflector	PMMA - ABS Yellow	Self-adhesive tape	IA E1- 0231306
	<b>JK30.0001.020</b> R 16 w	Reflector	PMMA - ABS White	Self-adhesive tape	IA E1- 0231306

## REFLECTOR - R 17



Product	Code / Model	Features	Material/Color	Connection	Approval
	<b>JK30.0002.000</b> R 17 r	Reflector	PMMA - ABS Red	With plastic frame and mounting bolt M5x16	IA E1- 0231306
	<b>JK30.0002.010</b> R 17 g	Reflector	PMMA - ABS Yellow	With plastic frame and mounting bolt M5x16	IA E1- 0231306
	<b>JK30.0002.020</b> R 17 w	Reflector	PMMA - ABS White	With plastic frame and mounting bolt M5x16	IA E1- 0231306



**LED AWNING / PREFIELD / AMBIENT LIGHT WW 350**



Product	Code / Model	Features	Voltage	Power	Material/Color	Connection	IP
	<b>JK14.1022.000</b> WW 350/12V	LED Awning / Prefield Light	12 V	5 W 1,2 W	ASA/PC White 249	500 mm cable	IP 67

Design-oriented LED awning light with additional ambient lighting (upwards light output). 30 LEDs for the awning lighting and 18 LEDs for the ambience function in neutral white, combined with the homogeneous design of the illuminated surfaces, create a comfortable lighting. The technically high-quality design of this innovative awning-light is complemented by individually/exclusively selectable colour variants on request.

- Luminous flux awning light approx. 315 Lumen, ambient approx. 100 Lumen
- Colour temperature neutral white (approx. 3800 K)
- Incl. concealed membrane for thermodynamic balance

**LED AWNING / PREFIELD / AMBIENT LIGHT WW 250**



**Code** JK14.1007.000

The WW 250 LED lights offer more than just brightness: they appeal by an exclusive and elegant design which is still pleasantly discreet. The light distribution is extremely even owing to a rotationally symmetrical optical system, so that nothing remains in the "dark".

- LED awning / prefield light with 12 white high-power LED's
- Luminous flux approx. 250 Lumen (approx. 35W GU10 halogen bulb)
- Beam angle ahead: 0...90° / lateral -45...+45°
- Designed for surface mounting
- Installation from rear (M5 screw) or front (ST 4,2)

**C-LINE USB A AND USB C**



**Code** WS4104330

**Technical Specifications**

Voltage : 10-24V DC  
Polarity sensitive : Yes  
Max. output voltage : 5V DC  
Max. current (USB A) : 2.4A  
Output Voltage USB C : 5V/9V/12V DC  
Output current (USB C) : 3A/2A/1,5A  
Dimensions (LxW) : 53x53mm  
Installation height : 28mm

**C-LINE TOUCH DIMMER**



**Code** WS4103730

**Technical Specifications**

Voltage : 12V DC  
Max. current : 4A  
Dimensions (LxW) : 53x53mm  
Installation height : 10mm

**C-LINE SOCKET 230V  
SCHUKO MODULAR+COVER**



**Code** WS4104030

**Technical Specifications**

Voltage : 220V AC  
Max. current : 16A  
Dimensions (LxW) : 53x53mm  
Installation height : 28mm

**C-LINE TWO-WAY  
SWITCH 230V**



**Code** WS4103330

**Technical Specifications**

Voltage : 220V AC  
Max. current : 16A  
Dimensions (LxW) : 53x53mm  
Installation height : 12mm

**C-LINE DOUBLE  
SWITCH 230V**



**Code** WS4100830

**Technical Specifications**

Voltage : 220V AC  
Max. current : 16A  
Dimensions (LxW) : 53x53mm  
Installation height : 12mm

**OPAL SINGLE FRAME**



**Code** WS4101130 / Black  
**Code** WS4101140 / Grey

**Technical Specifications**

Material : ABS  
Dimensions (LxWxH) : 60x60x9mm

**OPAL DOUBLE FRAME**



**Code** WS4101230 / Black  
**Code** WS4101240 / Grey

**Technical Specifications**

Material : ABS  
Dimensions (LxWxH) : 117,5x60x9mm

**OPAL TRIPPLE FRAME**



**Code** WS4101330 / Black  
**Code** WS4101340 / Grey

**Technical Specifications**

Material : ABS  
Dimensions (LxWxH) : 170x60x9mm

**MULTIFUNCTIONAL 12V  
SOCKET**



**Code** WS4100630

**Technical Specifications**

12V + ant. + sat.  
12V DC, max. 6A  
Dimensions (LxWxH): 53x53x45,5mm

**13 PIN PLUG**

**NEW**



**Code** HB4701500

PVC, 48x58x96mm

**13 PIN SOCKET**

**NEW**



**Code** HB4701410

PVC, 63x76x71mm

**CONSUMER UNIT 2-MODULE**

**NEW**



**Code** HB4601603

Fuse box with 10A  
Double-pole circuit breaker 10A

**CONSUMER UNIT 4-MODULE**

**NEW**



**Code** HB4601513

Fuse box with RCD and circuit breaker  
10A and 16A  
240x91x150mm

**CONSUMER UNIT 6-MODULE**

**NEW**



**Code** HB4601723

Fuse box with RCD and circuit breaker  
10A and 16A  
240x91x150mm

**LANCIANO RAIL**

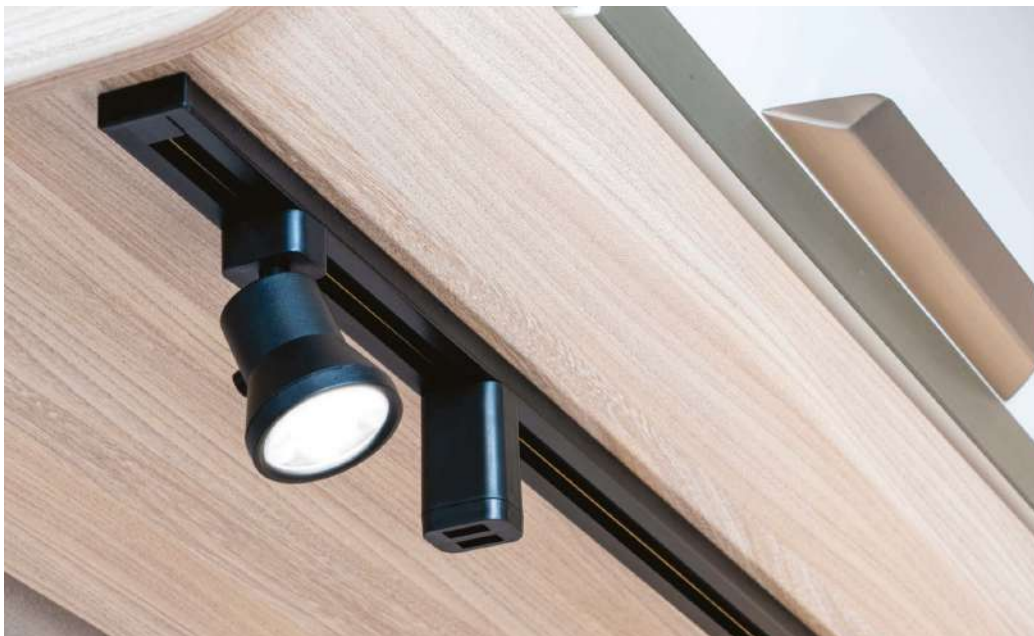

**Code** WS4305749A3

**Technical Specifications**

Voltage	: 12V DC
Polarity sensitive	: Yes
Degree of protection	: IP 21
Connection wire length	: 200 + 5 stripped mm
Dimensions (LxWxH)	: 1000x10x25mm
Net weight	: 200gr
Rail length	: 1000mm
Mounting hole diameter	: Ø4mm
Material	: Plastic
Color	: Black



**LANCIANO RAILSISTEM SMALL SPOT**

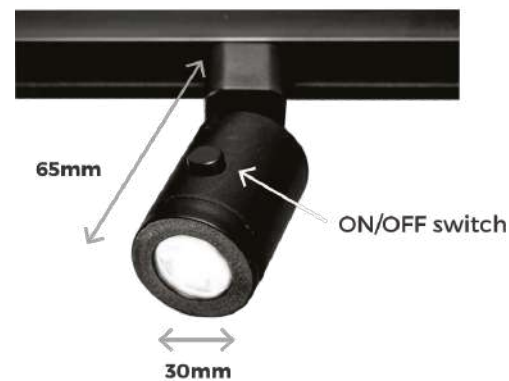

**Code** WS4305749C

**Technical Specifications**

Voltage	: 12V DC
Power consumption	: 0,9W
Brightness in lumen	: 100Lm
Light colour	: 4000K
Energy class	: A++
Material	: Plastic
External dimmable	: Yes
Switch type	: Push switch
Color	: Black

**VERONA FLEX SILICONE SPOT DIM-TOUCH SWITCH**



**Code** WS4306910

**Technical Specifications**

Voltage	: 12V DC
Power consumption	: 2W
Lumen	: 150Lm
Light colour	: 4000K
Energy class	: A+
Material	: Metal/Polycarbonate
Stabilize	: Yes
Switch	: Dim-touch switch
Beam angle	: 170°
Flexible arm	: 250mm
Color	: Black, white
USB connection	: 2 piece
Max. current	: 1x 2A, 1x 1A

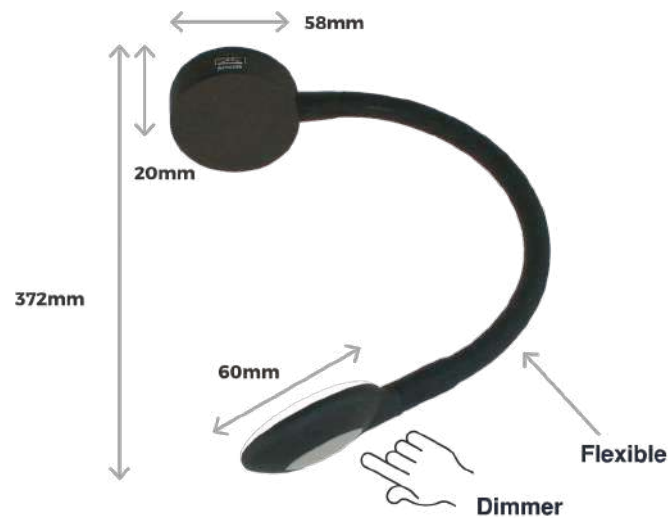

**LANCIANO DOUBLE USB SOCKET**

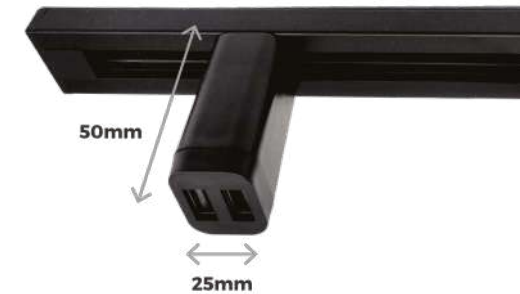

**430579C**

**Code** WS4305749B

**Technical Specifications**

Input voltage	: 12V DC
USB connection	: 2 piece
USB type	: USB-A
Max. current	: 3.0A
Polarity sensitive	: Yes
Dimensions	: 49x26x20mm
Material	: Plastic
Color	: Black

**ARSIE SURFACE SPOT LOW BASE WITH TOUCH SWITCH**

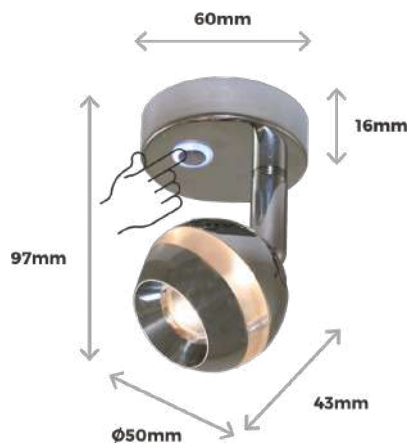

**Code** WS4308010

**Technical Specifications**

Voltage : 12V DC  
 Power consumption : 3W  
 Lumen : 175Lm  
 Light colour : 3200K  
 Energy class : A++  
 Material : Metal  
 Stabilize : Yes  
 Switch : Touch switch  
 Beam angle : 120°

**ARSIE SURFACE SPOT WITH TOUCH SWITCH**

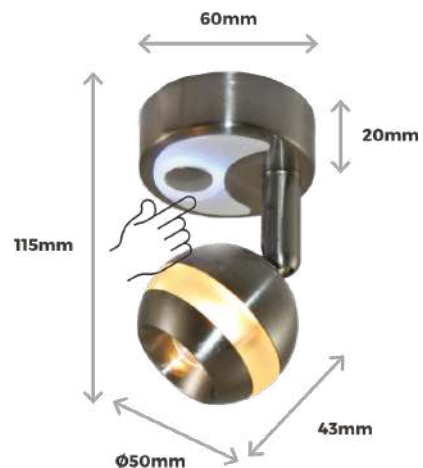

**Code** WS4306004W

**Technical Specifications**

Voltage : 12V DC  
 Power consumption : 3W  
 Lumen : 160Lm  
 Light colour : 4000K  
 Energy class : A+  
 Material : Metal  
 Stabilize : Yes  
 Switch : Touch switch  
 Beam angle : 120°

**TRITON - CEILING LIGHT**

**NEW**



**Code** WS4305739L

**Technical Specifications**

Voltage : 10-30V DC  
 Power consumption : 1,4 W  
 Lumen : 150Lm  
 Light colour : 4000K  
 Energy class : A++  
 Material : Metal  
 Switch : Basic Switch  
 Beam angle : 80°

**COPIANO CEILING LIGHT**

**NEW**



**Code** WS4305744L

**Technical Specifications**

Voltage : 10-30V DC  
 Power consumption : 1,4 W  
 Lumen : 150Lm  
 Light colour : 3000K/4000K  
 Energy class : A++  
 Material : Metal/Frosted glass  
 Switch : Basic Switch  
 Beam angle : 100°

**JESPER - CEILING LIGHT**

**NEW**



**Code** HBJ600100

**Technical Specifications**

Color : Mat chrome  
 Material : Metal  
 Angle : 160°  
 Diameter : 24cm  
 Energy : 12V DC  
 Connection : MR16  
 Power consumption : 3x3 Watt  
 Energy class : +  
 Light colour : 3000k  
 Lumen : 690

**TIVOLI - CEILING LIGHT**

**NEW**

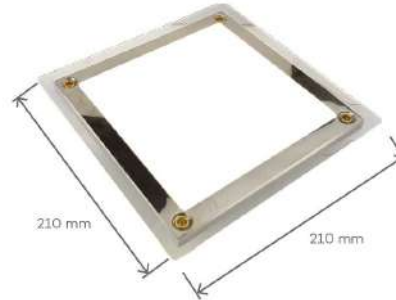

**Code** HB4305800

**Technical Specifications**

Voltage : 12V DC  
 Power consumption : 10W  
 Lumen : 500Lm  
 Light colour : 4000K

Create a good light source at the sitting area and in the bedroom.

**Design of the Tivoli**

The Tivoli is a modern square ceiling light. The very flat model is made of PMMA plastic, so it is also lightweight. PMMA looks like glass, giving it a transparent look.

**Illuminate**

The light is evenly distributed in the ceiling light, which means there are no harsh shadows and there is a strong light emission over the entire surface. The light intensity of the Tivoli can be adjusted with an external LED dimmer.

**Small but strong**

The ceiling light is small in size, with a length and width of 21x21cm and a very slim height of 1.3cm. The maximum light intensity, however, is very high, namely 500 lumens.

**Mounting**

The Tivoli can be installed surface mounted or recessed. The ceiling light is easy to install in the desired location. Mount the lamp with 4 screws in the 4 screw holes (Ø6.5 mm). After installation, you can finish off the lamp by covering the screw holes with the chrome coloured caps supplied and the lamp is ready for use.

**CHROME CEILING LIGHTING**



**Code** WS4305825

**Technical Specifications**

Voltage : 12V-24VDC  
 Power consumption : 5W  
 Lumen : 400Lm  
 Light colour : 4000K  
 Energy class : A  
 Material : Metal  
 Stabilize : Yes  
 Beam angle : 180°  
 Diameter : Ø165mm

**ALTINO CEILING LIGHT WITH IR SENSOR**

**NEW**



**Code** WS4305810

**Technical Specifications**

Voltage : 12V DC  
 Power consumption : 5W  
 Brightness in lumen : 270lm  
 Light colour : 4000K  
 Material : Metal + plastic  
 Dimmable : Yes  
 Switch type : IR sensor  
 Colour : Brushed nickel

**CASOLI CEILING LIGHT WITH IR SENSOR**

**NEW**



**Code** WS4305812

**Technical Specifications**

Voltage : 12V DC  
 Power consumption : 4W  
 Brightness in lumen : 200lm  
 Light colour : 4000K  
 Material : Metal + plastic  
 Dimmable : Yes  
 Switch type : IR sensor  
 Colour : Brushed nickel

**SALETTI SURFACE SPOT**

**NEW**



**Code** WS4305815

**Technical Specifications**

Voltage : 12V DC  
 Power consumption : 2.8W  
 Brightness in lumen : 120lm  
 Light colour : 3000K  
 Material : Metal  
 Dimmable : Yes Switch type  
 Without switch  
 Colour : Brushed nickel

**BONO - SURFACE SPOT WITH ON/OFF SWITCH**

**NEW**



**Code** WS4300175

**Technical Specifications**

Voltage : 12V DC  
 Power consumption : 1.3W  
 Brightness in lumen : 100lm  
 Light colour : 4000K  
 Material : PC  
 Dimmable : Yes Switch type  
 Push switch  
 Colour : Chrome  
 On/Off Switch : Blue light

**OBERON SURFACE RAIL SPOT**

**NEW**



**Code** WS4305741RBL

**Technical Specifications**

Voltage : 10-30V DC  
 Power consumption : 1.4W  
 Brightness in lumen : 150lm  
 Light colour : 3200K  
 Material : Metal  
 Dimmable : No  
 Switch type : Basic switch  
 Colour : Brushed steel

**RAIL FOR SPOTS (1600 MM)**

**NEW**



**Code** WS4305748C  
1600 mm

**Code** WS4305748B  
800 mm

**Technical Specifications**

Voltage : 10-30V DC  
 Cable : 1000mm  
 Rail length : 1600mm  
 Mounting hole diameter: Ø4mm

\*Excluding surface rail spot

**GABY CABINET LIGHT WITH SENSOR**

**NEW**



**Code** WS4302019

**Technical Specifications**

Voltage : 12V DC  
 Power consumption : 1W  
 Brightness in lumen : 50lm  
 Light colour : 4000K  
 Material : Aluminium/PC  
 Dimmable : No  
 Switch type : Sensor  
 Colour : Silver

**PORZIO - DOOR LIGHT**

**NEW**



**Code** WS4302560

**Technical Specifications**

Voltage : 12V DC  
 Power consumption : 4.5W  
 Brightness in lumen : 150lm  
 Light colour : 4000K  
 Material : ABS  
 Dimmable : Yes  
 Switch type : Without switch  
 Colour : White



**MODEL 3000 - DOOR AND AWNING LIGHT**



<b>Code</b>	WS4302590 / White
<b>Code</b>	WS4302580 / Grey

**Technical Specifications**

Voltage	: 12V DC
Power consumption	: 5,5 W
Lumen	: 250Lm
Light colour	: 5000K
LED	: 48
Energy class	: A
Material	: ABS
Dimmable	: Yes
Beam angle	: 110°

**VIGANELLA 135 - DOOR LAMP AND RAIN GUTTER**



<b>Code</b>	WS4302530
-------------	-----------

The Viganella awning light, with its high brightness, is specially designed for lighting up the entrance of camper vans from type Fiat Ducato, Peugeot Boxer, Citroën Jumper, Renault Master, Opel Movano and Nissan NV400. The Viganella awning light has a double function as it also functions as a rain gutter. It keeps the rain from getting in through the sliding doors and when the doors are open it transports the rain from the roof to the sides of the opened doors.

**Technical Specifications**

Voltage	: 12V DC
Power consumption	: 7W
Lumen	: 450Lm
Light colour	: 4000K
LED	: 86
Energy class	: A
Material	: Aluminium
Dimmable	: Yes
Beam angle	: 130°
Color	: Black

**VIGANELLA 180 - DOOR LAMP AND RAIN GUTTER**



<b>Code</b>	WS4302529
-------------	-----------

The Viganella lamp is a door light with high luminosity to illuminate the entrance to the camper. The door light is suitable for installation on the camper Westfalia MAN, Volkswagen Crafter and Mercedes Sprinter.

**Sliding door**

The lamp fits exactly in the opening of the wider sliding doors of these motorhomes, illuminating the entrance over the entire width.

**Light brightness**

The door light has a high brightness. The frosted cover distributes the light evenly, avoiding harsh shadows. This is great for getting in and out of the vehicle, but also when sitting in front of the motorhome. With an external dimmer, the light intensity of the lamp can be dimmed.

**Technical Specifications**

Voltage	: 12V DC
Power consumption	: 7W
Lumen	: 450Lm
Light colour	: 4000K
LED	: 86
Energy class	: A
Material	: Aluminium
Dimmable	: Yes
Beam angle	: 130°
Color	: Black

## CAMPING AND CARAVAN ACCESSORIES

Camping and caravan accessories provide you with freedom and comfort on the road.





**THULE TEPUI EXPLORER AYER**



**Code** TH901200

- Can accommodate up to two people.
- Panoramic skylights and windows allow you to starGase, get closer to nature, and keep the tent cool and well ventilated.
- Exterior attachment points for lamps, storage solutions, or other gear to make a cozy, more personalized camp.
- Constructed from coated 600 denier and a 260g poly-cotton blend made to withstand the elements of any season.
- Weather-resistant and durable main tent fabric withstands harsh weather conditions and is breathable to reduce condensation build-up inside the tent.
- Mesh panels offer plenty of ventilation and open for more airflow.
- Large internal pockets for storing gear and camping accessories.
- Includes a 2.5 in / 6 cm high-density foam mattress for added comfort.

**Technical Specifications**

Capacity : 2 people  
 Dimensions (WxHxD) : 2140x990x1220mm  
 Weight : 45,5 kg  
 Color : Haze Gray  
 Maximum load capacity : 182 kg

**THULE TEPUI KUKENAM**



**Code** TH901300

- Can accommodate up to three people.
- Panoramic skylights and windows allow you to starGase, get closer to nature, and keep the tent cool and well ventilated.
- Exterior attachment points for lamps, storage solutions, or other gear to make a cozy, more personalized camp.
- Constructed from coated 600 denier and a 260g poly-cotton blend made to withstand the elements of any season.
- Weather-resistant and durable main tent fabric withstands harsh weather conditions and is breathable to reduce condensation build-up inside the tent.
- Mesh panels offer plenty of ventilation and open for more airflow.
- Large internal pockets for storing gear and camping accessories.
- Includes a 2.5 in / 6 cm high-density foam mattress for added comfort.

**Technical Specifications**

Capacity : 3 people  
 Dimensions (WxHxD) : 2440x1320x1430 mm  
 Weight : 54 kg  
 Color : Haze Gray  
 Maximum load capacity : 272 kg

**THULE TEPUI AUTANA**



**Code** TH901400

- Can accommodate up to three people.
- Panoramic skylights and windows allow you to starGase, get closer to nature, and keep the tent cool and well ventilated.
- Exterior attachment points for lamps, storage solutions, or other gear to make a cozy, more personalized camp.
- Constructed from coated 600 denier and a 260g poly-cotton blend made to withstand the elements of any season.
- Weather-resistant and durable main tent fabric withstands harsh weather conditions and is breathable to reduce condensation build-up inside the tent.
- Mesh panels offer plenty of ventilation and open for more airflow.
- Large internal pockets for storing gear and camping accessories.
- Includes a 2.5 in / 6 cm high-density foam mattress for added comfort.

**Technical Specifications**

Capacity : 3 people  
 Dimensions (WxHxD) : 3100x1320x1430 mm  
 Weight : 69,5 kg  
 Color : Haze Gray  
 Maximum load capacity : 272 kg

**THULE TEPUI EXPLORER AUTANA**



**Code** TH901500

- Can accommodate up to four people.
- Panoramic skylights and windows allow you to starGase, get closer to nature, and keep the tent cool and well ventilated.
- Exterior attachment points for lamps, storage solutions, or other gear to make a cozy, more personalized camp.
- Constructed from coated 600 denier and a 260g poly-cotton blend made to withstand the elements of any season.
- Weather-resistant and durable main tent fabric withstands harsh weather conditions and is breathable to reduce condensation build-up inside the tent.
- Mesh panels offer plenty of ventilation and open for more airflow.
- Large internal pockets for storing gear and camping accessories.
- Includes a 2.5 in / 6 cm high-density foam mattress for added comfort.

**Technical Specifications**

Capacity : 4 people  
 Dimensions (WxHxD) : 3100x1320x1830 mm  
 Weight : 81,5 kg  
 Color : Haze Gray  
 Maximum load capacity : 295 kg



## THULE APPROACH S

**NEW**



**Code** TH901010

- Can accommodate up to two people.
- Panoramic skylights and windows allow you to starGaze, get closer to nature, and keep the tent cool and well ventilated.
- Exterior attachment points for lamps, storage solutions, or other gear to make a cozy, more personalized camp.
- Constructed from coated 600 denier and a 260g poly-cotton blend made to withstand the elements of any season.
- Weather-resistant and durable main tent fabric withstands harsh weather conditions and is breathable to reduce condensation build-up inside the tent.
- Mesh panels offer plenty of ventilation and open for more airflow.
- Large internal pockets for storing gear and camping accessories.
- Includes a 2.5 in / 6 cm high-density foam mattress for added comfort.

### Technical Specifications

Capacity : 2 people  
 Dimensions (WxHxD) : 1230x890x2130 mm  
 Weight : 50 kg  
 Color : Pelican gray  
 Max. Load Capacity : 300 kg

## THULE APPROACH M

**NEW**



**Code** TH901012

- Can accommodate up to three people.
- Panoramic skylights and windows allow you to starGaze, get closer to nature, and keep the tent cool and well ventilated.
- Exterior attachment points for lamps, storage solutions, or other gear to make a cozy, more personalized camp.
- Constructed from coated 600 denier and a 260g poly-cotton blend made to withstand the elements of any season.
- Weather-resistant and durable main tent fabric withstands harsh weather conditions and is breathable to reduce condensation build-up inside the tent.
- Mesh panels offer plenty of ventilation and open for more airflow.
- Large internal pockets for storing gear and camping accessories.
- Includes a 2.5 in / 6 cm high-density foam mattress for added comfort.

### Technical Specifications

Capacity : 3 people  
 Dimensions (WxHxD) : 1430x1020x2400 mm  
 Weight : 58 kg  
 Color : Pelican gray  
 Max. Load Capacity : 300 kg

## THULE APPROACH L

**NEW**



**Code** TH901015

- Can accommodate up to three people.
- Panoramic skylights and windows allow you to starGaze, get closer to nature, and keep the tent cool and well ventilated.
- Exterior attachment points for lamps, storage solutions, or other gear to make a cozy, more personalized camp.
- Constructed from coated 600 denier and a 260g poly-cotton blend made to withstand the elements of any season.
- Weather-resistant and durable main tent fabric withstands harsh weather conditions and is breathable to reduce condensation build-up inside the tent.
- Mesh panels offer plenty of ventilation and open for more airflow.
- Large internal pockets for storing gear and camping accessories.
- Includes a 2.5 in / 6 cm high-density foam mattress for added comfort.

### Technical Specifications

Capacity : 4 people  
 Dimensions (WxHxD) : 1830x1020x2440 mm  
 Weight : 68 kg  
 Color : Pelican gray  
 Max. Load Capacity : 300 kg

**THULE FOOTHILL**

**NEW**



**Code** TH901250

- Folds compactly to preserve valuable space on your roof for bikes, kayaks, and other cargo
- Aerodynamic profile when driving provides a smaller footprint to store in the off-season
- Despite a compact travel size, the interior is just as spacious as a traditional 2-person rooftop tent
- Features a wide entry, oversized panoramic rear window and dual skylights for maximum airflow and enhanced stargazing
- Telescopic internal frame poles allow for easy, one-person setup and breakdown
- Low-profile, symmetrical design allows the tent to be mounted on either side of your vehicle
- Includes a plush, low profile 4cm foam mattress with removable, machine-washable cover
- Exterior attachment points for lamps, storage solutions, or other gear to make a cozy, more personalized camp
- Weather-resistant and durable main tent fabric withstands harsh weather conditions and is breathable to reduce condensation build-up inside the tent
- The tent's internal pockets provide extra space to store items

**Technical Specifications**

Capacity : 2 people  
 Dimensions (WxHxD): 1190x930x2130 mm  
 Weight : 55,5 kg  
 Color : Green  
 Max. Load Capacity : 300 Kg

**THULE BASIN**

**NEW**



**Code** TH901017

- Quick setup - from closed to ready for use in less than a minute
- Pops straight up to provide a spacious living area
- Versatile design converts rooftop tent for up to two people into a spacious cargo carrier
- Patented canopy zipper system allows for easy conversion between a tent and a cargo carrier
- Release both ends to open as a rooftop tent or, when converted to a cargo carrier, open one side to easily access gear
- Easy to install mounting brackets securely lock the tent to your vehicle, feature a torque limiter to always ensure a safe install, and take half the time to install compared to traditional mounting systems
- Insulated roof to help control the temperature inside the tent and reduce noise
- Weather resistant, durable and breathable canopy for extra protection and comfort
- Includes a telescoping ladder that attaches to either side for easy access
- Includes a foam mattress with removable cover for added comfort

**Technical Specifications**

Capacity : 2 people  
 Dimensions (WxHxD): 1400x1090x2140 mm  
 Weight : 80 Kg  
 Color : Green/Black  
 Max. Load Capacity : 300 Kg

**THULE BASIN WEDGE**

**NEW**



**Code** TH901018

- Quick setup - from closed to ready for use in less than a minute
- Wedge shape makes it our most stable and quickest rooftop tent to deploy
- Versatile design converts rooftop tent for up to two people into a spacious cargo carrier
- Patented canopy zipper system allows for easy conversion between a tent and a cargo carrier
- Easy to install mounting brackets securely lock the tent to your vehicle, feature a torque limiter to always ensure a safe install and take half the time to install compared to traditional mounting systems
- Insulated roof to help control the temperature inside the tent and reduce noise
- Weather resistant, durable and breathable canopy for extra protection and comfort
- Includes a telescoping ladder that attaches to either side or the rear of the tent for easy access
- Includes a foam mattress with removable cover for added comfort

**Technical Specifications**

Capacity : 2 people  
 Dimensions (WxHxD): 1400x1320x2130 mm  
 Weight : 71 Kg  
 Color : Green/Black  
 Max. Load Capacity : 300 Kg

## MOBILE SHOWER 12V/24V



<b>Code</b>	CM8620.01.10_20 12V
<b>Code</b>	CM8630.05.10_20 24V

12 volt portable shower

- 12 L/min with submersible pump.  
Pressure 0.6 bar, consumption 18-24W
- shower head, pushable, constant flow of water or pulser.
- 2 m shower hose
- Winding cable approximately 4m and 12 volt plug.
- 20 L folding jelly can be 290x290x320 mm in size.  
Packaged in a handy plastic box.  
Dimensions: 320x280x119 mm

## SOLAR SHOWER



**Code** HB2402450

20 litres

### Technical Specifications

Color	: Black
Net Weight	: 0.260kg
Product length	: 59cm
Product width	: 40cm
Filling weight	: 20.16kg
Maximum temperature:	41°C

## GRAB HANDLE

mpk



- It can be used as an outdoor steering arm of caravans.
- Cover and body can be selected separately.
- Extra strong
- Screws are not visible

Color	Cover	Base	Weight
Slate grey - RAL 7015	MP5300SG	MP5301SG	29/65 gr
Signal white - RAL 9003	MP5300SW	MP5301SW	29/65 gr



## THULE LEVELERS



### The stable way to park

#### Top stability

Thule levelers offer a very large surface area for increased stability, making them ideal for wider tyres, with a maximum load capacity of 5 ton/set.

#### Striped area

The three heights make it easier to get your vehicle leveled. The striped area offers perfect grip between the tyre and the leveler.

#### Features

- 3 Height: 44 - 78 - 112 mm
- Dimensions (WxHxD) : 560x150x200mm
- Weight: 1.8 kg per leveler

Code TH307617



#### Included

- Set of 2 levelers
- Storage bag

## STORAGE AND ORGANIZERS



Space is always too tight, therefore a flexible storage is crucial. It allows you to have a place for each item and easy access to it. With our smart storage solutions you can store your things inside or outside your van to fully enjoy your free time.

#### Fixing systems

- Different systems allow easy use of pockets inside or outside your vehicle
- Quick and easy installation

#### Storage and organizers

- Provides easy access to your belongings with many different storage compartments.
- Made of durable and strong material.
- It is ergonomic and can be folded when not in use.



#### Roof Boxes

- Roof or rear mounted
- Sturdy and durable material
- Different mounting options

**THULE WALL ORGANIZER**



**Code** TH306924

Provides storage space for all kinds of things.

**Features**

- 14 pockets in 2 different sizes
- Integrated cover with zipper to protect your items during transport
- Dimensions LxH: 50x85 cm

**Fixation** (not included)

- Thule Strap Kit for Organizers
- Thule POD 2.0
- Thule POD 1.0

**AYAKKABI ORGANİZATÖRÜ**



**Code** TH306925

Provides storage space for at least 10 pairs of shoes.

**Features**

- 10 large and 2 mesh pockets
- Integrated cover with zipper to protect your shoes during transport
- Dimensions LxH: 50x80 cm

**Fixation** (not included)

- Thule Strap Kit for Organizers
- Thule POD 2.0
- Thule POD 1.0

**TEZGAH DÜZENLEYİCİSİ**



**Code** TH306926

Keeps all essential items within reach.

**Features**

- Different compartments and elastic loops
- Integrated paper towel holder
- Dimensions LxH: 90x40 cm

**Fixation** (not included)

- Thule Strap Kit for Organizers
- Thule POD 2.0
- Thule POD 1.0

**TUVALET TAKIMI**



**Code** TH306928

**Features**

- 13 separate compartments
- Easy to carry thanks to the handle on top
- Removable mirror
- Dimensions closed LxH: 35x40 cm
- Dimensions opened LxH: 35x120 cm
- L-shaped hook to fit over doors

**Fixation** (not included)

- Thule POD 2.0
- Thule POD 1.0

**THULE GO BOX**

Handy and foldable storage box in two sizes



<b>Code</b>	M-TH306929 Orta boy
<b>Code</b>	L-TH306930 Büyük boy

Handy and foldable storage box in two sizes.

**Features**

- 2 main compartments, 3 side pockets
- Simple to carry and it folds up quickly to store when not in use
- Foldable cap for rain protection
- Dimensions Medium LxWxH: 61x36x30 cm
- Dimensions Large LxWxH: 61x46x30 cm

**THULE LADDER FIXATION KIT**

Provides storage space for each product.



<b>Code</b>	TH301405
-------------	----------

**Features**

- Max. load: 10 kg
- Dimensions LxWxH: 66x10x8 cm
- Weight: 1.2 kg

**THULE STRAP KIT FOR ORGANIZERS**



<b>Code</b>	TH307124
-------------	----------

**Features**

- Fits in an optional rail or in the front lead rail of the awning
- Maximum load: 10 kg/strap
- Quick release system
- Adjustable in height
- Strap length: 1.20 m
- Set of 2 pieces

**THULE POD 2.0**



<b>Code</b>	TH306804
-------------	----------

**Features**

- Mounted with two screws and/or glue
- Cover included
- Compact and discrete design
- Maximum load: 10 kg/POD
- Dimensions LxWxH: 5.5 x 1.2 x 3 cm
- Set of 2 pieces

**THULE BACKSPACE XT**

Rear-mounted Cargo

300  
L



**Code** TH938300



**Features**

- Load capacity: 50 kg
- Volume: 300L
- Weight: 8.6 kg
- Dimensions (WxHxD) : 1370x680x465mm

Lightweight, durable cargo box that fits onto the Thule VeloSpace XT bike rack, keeping all of your gear easily accessible.

**Mounting**

On a Thule VeloSpace XT bike rack

- 595000 - Thule Load Net 80 x 80 cm
- 595100 - Thule Load Net 130 x 90 cm
- 859101 - Thule Canyon Extension XT

**THULE CANYON XT**

Ideal for carrying loads of all shapes and sizes, this model is a roof basket with a sturdy, stylish and lightweight steel pipe design.



**Code** TH859002

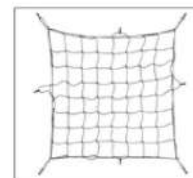

**Features**

- Load capacity: 65 kg
- Weight: 12.3 kg
- Dimensions (WxHxD) : 1040x150x1270mm
- Extension Dimensions (WxHxD): 1040x150x1780mm

**Aksesuarlar**

- 595000 - Thule Load Net 80x80 cm
- 595100 - Thule Load Net 130x90 cm
- 859101 - Thule Canyon Extension XT

**Features**

- Wind fairing is included to help airflow over your cargo
- Stylish and functional low-profile design, with tapered side walls for easier loading and unloading
- Lockable with the Thule One-Key System
- Make the cargo area 51 cm longer by adding the Thule Canyon Extension XT

**12V COFFEEMAKER WITH POT**

**NEW**



**Code** HB7702500

Coffee machine with pot working with 12V  
 • Power consumption 170 Watt

**12V KETTLE**

**NEW**



**Code** HB7702600

183x185 cm sized, 12 Volt powered, 1 liter capacity kettle. 150W power and 542 grams.

**HEAVY-DUTY STEP STOOL - SPOT**

**NEW**



**Code** LP2021104024

- Commonly used in caravans
- Tough plastic construction
- Grated top surface keeps step clear of debris
- Available in three sizes to fit your needs
- Colors customizable on request according to quantities

**Features**

Dimensions (WxHxD): 410x220x260mm  
 Weight: 1 kg  
 Load Capacity: 150 kg

**STEEL STEP**

**NEW**



**Code** HB7401050

390x430x262 mm  
 Max. 150kg

**3-IN-1 TV SUPPORT SOLUTION**

**NEW**



**Code** HB4507100

TV support with mounting plate The support can be folded in and secured during driving. Through smart design, the TV support can be used in 3 different lengths. Max. 15kg Suitable for display size: 15" - 27" VESA Standard: 75 and 100 with complete mounting set: mounting backplate, bolts in 3 sizes, integrated waterleveller, fixing screws for television.

**Technical Specifications**

Max : 15kg  
 Suitable for display size: 15" - 27"  
 Weight : 1,75 kg  
 VESA standard : 75 and 100  
 With complete mounting set: Mounting backplate, bolts in 3 sizes, intergrated water leveller, fi xing screws for television.

**TORINO - TRASH BIN**

**NEW**



**Code** HB7702500

8 liter 270x300x160mm (wxhxd) heavy duty trash bin with 2 different types of mounting systems for caravan and awning

### RECHARGEABLE HAND SHOWER SET

**NEW**



**Code** HB2402410

When you want to quickly rinse off and don't have a shower to your disposal, you can consider this compact hand shower with battery.

The great advantage of this hand shower is that you don't need any power supply connection, as it has its own battery. You can easily take it with you in a backpack when you go for a hike.

Put the pump into a bucket of water or maybe into a lake, turn it on and have a nice shower. With the included hook you can also hang the shower on a tentpole or stick it on a flat surface with the suction cup.

#### Technical Specifications

Voltage : 3.7V DC  
 Current : 2.5A  
 Battery capacity : 2200mAh (lithium)  
 Shower time : 50 minutes  
 Recharging time : 3.5-4 hours  
 Hose length shower - pump: 1.8m  
 Wire length pump - battery pack: 0.75m  
 Charging cable length: 0.8m  
 Material : plastic  
 Net weight : 550g

### ALL-IN-1 WATER CONNECTION SET

**NEW**



**Code** HB2402410

Water connection set includes; sprayer, tap adapter 3-4 / 1-2tap adapter small, tap adapter largehose connector with water stop, hose connector without water stopideal solution for the diverse taps on campings through Europe.

Color : Yellow (Photo is representative)  
 Weight : 0.30g  
 Material : Plastic

### WASTE WATER HOSE AND ADAPTER SET

**NEW**



**Code** HB2400840H

Through the extendable waste waterhose, which can be extended and bended up to 1.10m, the waste water can be emptied into the sewer or in the waste watertank. If extra length is needed, then two or more extendable waste waterhoses can be easily connected.

Dimensions  
 Unextended : 483x045mm  
 Extended : 1090x045mm

The universal adaptor (art. 2400860) is used to connect the drain (hose) (among other of your sink) with the waste waterhose, when the drain (hose) doesn't directly fit onto the waste waterhose.The universal adaptor can then easily be connected to the extendable waste waterhose.

**SIENA - DOOR LATCH**

**NEW**



**Code** HB7601710H

The solution for rattling caravan and motorhome doors!

**Product description of the door catch**

You are sitting outside enjoying the sun, but you hear the door of your motorhome or caravan rattling behind you. The door catch is the solution!

With the door catch, you lock the door in a fixed position, so that the door stays open.

**Installing the door catch**

The door catch is easy to install on the outside of your caravan or motorhome. The plastic parts both feature 2 mounting holes. These mounting holes are meant for screwing the parts onto the caravan or motorhome. 1 part is mounted into the wall, the other part onto the door. The door catch can be used immediately after installation.

Distance between mounting holes on the wall: 40 mm  
Distance between mounting holes on the door: 60 mm

**Material of the door catch**

The door catch features a click system. Lock the door with 1 click.

The material is plastic. The dimensions of the door catch are 70 X 40 x 30 mm. The colour is white.

**TOLEDO - THERMIC WINDSHIELD COVER**

**NEW**



**Code** HB7601228

Keep the temperature in the motorhome under control!

The Toledo thermic windscreen cover can be used both in the summer and winter. In the summer, it keeps the motorhome nice and cool. And in winter, it keeps the cold out.

**Multifunctional**

The window insulation is a thermal insulation. It ensures the thermal protection of the motorhome. The windscreen can be used both against heat/UV radiation in the summer and against cold and freezing windows in the winter.

Besides insulation, it also keeps the windows of your motorhome clean. When you want to travel to your next destination, you don't need to clean the windows first.

The window insulation is suitable for Fiat Ducato, Peugeot Boxer and Citroën Jumper vans from 2002 to 2021.

**The thermic windscreen cover is complete**

The insulation screen comes with mounting materials, consisting of 5 elastic cords with hooks. The 2 flexible elastic bands are part of the screen cover.

A handy storage bag is also included. The outdoor insulation is easy to roll up and store in the bag.

**Technical specifications**

Suitable for all models of Fiat Ducato, Peugeot Boxer and Citroën Jumper vans from 2002 till 2021. Fasten on the van chassis with 7 Holes + 7 Elastic cords with hooks, Fasten on the van doors with 2 flexible cords.  
Material thickness 3,5mm,  
EVA foam with aluminium foil  
3550x1507mm, 1440g

**CARAVAN MIRROR**

**NEW**



**Code** HB7100090

**Features**

152x110mm

**CONVEX CARAVAN MIRROR**

**NEW**



**Code** HB7100800

**Features**

181x135mm

### CARAJACK - ALUMINIUM SUPPORTS

**NEW**



**Code** HB7401100

It is very important to ensure the balance of your vehicle when you will stay in one place for a longer time. Therefore, use Carajack aluminum axle supports.

1 piece can carry 1000kg weight.

#### Technical specifications

Height adjustable 300mm-430mm,  
1 piece = Max. 1000kg  
150x150x300mm

### CABLE ENTRY COVER

**NEW**



**Code** HB4601524

### JACKHANDLE (19MM)

**NEW**



**Code** HB7207030

85 cm uzunluğa sahip krikö

### 12V EMBEDDED WIRELESS CHARGER

**NEW**



**Code** HB4700860H

Wow! Integrate your mobile phone charger into the interior of your caravan or motorhome!

This induction charger makes it possible to charge your mobile phone wirelessly. No more hassle with cords. What's more, you can neatly conceal the wireless charger in the interior. The induction charger is perfect for use in your favourite sitting area in the caravan or motorhome.

This wireless charger is specifically designed for use in the caravan and motorhome. Installing the wireless charger takes a bit of work, but you get something great in return!

The induction charger can be installed by sawing/drilling a hole with a 60 mm diameter. You then connect the wiring to the 12V DC power network and place the induction charger into the hole you just made. The wiring is at the bottom of the charger, which means you can conceal it neatly. The induction charger clamps itself through the ribs on the outside of the circle.

The wireless charger has an accessible and sleek design. Its beautiful design makes it very suitable to integrate into any interior. The black colour gives it an extra fashionable appearance.

The charger is about as wide as a 'regular' smartphone, so you can easily put your mobile phone in the right place. The nice thing is that your phone doesn't need to be placed on the induction charger very precisely. When your mobile phone is charging, the induction charger emits a blue light. If the blue light turns off, that means your mobile phone is charged to 100%. The dimensions of the wireless charger are 78x78x 9.5 mm. The weight is 50 grams. The induction charger only protrudes 2.5 mm above the surface.



## FURRION VISION S® RV BACKUP CAMERA SYSTEM WITH 7" MONITOR



Code LP2022447305

Safely back into parking spaces while having a wide view of your surroundings with the Furrion Vision S RV backup camera system #FOS07TASF. This configurable system acts as a security camera as well as giving you peace of mind while on and off the road.

### Quick Facts:

- Reliable digital connection (2.4GHz)
- 720 x 480 high-resolution camera system
- Wide viewing angle with up to four cameras displayed
- Night vision and intelligent infrared cut filter for clear viewing
- Motion detection and microphone for security area monitoring
- Security camera auto-wake with motion detection
- IP65 waterproof-rated camera technology for durability
- Large, 7" HD monitor with anti-glare display
- Wireless camera system is easy to set up
- Rear assist marker lines to align your vehicle
- Furrion Reference Number: FOS07TASF

### Reduce Blind Spots While Driving

Experience up to four different camera angles at once on the high-resolution monitor for maximum visibility around your RV. With a wide viewing angle, Furrion Vision S gives you visibility all around your RV to reduce blind spots and make reversing easier and safer. Rear assist marker lines help you back up safely with coverage right down to the bumper, making it easy to see blind spots and hidden obstacles when backing up.

### See Clearly, Even at Night

The high-res camera technology allows for a clear, clean infrared view during nighttime use. This serves an additional safety feature for the camera system to be used as a motion-activated security camera with auto-wake to keep your family safe while asleep in your camper. The built-in microphone also ensures an extra layer of safety. When used with an SD card, you can review videos at your leisure.

### Multiple Mounting Options

The low-profile design of the Vision S promotes an unobstructed view out your windshield. The monitor can be mounted on your windshield at a variety of angles, using the included suction cup bracket. An interior table stand is also available, as well as a wall-mount option (sold separately). The high-resolution monitor allows you to toggle between cameras, and you can view up to four different camera angles at once to make passing, tailgating and merging cars are much easier to see (extra cameras sold separately).

### Vision S RV Camera System Features:

**QUICK & EASY INSTALLATION** - Most RVs are already prepped for the Vision S camera system, eliminating extensive drilling requirements. Installation is also quick and straightforward for non-prepped units

**WATERPROOF CAMERA WITH NIGHT VISION** - This kit comes with high-resolution (720 x 480), IP65 waterproof camera technology with infrared night vision, live streaming, intelligent IR cut filters and a wide viewing angle

**STABLE & LONG-RANGE SIGNAL STRENGTH** - Wireless communication provides a reliable digital connection with no lag between camera and monitor. This system is tested for up to 100 feet at high speeds and extended range of up to 492 feet in open spaces

**CLEAR & EASY VIEWING** - The anti-glare monitor comes with park assist marker lines and displays a clear image for up to four cameras for all-around coverage.

The included windshield mount allows for customizable viewing angles to suit your needs

**SECURITY & SAFETY** - The camera system can serve as a security system to help you stay safe when parked. Convenient motion sensors auto-wake the display and the built-in microphone transmits audio for parking guidance or added security

## **Important**

This catalog is for the buyer's use only.  
All divisions belong to Termosa Mobile Systems.

Reprinting the catalogue, copying or drawing even partial figures, and copying the design of the catalogue, is prohibited.

The technical descriptions, dimensions and drawings in this catalog are not binding.

No responsibility can be accepted for errors that may occur in printing.

All deliveries are made according to Termosa Mobile Systems' sales conditions.

Termosa Mobile Systems Inc. has the right to postpone delivery in special cases for products containing permanent stock.

JANUARY 2024

Copyrights belong to Termosa Mobile Systems Inc.

All rights are reserved.

Printed in Turkey.





**TERMOsa MOBİL SİSTEMLERİ A.Ş.**  
Hadımköy Mah. Alperay Sok. No: 7  
Arnavutköy / İstanbul  
Tel: +90 212 485 33 43  
[www.termosa.com](http://www.termosa.com)

 termosaa  termosamobil  termosamobil  termosamobil